



Cerberus® DF1191, DF1192, DF1192 (ULC), DF1101-Ex, DF1101-Ex (ULC) DF1151-Ex, Infrared flame detectors

Technical description
Planning
Installation
Commissioning

Data and design subject to change without notice. / Supply subject to availability.

© Copyright by
Siemens Building Technologies AG

Wir behalten uns alle Rechte an diesem Dokument und an dem in ihm dargestellten Gegenstand vor. Der Empfänger anerkennt diese Rechte und wird dieses Dokument nicht ohne unsere vorgängige schriftliche Ermächtigung ganz oder teilweise Dritten zugänglich machen oder ausserhalb des Zweckes verwenden, zu dem es ihm übergeben worden ist.

We reserve all rights in this document and in the subject thereof. By acceptance of the document the recipient acknowledges these rights and undertakes not to publish the document nor the subject thereof in full or in part, nor to make them available to any third party without our prior express written authorization, nor to use it for any purpose other than for which it was delivered to him.

Nous nous réservons tous les droits sur ce document, ainsi que sur l'objet y figurant. La partie recevant ce document reconnaît ces droits et elle s'engage à ne pas le rendre accessible à des tiers, même partiellement, sans notre autorisation écrite préalable et à ne pas l'employer à des fins autres que celles pour lesquelles il lui a été remis.

Ci riserviamo ogni diritto relativo al presente documento e sull'oggetto illustrato in esso. La parte che riceve il documento si impegna a non renderlo accessibile a terzi, né per intero né in parte, senza la nostra previa autorizzazione scritta ed a non usarlo per altri scopi di quello per il quale è stato rilasciato.

1	Brief overview	1
1.1	Main features	1
1.2	Design	2
1.3	Accessories	2
1.4	Application	2
1.5	Typical application examples	3
2	Technical data	4
2.1	Technical data DF1191 / DF1192 / * DF1192 (ULC)	4
2.2	Technical data DF1101-Ex / DF1151-Ex / DF1101-Ex (ULC)	5
3	Operating principle	6
3.1	Filter characteristic of the detector	7
3.2	Spectra of flames and interference sources	7
3.3	Infrared radiation of hot bodies	8
3.4	Directional sensitivity	8
4	Signal processing	9
4.1	Signal processing diagram	9
4.2	Signal / communication processor / DS11-ASIC	10
4.3	Explanatory notes	10
5	Emergency operation	11
5.1	Interactive system	11
5.2	AnalogPLUS system	11
5.3	Collective system	11
6	Line disconnection function	11
6.1	Interactive / AnalogPLUS system	11
6.2	Collective system	11
7	Diagnosis	12
7.1	Interactive system	12
7.2	AnalogPLUS system	12
7.3	Collective system	12
8	Setting functions	13
9	Planning guidelines	14
9.1	Basic information	14
9.2	Arrangement of flame detectors	15
9.3	Room monitoring with inclined detector arrangement	17
9.4	Accessories	26
9.5	Locations, ambient influences	27
10	Installation	28
10.1	Mounting	28
10.2	Connection	28
11	Commissioning	29
11.1	Conditions	29
11.2	Detector settings	29
11.3	Setting of the dip-switches	29
11.4	Connection of the detector	30
11.5	Performance check	30
12	Maintenance	31
12.1	Performance check	31
12.2	Cleaning	31

1 Brief overview

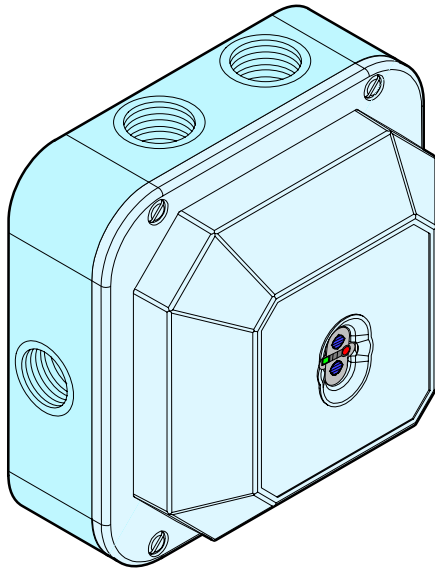

1.1 Main features

- WaveRex DF1192 triple-sensor infrared flame detector
- Two sensors for detection in various wavelengths (4...4.8 μm and 5.1...6 μm)
- Third sensor for increased resistance to sunlight (0.7...1.1 μm)
- Microprocessor-controlled signal evaluation
- Selective evaluation of flicker frequency
- Excellent immunity to false alarms due to specially developed fuzzy algorithms and the latest wavelet diagnosis
- Selectable application algorithms
- Extremely high resistance to:
 - electromagnetic influence
 - sunlight and heat radiation
 - humidity and corrosion
- Directly connectable to Cerberus interactive, AnalogPLUS and collective fire detection systems
- Can also be connected to non-Cerberus collective control units by hardware programming
- Intrinsically safe Ex Applications with collective WaveRex DF1101-Ex or interactive WaveRex DF1151-Ex
- DF1191 Flame detector as favourably-priced option with only one sensor
- Two-wire installation
- Two different sensitivity and integration stages
- Large angle of vision (min. 90°)
- High IP protection category (IP 67)
- Large operating temperature range (–35°C... +70°C)

1.2 Design

The DF11xx family of infrared flame detectors comprises:

- The DF1192 WaveRex with three infrared sensors and the specially developed evaluating algorithms for the highest application requirements, directly connectable to Cerberus interactive, AnalogPLUS and collective fire detection systems
- or the DF1101-Ex and DF1151-Ex WaveRex with the same evaluating algorithms as the DF1192 for explosion-hazard areas for the collective and interactive fire detection system
- or the DF1191 flame detector with one infrared sensor and without evaluating algorithms for simple applications, directly connectable to Cerberus interactive, AnalogPLUS and collective fire detection systems
- the DFB1190 base with the necessary cable entries and terminals

The DFB1190 base is required for installation and contains 6 PG16 threaded cable entry possibilities.

The corresponding flame detector is mounted in the base shortly before commissioning.

The flame detector is connected by being plugged into the base

All flame detectors consist of an two-component enamelled, aluminium cast housing which guarantees the required shielding against electromagnetic influence

The base consists of a robust fibre glass reinforced plastic housing which ensures the required isolated installation of the detector

1.3 Accessories

- Mounting bracket MV1 to fix the flame detector at the correct angle
- Mounting bracket MWV1 to align the flame detector with the object to be monitored
- Rain hood DFZ1190 to protect the detector in outdoor applications
- Test lamp LE3 to make a performance check on the flame detector at a distance of up to 10m
- Test lamp "Stabex" to make a performance check on the flame detector in explosion-hazard areas

1.4 Application

1.4.1 Carbonaceous (organic) materials

Infrared flame detectors are suitable for the detection of smokeless combustible liquid and gas fires as well as smoke-forming open fire involving carbonaceous materials as contained in wood, plastics, gases, oil products etc.

1.4.2 Inorganic materials

Infrared flame detectors cannot detect fires involving inorganic materials such as hydrogen, phosphorous, natrium, magnesium, sulphur etc.

However, if such materials are burned in combination with organic materials, e.g. packing material, detection is again possible.

1.5 Typical application examples

1.5.1 DF1191

- Simple warehouses
- Additionally to smoke detectors
- Can only be used where there are no sources of interference such as sun, halogen light, black body radiation etc.

1.5.2 DF1192

- Large industrial warehouses
- Hangars for military and civil aircraft
- Arc welding industry
- Power plants
- Transformer stations
- Printing works
- Motor test beds
- Atria, Malls
- Wood stores
- Underground tunnels
- Ferries and cargo boats
- Ships engine rooms

1.5.3 DF1101-Ex / DF1151-Ex

- Chemicals production plants
- Chemicals stores
- Oil refineries
- Petrol storage and pump stations
- Battery rooms

2 Technical data

2.1 Technical data DF1191 / DF1192 / * DF1192 (ULC)

Parameters	Unit	collective (k)			AnalogPLUS (a)			interactive (i)			Comments
		min.	typ.	max.	min.	typ.	max.	min.	typ.	max.	
Operating voltage quiescent condition	V	16	–	28	16	–	28	21.2	–	33.3	a + i modulated
Max. permissible voltage	V	–	–	30	–	–	28	–	–	33.3	
Operating current quiescent condition	mA	–	0.5	–	–	0.7	–	–	0.7	–	
Baud rate	kBd	–	–	–	–	0.167	–	–	4.8	–	only a + i
Switch-on current	mA	–	–	0.7	–	–	–	–	–	–	only k
Alarm voltage 1...15mA	V	5	–	11	–	–	–	–	–	–	only k
Reset voltage	V	2	–	5	–	–	–	–	–	–	only k
Reset current	µA	5	–	500	–	–	–	–	–	–	only k
Reset time U ≤2V	s	2	–	–	–	–	–	–	–	–	only k
Response indicator Voltage	V	3	–	6	–	6	–	–	6	–	* 60mA continuous, 100mA pulsed
Current	mA	–	–	60/100*	–	15	–	–	15	–	
Flashing interval time bright / dark	s	–	0.5/0.5	–	–	0.03/1	–	–	0.02/1.5	–	
Electromagnetic compatibility	V/m V/m	–	50 30	–	–	50 30	–	–	50 30	–	1MHz....1GHz 1GHz....2GHz
Viewing angle		90°			90°			90°			
Operating temperature DF1192 DF1191	°C	–35°C –25°C	–	+70°C +70°C	–35°C –25°C	–	+70°C +70°C	–35°C –25°C	–	+70°C +70°C	
Storage temperature	°C	–40°C	–	+75°C	–40°C	–	+75°C	–40°C	–	+75°C	
Humidity DF1192 DF1191	%rel. %rel.	–	–	≤100 ≤95	–	–	≤100 ≤95	–	–	≤100 ≤95	No heavy condensation of window
Colour	~RAL9010	–	x	–	–	x	–	–	x	–	pure white
Load factor	KMK APMK IMK	–	–	6	–	–	5	–	–	3	
Detection distance with 0° viewing angle standard increased	m m	–	–	27 46	–	–	27 46	–	–	27 46	0.11m ² pan n-Heptane combustible max. 15sec. response time
Start-up time after switch-on	s	–	40	–	–	40	–	–	40	–	

Standards:

pr.EN54-10
CE conformity marking

* Approval:

DF1192 (ULC), only collective
ULC Nr. CE77, Vol. 3

Classification:

Detector sensitivity "standard" Class 2
Detector sensitivity "increased" Class 1
Protection category EN60529/IEC529: DF1192 IP67
DF1191 IP44
Application category IEC721 DF1192 6K5
DF1191 3K6

Compatibility:

Compatible with all Cerberus low voltage control units with collective, AnalogPLUS and interactive signal evaluation

2.2 Technical data DF1101-Ex / DF1151-Ex / DF1101-Ex (ULC)

Parameter	Unit	collective (k)			interactive (i)			Comments
		min.	typ.	max.	min.	typ.	max.	
Operating voltage quiescent condition	V	16	–	28	18.5	–	28	i modulated
Operating current quiescent condition	mA	–	0.5	–	–	0.7	–	
Baud rate	kBd	–	–	–	–	4,8	–	Baudrate only i
Switch-on current	mA	–	–	0.7	–	–	–	only k
Alarm voltage 1...15mA	V	5	–	11	–	–	–	only k
Reset voltage	V	2	–	5	–	–	–	only k
Reset current	µA	5	–	500	–	–	–	only k
Reset time $U \leq 2V$	s	2	–	–	–	–	–	only k
Response indicator Voltage	V	1.5	–	6	–	3	–	
Current	mA	–	–	50	–	8	–	
Flashing interval bright / dark	s	–	0.5/0.5	–	–	0.02/1.5	–	
Capacitance for detection line	nF	–	–	5	–	–	5	
for indicator line	nF	–	–	15	–	–	15	
Inductance for detection line	µH	–	–	10	–	–	10	
for indicator line	mH	–	–	1,5	–	–	1,5	
Electromagnetic compatibility	V/m V/m	50 30	– –	– –	50 30	– –	– –	1MHz....1GHz 1GHz....2GHz
Viewing angle		90°			90°			
Operating temperature	°C	–35°C	–	+70°C	–35°C	–	+70°C	
Storage temperature	°C	–40°C	–	+75°C	–40°C	–	+75°C	
Humidity	%rel.	–	–	≤100	–	–	≤100	No heavy condensation of window
Colour	~RAL9010	–	x	–	–	x	–	pure white
Load factor	KMK IMK	–	–	6	–	–	3	
Line factor	KLK ILK	–	–	25	–	–	32	k = DC1192 i = E3M171
Detection distance with 0° viewing angle standard	m	–	–	27	–	–	27	0.11m ² pan
increased	m	–	–	46	–	–	46	n-Heptane combustible max. 15sec. response time
start-up time after switch-on	s	–	40	–	–	40	–	

Standards:

pr.EN54-10
CE conformity marking
EN50014/EN50020 for explosion-hazard areas

Classification:

Detector sensitivity "standard" Class 2
Detector sensitivity "increased" Class 1
Protection category EN60529/IEC529: IP67
Application category IEC721 6K5
Ex classification EEx ib IIC T4

Compatibility

Compatible with all Cerberus low voltage control units with collective signal evaluation, together with detection line coupler and shunt Zener diode barrier and with interactive signal evaluation together with shunt Zener diode barrier

Ex approval DF1101-Ex:

PTB Nr. Ex-98.E.2158

Ex approval DF1151-Ex:

PTB Nr. Ex-99.E.2156

Ex approval DF1101-Ex (ULC):

ULC Nr. CE77, Vol. 2

Intrinsic safety:

Intrinsic safety «i» when using a certified shunt Zener diode barrier with the following data:

$$\begin{aligned} R_i &\geq 280\Omega \\ U_i &\leq 28V \\ I_i &\leq 100mA \\ P_i &\leq 700mW \end{aligned}$$

3 Operating principle

The detection elements of the DF1192 infrared flame detector consist of two pyroelectrical sensors and a silicon photodiode.

The DF1191 infrared flame detector contains only sensor A.

- **Sensor A:** The pyroelectrical sensor A reacts to infrared flame gas in the characteristic CO₂ spectral range between 4.0...4.8µm
- **Sensor B:** The pyroelectrical sensor B measures the infrared radiation from sources of interference in the range between 5.1...6µm.
- **Sensor C:** The silicon photodiode measures the sunlight in the range between 0.7...1.1 µm.

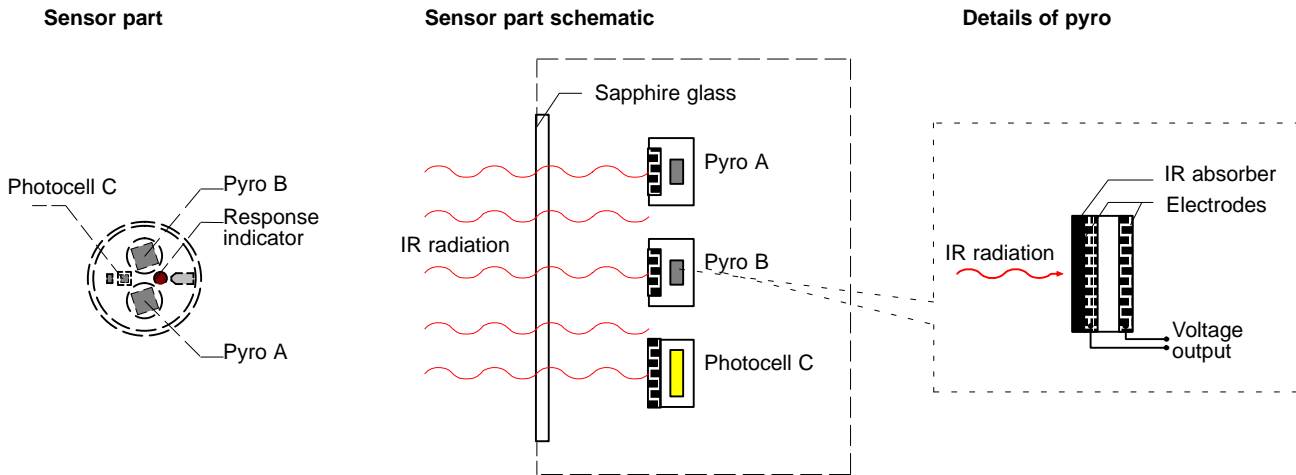

Fig. 1 Detector sensors

3.1 Filter characteristic of the detector

Transmission [%] , relative spectral sensitivity [S rel]

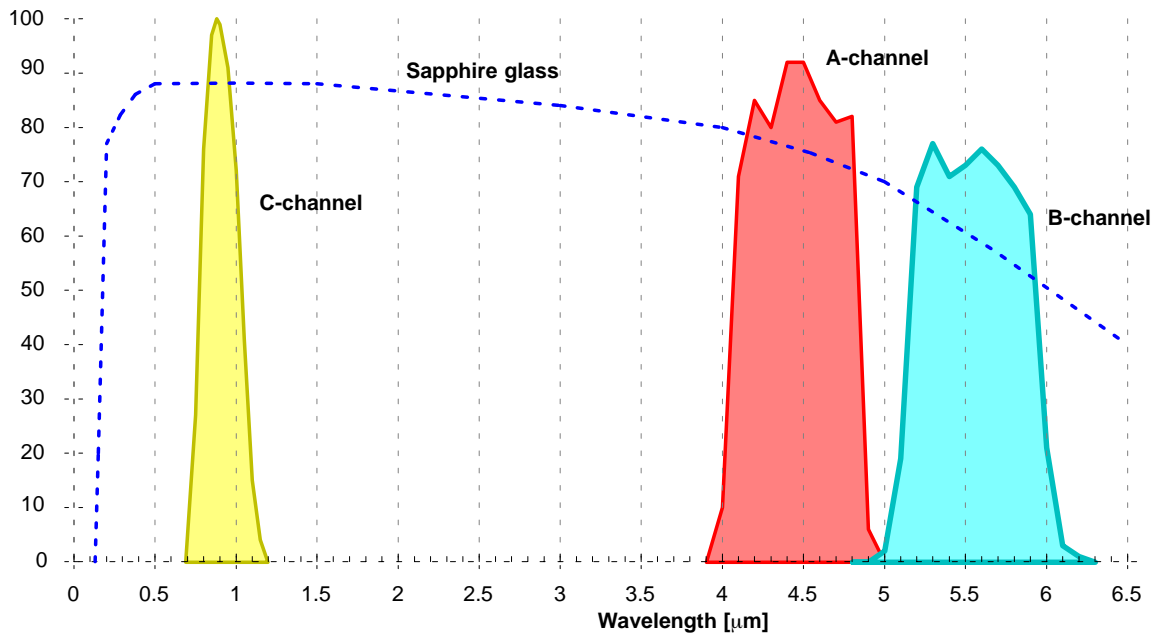

Fig. 2 Filter characteristic of the sapphire glass

3.2 Spectra of flames and interference sources

Relative spectral sensitivity [S rel]

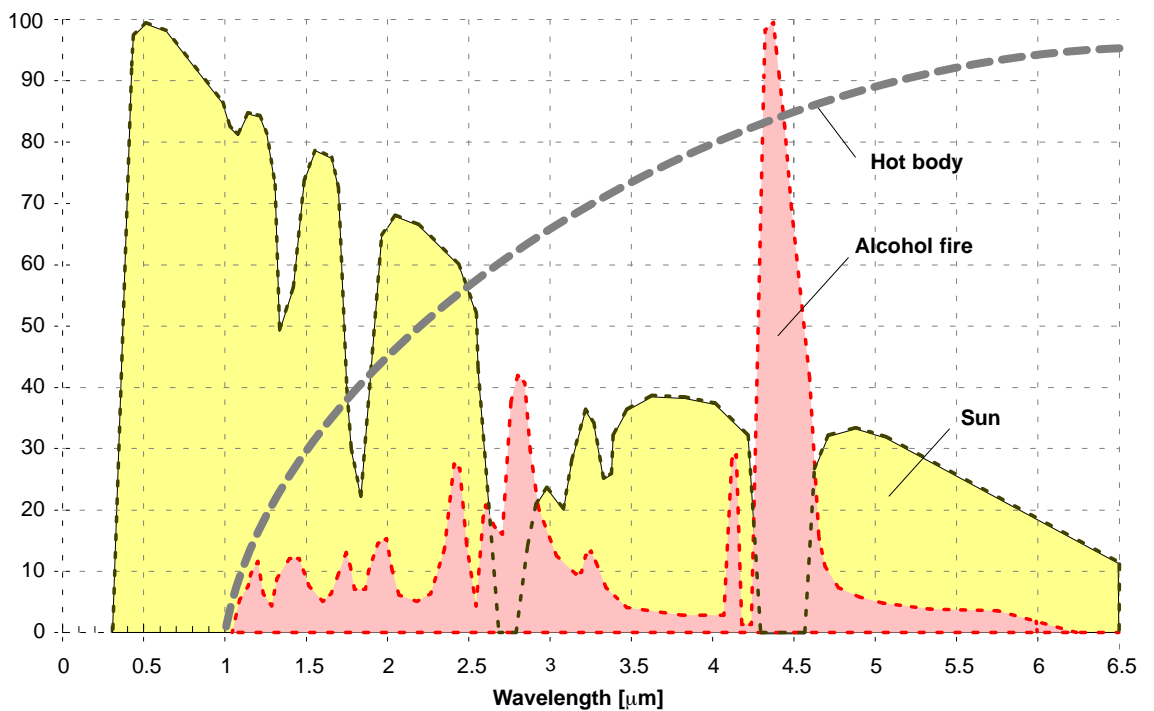

Fig. 3 Spectra of flames and interference sources

3.3 Infrared radiation of hot bodies

- Each body emits infrared radiation and the hotter it is, the more radiation emitted.
- The sun emits a uniform spectrum which is equivalent to a hot body of 6000K.

As is shown in the previous graph, the sun emits a relatively low signal in the detection range of the IR flame detector which is advantageous for detection.

3.4 Directional sensitivity

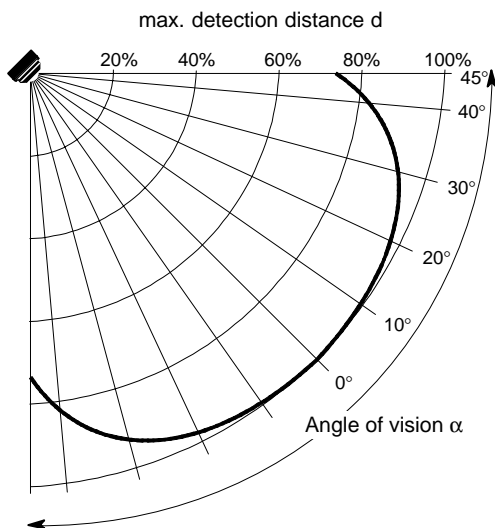

Fig. 4 Max. detection distance as a function of the angle of impingement of the flame radiation at constant fire size (0° = detector axis)

4 Signal processing

4.1 Signal processing diagram

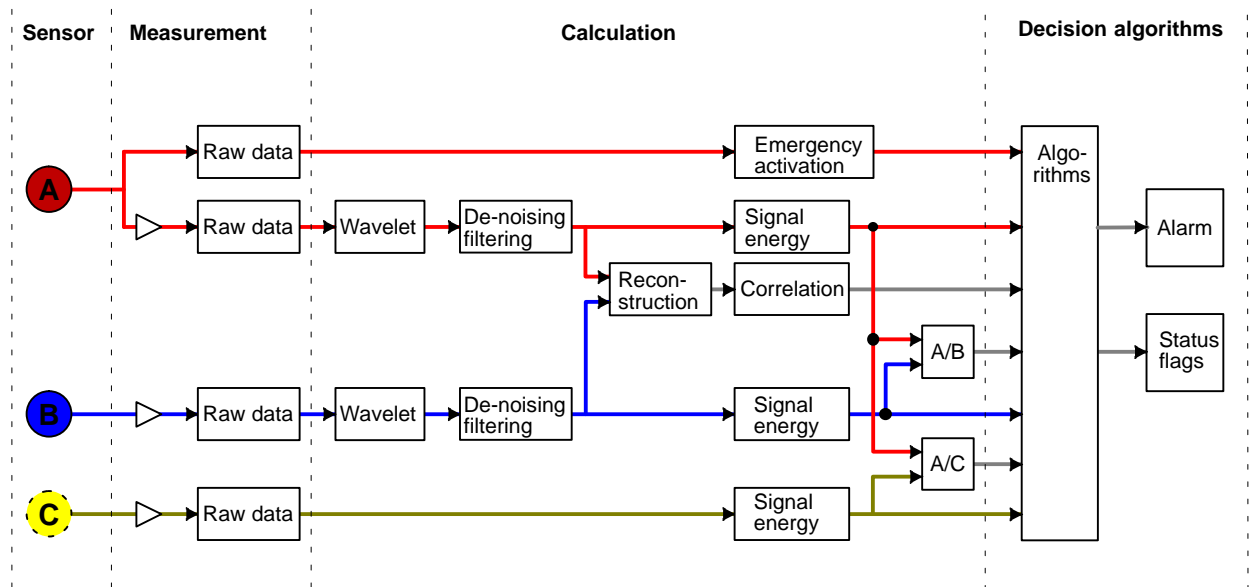

Fig. 5 Signal processing diagram

4.1.1 Sensor

- At the beginning of signal processing three sensor signals from pyrosensors A and B as well as the photocell C are fed to the measurement stage.

4.1.2 Measurement

- After several amplifications, sensor signals A, B, C are measured simultaneously, whereby the raw data are passed on for calculation.

4.1.3 Calculation

- Depending on the measuring channel, Wavelet, de-noising, reconstruction, signal energy, correlation and/or ratio A/B or A/C are calculated and fed to the algorithms.

4.1.4 Decision algorithms

- The results are analysed in the decision algorithms and issued as an alarm or status messages.

4.2 Signal / communication processor / DS11-ASIC

The entire signal processing is carried out in the signal processor. This prepares the sensor input signals in such a way that danger levels and functional statuses of DS11-ASIC and of the communication processor are suitable for the control unit.

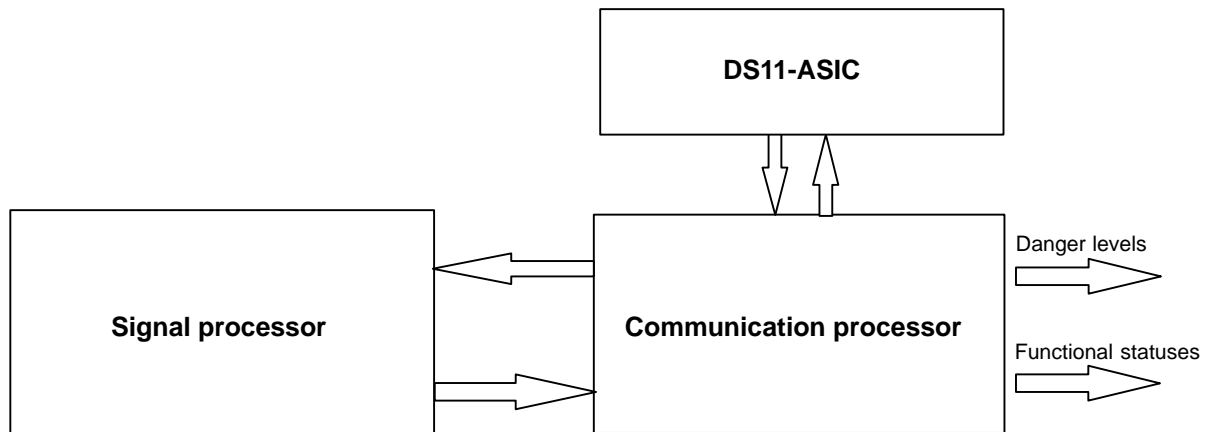

Fig. 6 Signal processing / communication processor / DS11-ASIC

4.3 Explanatory notes

4.3.1 Wavelet

- The Wavelet transformation is used to work out the frequency components of channels A and B. That is, the flicker spectrum of a flame is broken up into various levels. Each level indicates the importance of the frequency within a frequency band of 0...16 Hz.

4.3.2 De-noising

- After a Wavelet analysis, the signal energy at all levels which are below a certain threshold are reset at zero.
- In the same way, the DC part and/or selected frequency bands can be removed from a signal.

4.3.3 Reconstruction

- Following the Wavelet analysis and de-noising, the signal is reconstructed.

4.3.4 Correlation

- The correlation of channels A and B is calculated and fed to the decision algorithms.

4.3.5 Signal energy

- The signal energy ratios between channels A/B or channels A/C are calculated.

4.3.6 Decision algorithms

- On the basis of the correlation and the signal energy ratio, the alarm threshold is adapted accordingly in the decision algorithm.

5 Emergency operation

5.1 Interactive system

If the main processor line card malfunctions, or if the DF11xx is for any reason no longer regularly polled, then the DF11xx switches automatically to emergency operation and thus can still activate a collective alarm in the event of fire.

5.2 AnalogPLUS system

The AnalogPLUS system has no emergency operation function.

5.3 Collective system

Emergency operation is unnecessary.

6 Line disconnection function

The DF119x is equipped with a line disconnection function, i.e. it has electronic switches (FET) on both sides of the line connections which open upon line short circuit.

6.1 Interactive / AnalogPLUS system

If a short circuit occurs on the detector bus, the disconnecter FET ensures that not the entire bus line malfunctions, rather only the defective section of the line is isolated.

6.2 Collective system

If a fault is signalled, the detector opens its disconnecter FET to isolate the line termination element and to signal the fault to the control unit. This cuts off the voltage to all subsequent detectors.

7 Diagnosis

The DF11xx flame detectors transmit the following events to the control unit:

7.1 Interactive system

- Danger level 0 (quiescent value)
- Danger level 3 (danger very probable)
- Functional status "Impairment"
- Functional status "Fault"

7.2 AnalogPLUS system

- Danger level "Normal" (quiescent value)
- Danger level "Alarm" (danger very probable)
- Functional status "Fault"

7.3 Collective system

- Danger level "Alarm"
- Functional status "Fault"

The danger level 3 or "Alarm" serve as alarm transmission to the control unit.

Depending on the importance, the functional statuses signal impairment or fault in the μ P evaluation or in the communication with the control unit.

8 Setting functions

Function	DIP-Switches										Explanation
	S1	S2	S3	S4	S5	S6	S7	S8	S9	S10	
Standard (collective)	<input type="checkbox"/>	<input type="checkbox"/>	<input type="checkbox"/>	<input type="checkbox"/>	<input type="checkbox"/>	<input type="checkbox"/>	<input type="checkbox"/>	<input type="checkbox"/>	<input type="checkbox"/>	<input type="checkbox"/>	Standard sensitivity (set at factory)
Collective	<input type="checkbox"/>	<input type="checkbox"/>									Collective fire detection system
AnalogPLUS	<input type="checkbox"/>	<input type="checkbox"/>									AnalogPLUS fire detection system
Interactive	<input type="checkbox"/>	<input type="checkbox"/>									Interactive fire detection system
Sensitivity			<input type="checkbox"/>								Standard
			<input type="checkbox"/>								Increased
Signal processing time				<input type="checkbox"/>							Standard
				<input type="checkbox"/>							Extended
Sunlight filter ¹⁾					<input type="checkbox"/>						Normal resistance to sunlight
					<input type="checkbox"/>						Resistance to sunlight increased
Frequency filter						<input type="checkbox"/>					Standard filtering
						<input type="checkbox"/>					Special filtering of higher sensor frequencies
Special application ¹⁾			<input type="checkbox"/>		<input type="checkbox"/>				<input type="checkbox"/>		Special application (motor test bed)

Fig. 7 Table of setting functions

1) Not active with DF1191

9 Planning guidelines

9.1 Basic information

- The standard pr.EN54-10 forms the base for this planning guideline

9.1.1 Standard fire

pr.EN54-10 specifies 2 standard fires:

- Bowl 33x33cm (0.1m²) n-heptan with 3% toluol
- Bowl 50x50cm (0.25m²) ethylalcohol

9.1.2 Classification

pr.EN54-10 specifies 3 detector classes, in which alarm must be guaranteed for both standard fires at an angle of vision of 0°

- Class 1: Detectors must alarm from 0m to at least 25m
- Class 2: Detectors must alarm from 0m to at least 17m
- Class 3: Detectors must alarm from 0m to at least 12m

9.2 Arrangement of flame detectors

9.2.1 Direct and indirect radiation

The flame radiation from possible sources of fire must reach the detector. As with light, this is possible through

- direct line-of-sight radiation

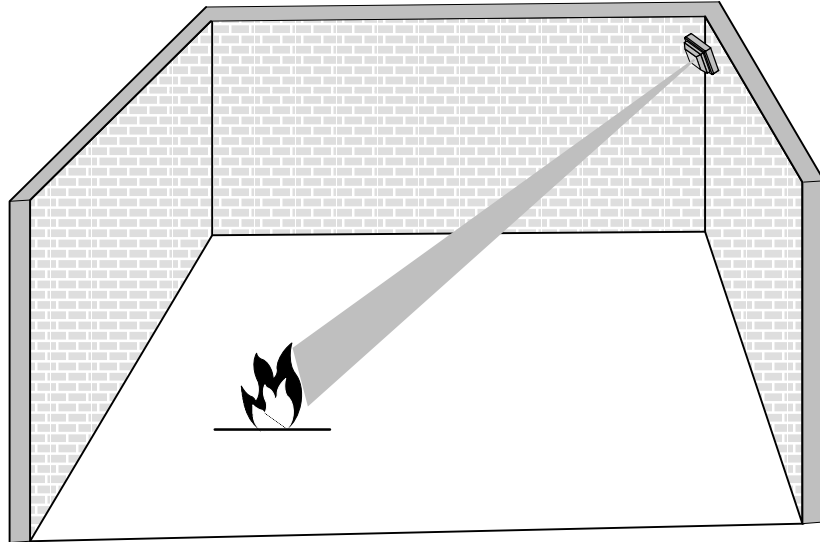

Fig. 8 Direct radiation

- indirect radiation by reflection on walls, fixtures and fittings etc.

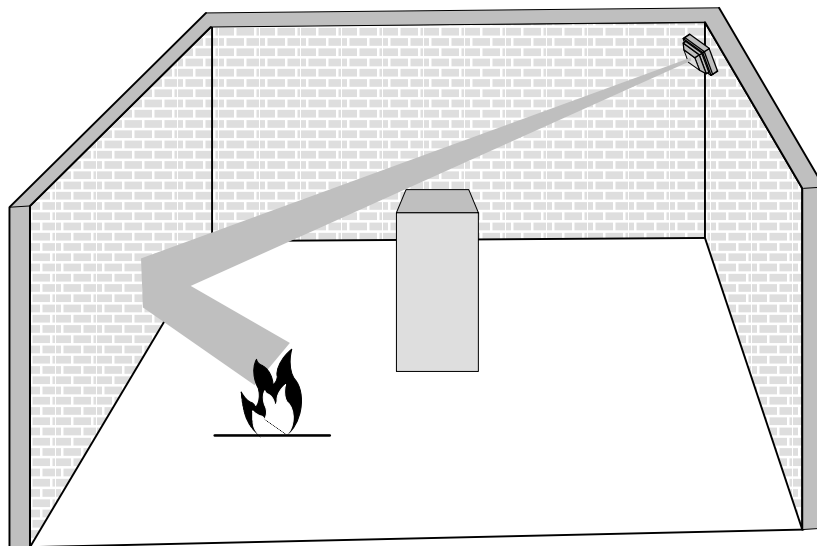

Fig. 9 Indirect radiation through reflection

Direct radiation is **many times** stronger than indirect radiation. Therefore, the detector should always have direct line-of-sight to all possible sources of fire within the area monitored.

9.2.2 Surveillance area

The surveillance area of a detector depends on the following factors:

- detection distance
- the minimum size of fire to be detected
- combustible
- detector sensitivity
- detector arrangement

9.2.3 Maximum detection distances (d) at 0° angle of sight

- Infrared flame detectors WaveRex DF1192 and DF1101-Ex fulfil in the standard sensitivity class 2 and with increased sensitivity class 1
- Standard sensitivity as well as a fire size of 0.25m² ethylalcohol serve as basic value for the further calculations
- With large distances, part of the infrared flame radiation in the CO₂ spectral range is absorbed
- To ensure the excellent detection qualities, the maximum detection distance (d) must be limited to max. 100m

9.2.4 Calculation of detection distance d

$$d = \text{Basic distance} \times \sqrt{\frac{\text{desired size of fire}}{\text{basic size of fire}}}$$

Example:

$$d = 23\text{m} \times \sqrt{\frac{1\text{m}^2}{0.25\text{m}^2}} = 46\text{m}$$

9.3 Room monitoring with inclined detector arrangement

9.3.1 Angle of inclination, lateral angle

The best form of room monitoring is achieved by mounting the detector high in the corner of a room with the detector inclined towards the floor:

- Angle of inclination of detector axis 45°
- Lateral angle 45°

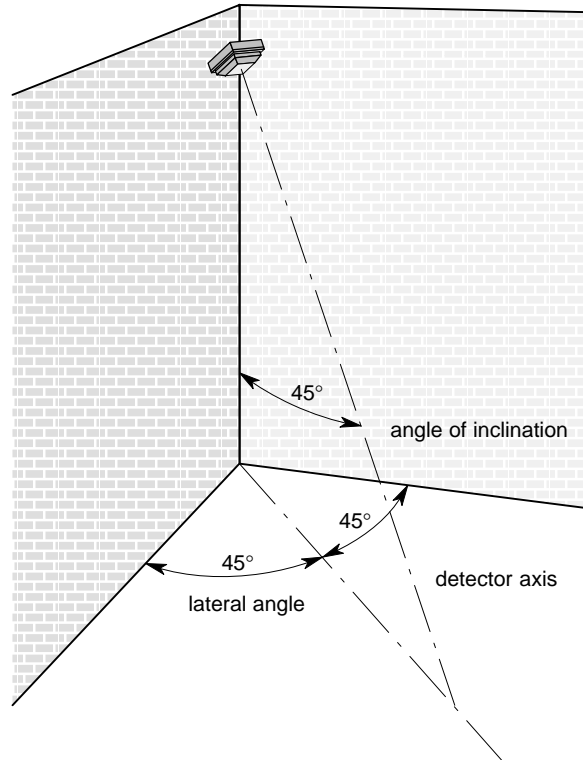

Fig. 10 Angle of inclination and lateral angle of the detector axis

9.3.2 Features of a inclined detector arrangement

- The corner of the room at floor level, as well as the walls that form the corner remain within the detector's field of vision at an angle of 90°
- Uniform response sensitivity within a defined monitoring area
- Slight obstruction of vision by smoke from the fire. For this reason the detector is mounted below the ceiling at 10% of the room height
- The space above the detector lies outside the detector's surveillance area.

9.3.3 Limiting the test fire (ethylalcohol)

To prevent the room from being damaged by the test fire, the fire must be of a size corresponding to the height of the room.

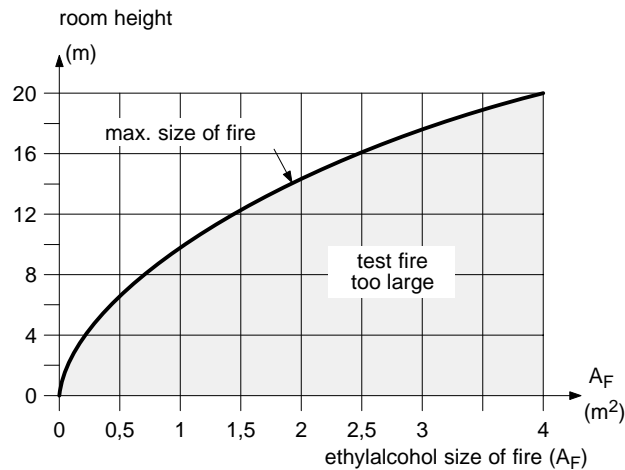

Fig. 11 Graph to show maximum permissible size of fire according to room height (curve construction: $10 \times \sqrt{A_F}$)

9.3.4 Area monitored and lateral dimension a

The detector's response sensitivity and therefore its surveillance area depend on:

1. The level of sensitivity selected at the detector
2. The size of fire A_F to be detected
3. The distance fire / detector
4. The angle at which radiation strikes the detector
5. The combustible

A room to be monitored is divided into one or more cubic units. They are monitored by a detector mounted at a 45° angle to the vertical axis. The lateral dimension a of the cubic units to be monitored depend on the above five parameters. The maximum mounting height corresponds with the lateral dimension a .

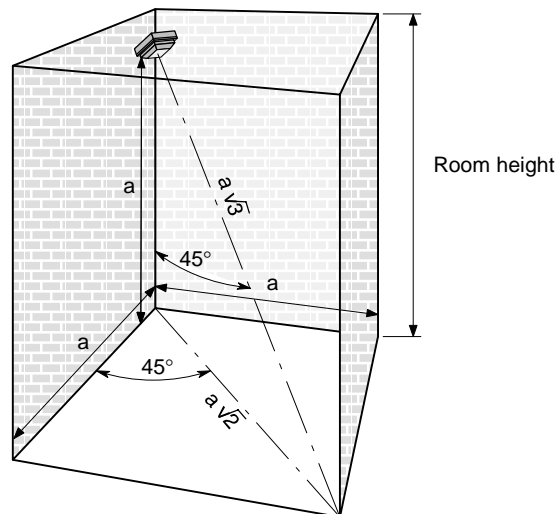

Calculation of the lateral dimension a from the detection distance d or the cube diagonal

$$a = \frac{d}{\sqrt{3}}$$

Example:

$$a = \frac{46\text{m}}{\sqrt{3}} = 26.55\text{m} \sim 27\text{m}$$

Fig. 12 Monitored cube with lateral dimensions a

9.3.5 Choice of sensitivity parameters

- Normally, installations are planned using standard sensitivity (switches 3–9 OFF)
- If deceptive phenomena are to be expected, switches 4–9 must be parameterized according to Fig. 7
- Increased sensitivity must only be chosen if absolutely no deceptive phenomena are present in the field of vision (switches 3 ON, 4–9 OFF)

9.3.6 Eliminating of deceptive phenomena

Screens (not supplied by Cerberus) must be used to shield the detector from interference radiation (e.g. burn-off pipes in the oil industry). The screens must be made of non-reflecting material.

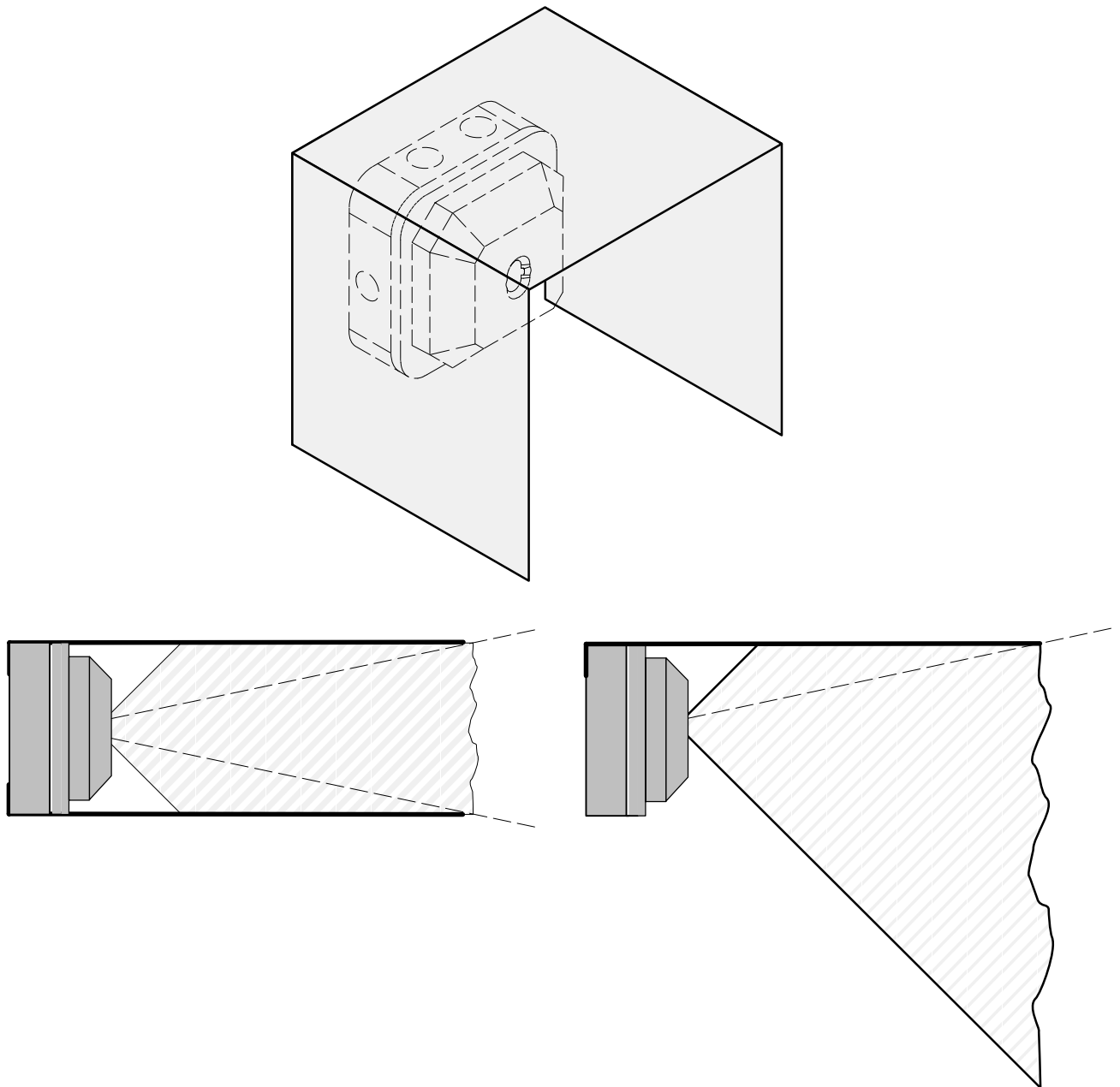

Fig. 13 Screen

9.3.7 Maximum lateral dimension in relation to size of fire (ethylalcohol)

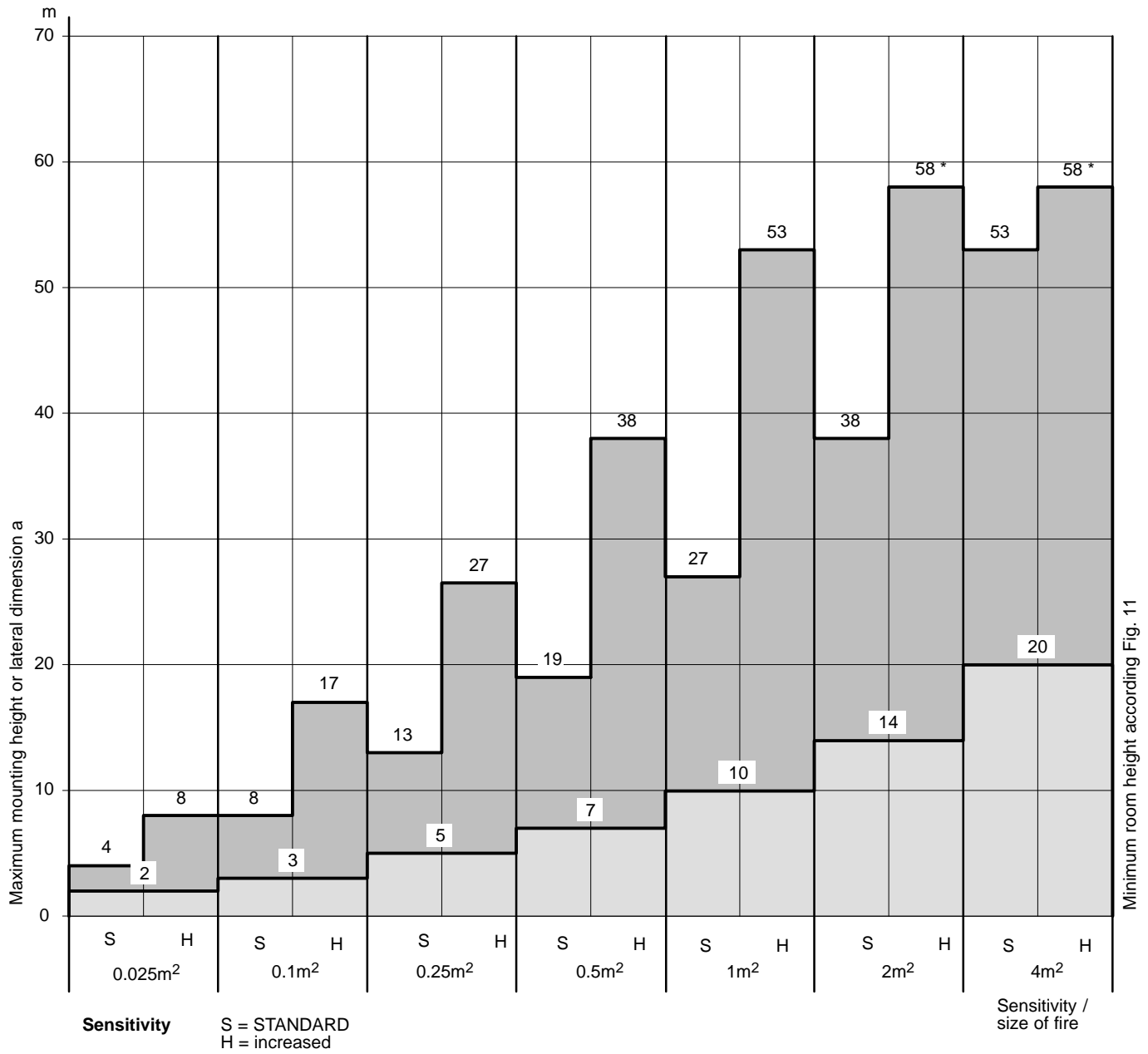

Fig. 14 Table with maximum lateral dimension **a** of the monitored square area and mounting height of detector
* Max. admissible detection distance in the lateral dimension **a**

9.3.8 Correction factors of various combustibles for the maximum lateral dimension a

Combustible	Correction factor for lateral dimension a
Ethyl alcohol puriss.	1.0
Petrol (Heptan purum)	1.5
Diesel oil (gas oil)	0.8
Kerosene (jet fuel A1)	1.0
Methyl alcohol purum	0.8
Crude oil	1.0
Acetone	1.5

Fig. 15 Correction factors of various combustibles for the maximum lateral dimension a
If, e.g. petrol is the combustible to be detected, then the lateral dimension and maximum mounting height a can be 1.5 times larger than in the table Fig. 14.

9.3.9 Application examples

Dimensions of the room to be monitored:
L: 28m, W: 20m, H: 15m

1. Calculate max. permissible size of test fire on the basis of room height (see Fig. 11 and Fig. 16).

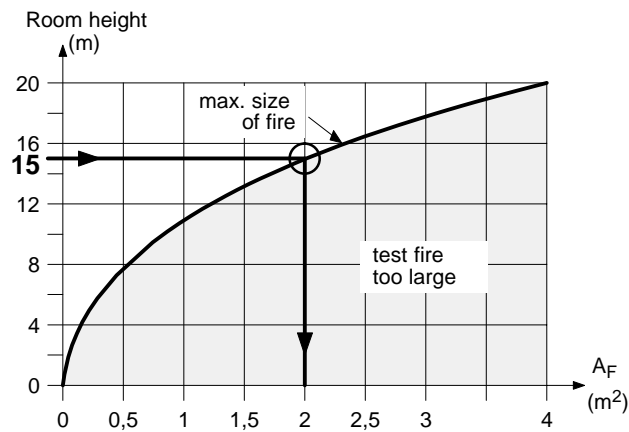

Fig. 16

Instead of the maximum permissible 2m^2 it is often useful to use a smaller fire for alarm actuation.

2. Reducing obstructed vision caused by smoke

Smoke only slightly restricts for IR detectors, nevertheless, the detectors should not be placed in the highest smoke accumulation. The detector must be mounted below the ceiling at 10% of the room height. Thus the detector is mounted at a height of 13.5m.

3. Calculating the permissible lateral dimension a

In table Fig. 14 resp. Fig. 17 draw a horizontal line at 13.5m.

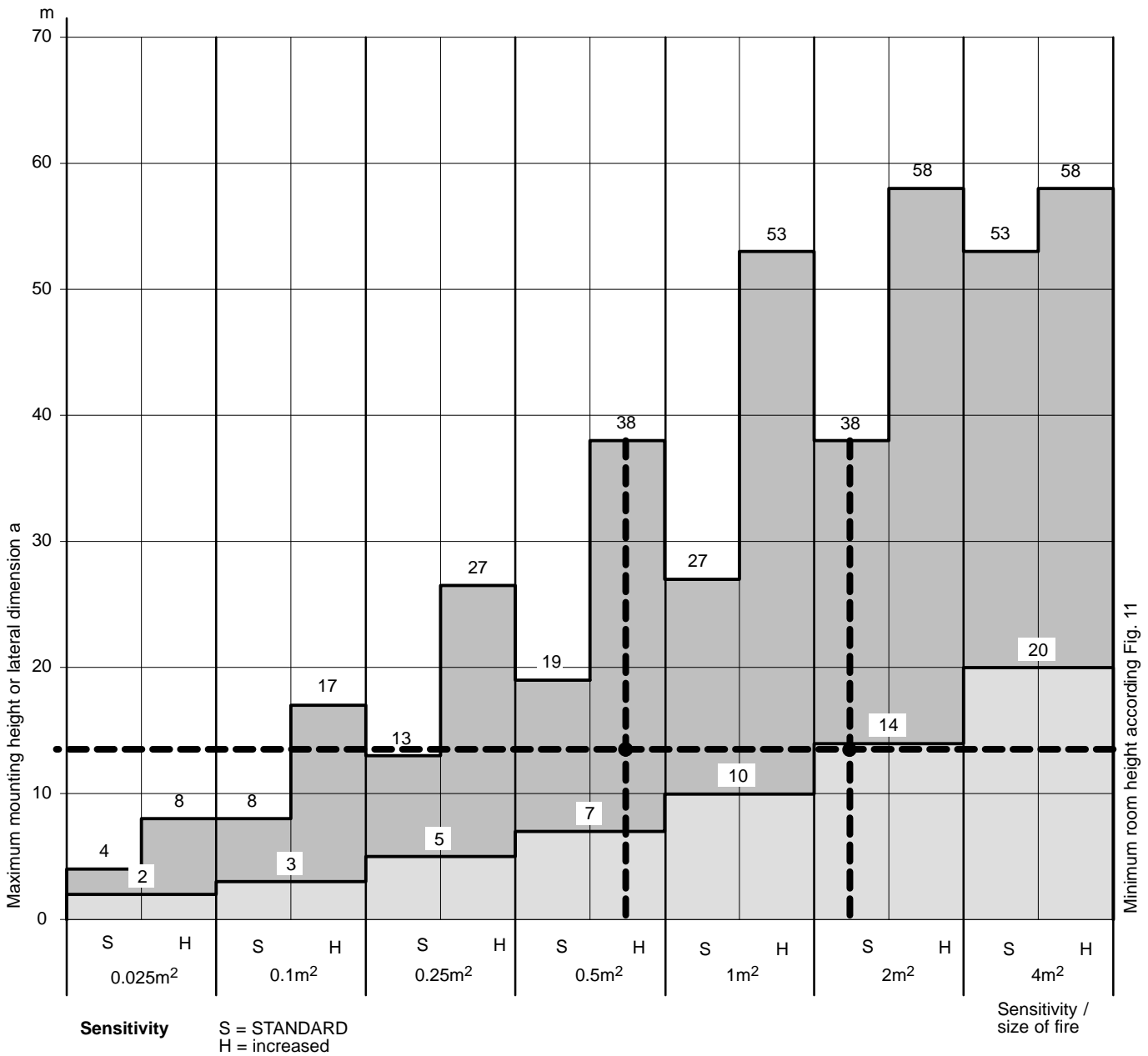

Fig. 17 Extract from table Fig. 14

All lateral dimensions which lie within the **dark area** formed by the intersection (with the exception of impermissible 4m² size fire) may be used. If the room is only monitored by 1 detector (mounted in the corner of the room), a lateral dimension of 28m is required. This first appears in the 1m² fire size column (from left to right) and sensitivity increased. If planned with standard sensitivity, 2m² fire size is required.

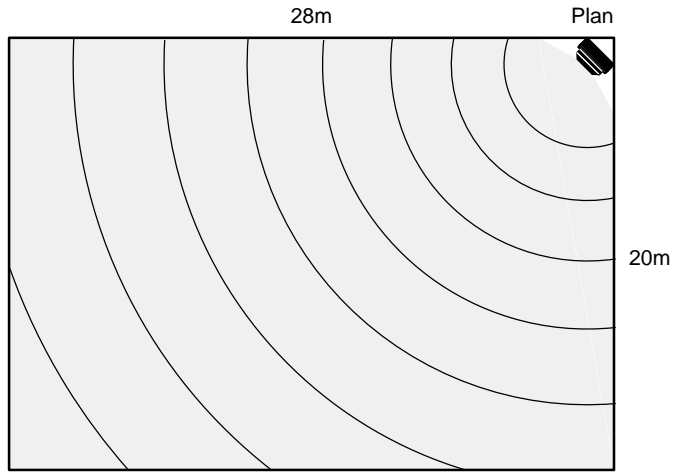

Fig. 18 Room monitoring with 1 detector, required size of fire $A_F = 2\text{m}^2$ (ethylalcohol) with standard sensitivity

The smallest possible size of fire which can be detected by a detector mounted at 13.5m, is a 0.1m^2 fire with increased sensitivity. The lateral dimension is 17m. In order that the entire area of a 28m x 20m room is monitored, a detector must be mounted in each corner.

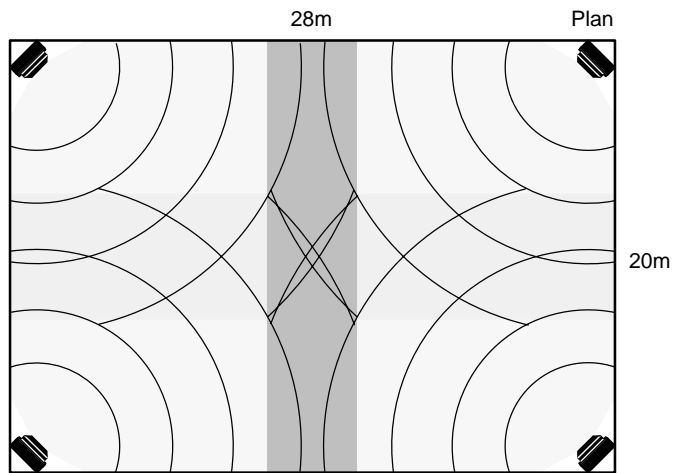

Fig. 19 Room monitoring with 4 detectors required size of fire $A_F = 0.1\text{m}^2$ (ethylalcohol) with increased sensitivity

Two detectors can also be used as a compromise solution, i.e. detectors mounted in diagonally opposite corners. A minimum lateral dimension of 20m is required. This is fulfilled with a 0.25m^2 fire size and with increased sensitivity.

When using more than one detector, ensure mutual redundancy, i.e. the detectors should have overlapping fields of vision.

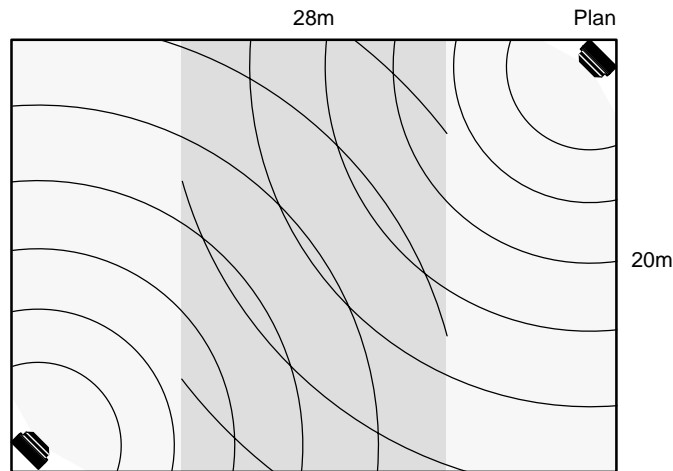

Fig. 20 Room monitoring with two detectors, required size of fire $A_F = 0.25\text{m}^2$ (ethylalcohol), with redundancy and increased sensitivity

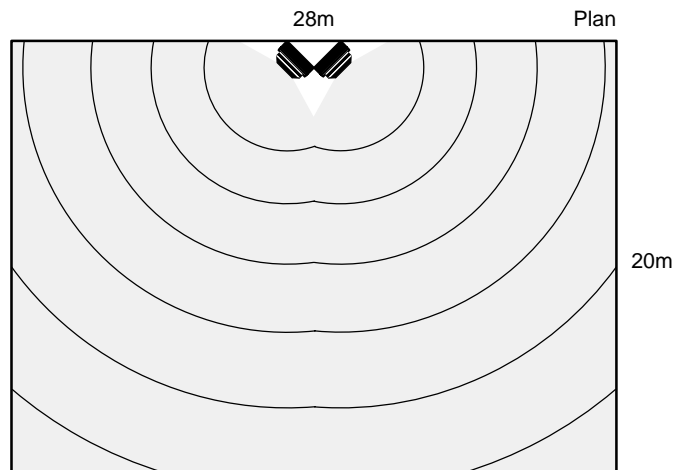

Fig. 21 Room monitoring with two detectors, minimum size of fire $A_F = 0.25\text{m}^2$ (ethylalcohol), without redundancy. **Not recommended!**

The essential requirement for all examples is that the two 45° angles be maintained as shown in Fig. 10!

9.3.10 Further application examples:

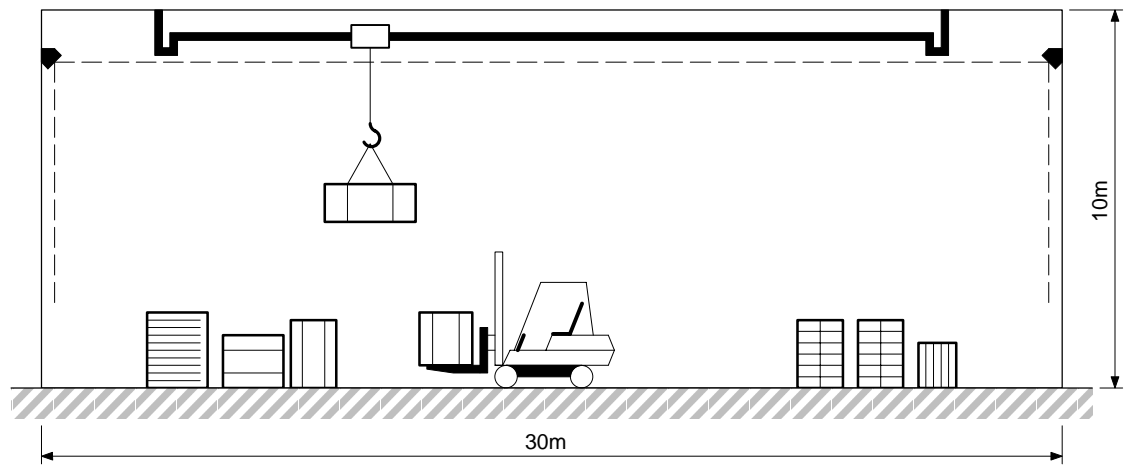

Fig. 22 Workshops, dispatch departments etc.

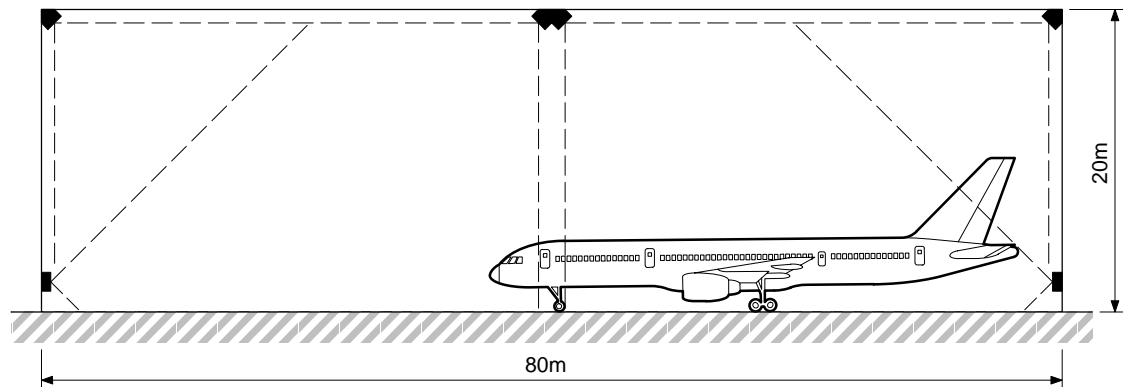

Fig. 23 Hangars, shipyards etc.

9.4 Accessories

9.4.1 Mounting bracket

For room monitoring, installation using the MV1 mounting bracket is recommended. This accessories give the detector the correct angle of inclination.

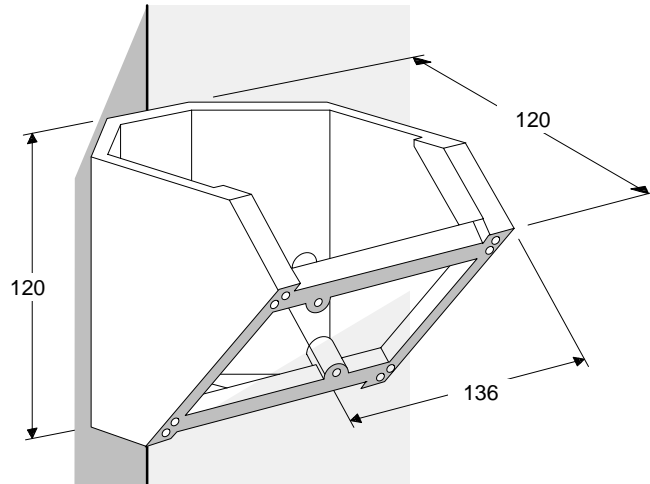

Fig. 24 Mounting bracket MV1

9.4.2 Ball and socket joint

For special arrangements (e.g. monitoring of appliances without 45° angle) installation using the MWV1 ball and socket joint is recommended. This accessory enables simple aligning of the detector in direct view at the object to be monitored.

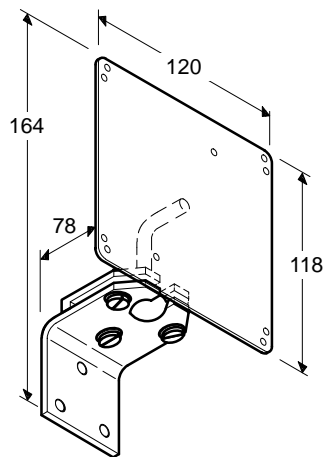

Fig. 25 MWV1 ball and socket joint

9.4.3 Rain hood

For outdoor applications use the DFZ1190 rain hood for protection of the plastic housings.

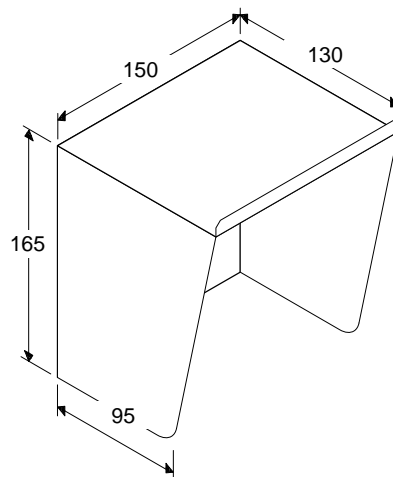

Fig. 26 Rain hood DFZ1190

9.5 Locations, ambient influences

9.5.1 Obstruction by window glazing

Detection through glass and plastic materials is strictly prohibited. Glass and plastic materials reduce the IR radiation such an extent, that correct detection is impossible.

9.5.2 Oil or water film on sensor window

Film of oil or water on the sensor windows reduces sensitivity by as much as 15% (reduction of detection distance).

9.5.3 Solar radiation

If direct or indirect solar radiation is possible, set switch 5 to ON.

With powerful halogen lamps, set switches 4 + 5 to ON. Chopped light from halogen lamps without protective glass has the effect of test lamp LE3 and can activate the detector.

10 Installation

10.1 Mounting

Mount the infrared flame detectors DF11xx on a stable, vibration-free surface.

For room monitoring, installation using the mounting bracket MV1 is recommended. This accessories give the detector the correct angle of inclination.

The MWV1 ball and socket joint is available for the alignment on a corresponding object.

Cable entries: 6 PG16 threads are provided on the base.

To comply with the required IP protection category select the correct PG16 screwed cable glands.

With humid climatic conditions, always use screwed cable glands.

10.2 Connection

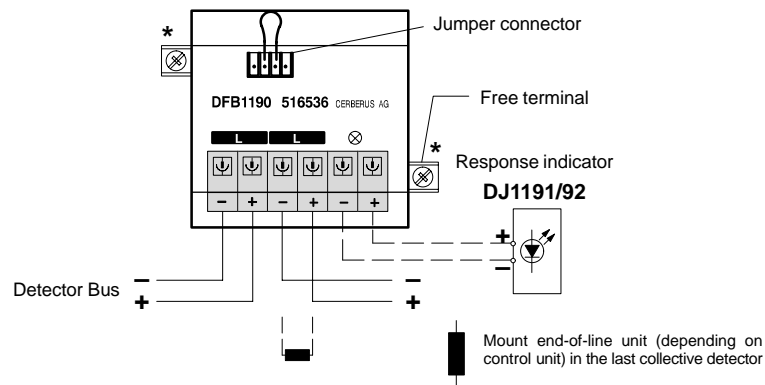

Fig. 27 Connection diagram for DF1191/DF1192

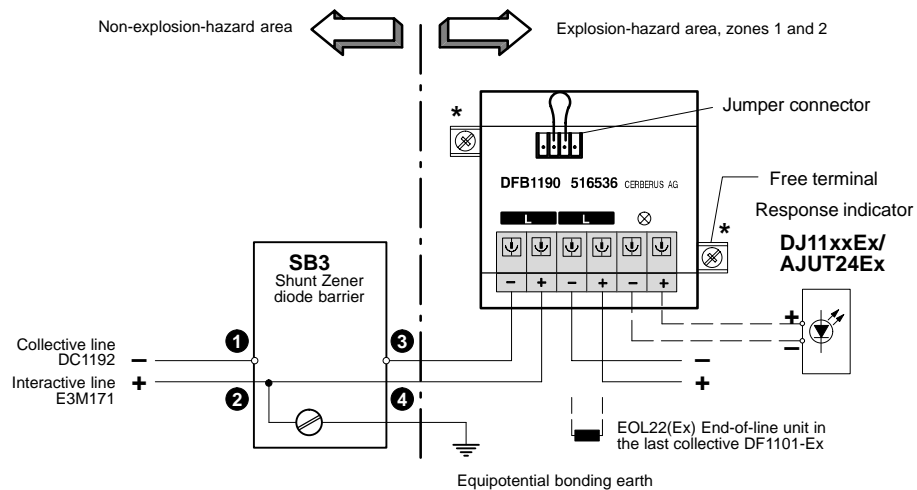

Fig. 28 Connection diagram for DF1101-Ex / DF1151-Ex

11 Commissioning

11.1 Conditions

For trouble-free commissioning, the line network must be installed and tested according to the AlgoRex planning and installation guidelines.

11.2 Detector settings

Before connecting the detector, the 10 dip switches must be programmed according to the table below.

When they leave the factory, all switches are set to "OFF", i.e. normal application in the collective system.

11.3 Setting of the dip-switches

See also table chapter 8

DIP	OFF	ON	Explanation
1 2	x x		Collective system
1 2	 x	x	System AnalogPLUS
1 2	 	x x	Interactive system
3	x		Standard sensitivity
3		x	Increased sensitivity (provided not exposed to optical interference)
4	x		Signal processing time short (standard)
4		x	Signal processing time increased (if exposed to powerful optical interference)
5	x		Normal solar radiation resistance (standard)
5		x ¹⁾	Resistance to solar radiation increased (when used outdoors or if exposed to reflected sunlight)
6	x		No filtering out of high sensor frequencies (standard)
6		x ²⁾	Filtering out of high sensor frequencies (powerful EMI, but not admissible at gas flame detection)
7			No function
8			No function
9	x		No special application (standard)
9		x ¹⁾	Special application (hot IR radiation at a short distance, e.g. motor test bed). In this case S3 must be set to ON and S5 set to OFF.
10			No function

1) Not active with DF1191

2) Gasjet flames also have high frequencies, detection only in position "OFF"

11.4 Connection of the detector

- Remove the jumper connector from the base.
- Put in the detector unit into the base.
- Mount the detector unit with the 4 screws on the base.

11.5 Performance check

- Switch control unit to TEST
- Actuate the detector **in non-explosion hazard areas** using the test lamp LE3
- Application of the test lamp see operating instruction LE3
- The detector must respond within 20 seconds (response indicator flashes)
- Actuate the detector **in explosion hazard area** using the STABEX lamp
- Hold lamp vertically approx. 5cm from detector sensor «A» and cover sensor «B»
- Modulate approximately 2Hz pulse with the button

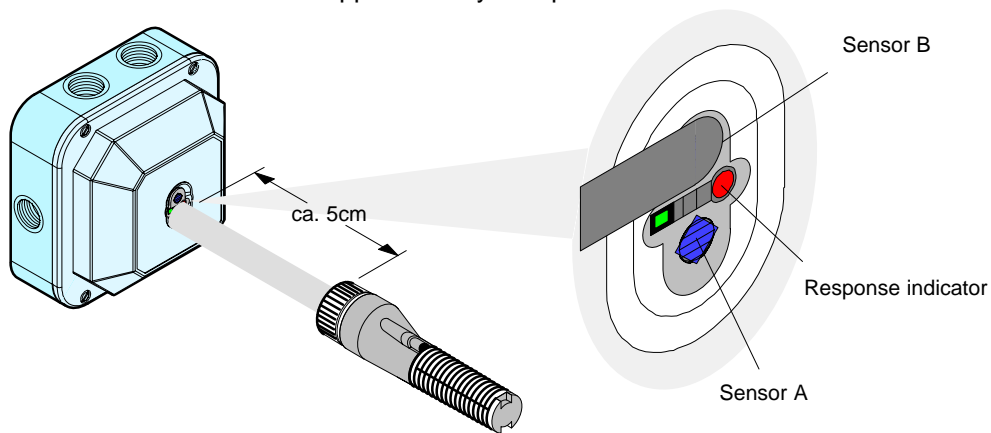

Fig. 29 Testing with STABEX lamp

- The detector must respond within 20 seconds (response indicator flashes)

12 Maintenance

12.1 Performance check

- Check the detector regularly, using test lamp LE3 or STABEX (see chapter 11.5).
- Recommendation: Once per year.
- Any detectors which do not function correctly should be replaced by the sales organization.

12.2 Cleaning

- An outside cleaning of the protective glass will be necessary, when the sensors are not visible.
- Clean the protective glass with a soft, methylated spirit moist cloth.
- Subsequently carry out a performance check.

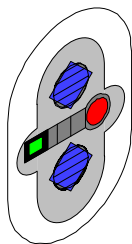
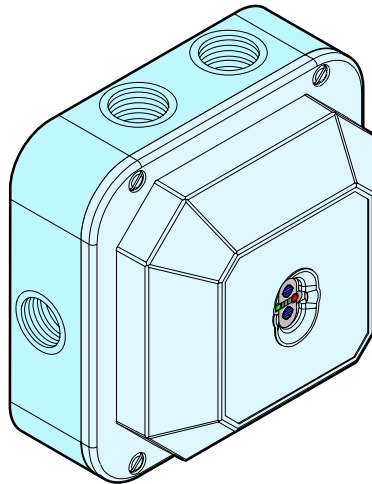

Cleaning unnecessary

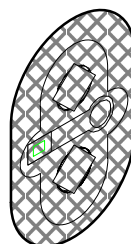

Cleaning necessary

Siemens Building Technologies AG
Alte Landstrasse 411
CH-8708 Männedorf
Tel. +41 1 - 922 61 11
Fax +41 1 - 922 64 50
www.cerberus.ch

