



Synco™ 100

Differential Temperature Controller

RLE127

Differential temperature controller for solar storage systems. Compact design with two 2-position control output AC 24...230 V.

Use

Plant types:

- Solar energy plants with storage tanks
- Swimming pool heating systems with solar panels
- Heat storage plants with several storage tanks
- Multiboiler plants

Building types:

- Residential buildings of all types
- Non-residential buildings of all types

Application example:

- Control of the temperature differential between 2 plant components or plant sections, e.g. between heat source and heat consumer

Devices that can be controlled:

- 2-position actuators, e.g. thermal actuators
- 3-position actuators
- Circulating pumps, charging pumps, boilers
- On/off actuating devices

Functions

- Main functions**
- Control of the adjusted temperature differential through 2-position control of one or several devices
 - Pre-configured application types selected by DIP switch
 - Changeover to a secondary heat source upon demand

- Other functions**
- Minimum charging temperature option
 - Absolute temperature setpoint
 - Maximum temperature limitation
 - Remote setpoint adjustment
 - Test mode as a commissioning aid

Ordering

When ordering, please give type reference **RLE127**.

Equipment combinations

- Controlled devices**
- The following types of devices can be controlled:
- 2- or 3-position actuators
 - On/off actuating devices of all types
- Controlled devices must have control contacts suited for AC 24...230 V, 2 A.

- Remote setpoint adjuster**
- Suitable remote setpoint adjuster:

<i>Type of unit</i>	<i>Type ref.</i>	<i>Data Sheet</i>
Remote setpoint adjuster	BSG21.1	N1991
Scala 0...30 K for remote setpoint adjuster	BSG-Z	N1991

- Temperature sensors**
- All types of temperature sensors using a sensing element LG-Ni 1000 Ω at 0 °C can be used for the external signal (B2 and B3). For example:

<i>Type of sensor</i>	<i>Type reference</i>	<i>Data Sheet</i>
Strap-on temperature sensor	QAD22	N1801
Immersion temperature sensor	QAE212...	N1781
Solar panel sensor	QAP21.2	N1833
Cable temperature sensor	QAP21.3	N1832

Technical design

- Application**
- Seven standard application types are preset into the controller and activated by DIP switch (refer to chapter "Mechanical design"). **All** applications (1...7) contain the basic differential temperature control loop described below.

- Basic Control**
- The controller switches its control output when the set temperature differential (setpoint) is reached.
- The following settings are required:
- The setpoint, that is, the temperature differential required between the 2 plant components or sections
 - The switching differential
 - The minimum charging temperature (optional operating mode)
- An external temperature sensor (B2) is used to measure the heat source temperature. The heat consumer temperature (N1) is measured with the controller's integral sensing element.

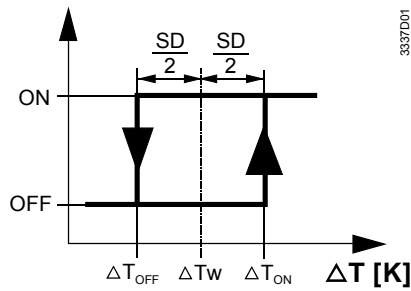

Δt K	Differential temperature
Δt W	Differential temperature setpoint
Δt_{ON}	Switch-ON point
Δt_{OFF}	Switch-OFF point
SD	Switching differential

If the source temperature (B2) exceeds the consumer temperature (N1) by the setpoint (Δt_{ON}), the controller closes its control contact Q1–Q3, thus switching the actuating device ON. If this difference falls below the setpoint (Δt_{OFF}), the controller closes its control contact Q1–Q2, thus switching OFF the actuating device.

Minimum charging temperature (B2)

On the controller, a minimum charging temperature can be set (setting with **setting slider 3**).

The controller switches its control output when

- the set temperature differential (setpoint) is reached **and**
- the minimum external temperature (B2) is reached

To enable this function, the operating mode Min. charging temperature must be selected (refer to chapter “Mechanical design”).

Setpoint temperature (B3)

With application types 2, 3 and 4, an absolute temperature can also be set. The controller switches its output ON (control contact Q4–Q6) when the temperature measured by sensor B3 falls below the value set at **potentiometer 4**. The output is switched OFF again (control contact Q4–Q5) when the temperature exceeds the setpoint by a fixed switching differential of 6 K.

Maximum temperature

With application types 1 and 2, a maximum temperature can also be set. When the temperature measured by sensor B3 reaches the limit value set at **potentiometer 5**, the controller closes its control contact (Q1–Q2), thus switching the actuating device **off**. When this temperature falls below the setpoint by a fixed switching differential of 10 K, the controller closes its control contact (Q1–Q3) and the actuating device is switched back ON again.

Switching the potentiometer to OFF disables the function.

Remote setpoint adjustment

Where the controller is mounted in an inaccessible location, a remote setpoint adjuster BSG21.1 can be connected to the RLE127 (terminals R1–M), thus enabling the setpoint to be adjusted from a remote location. In this case, the controller’s setpoint setting slider must be set to EXT.

Test mode

For the test mode, DIP switch no. 6 must be set to Test mode (refer to chapter “Mechanical design”). In test mode the main setting slider can be used to manually switch the relay contacts:

- If setting slider is in the **Mid** position ($>5 \dots <25$ K), the output relay contacts (Q1–Q2; Q4–Q5) remain normally closed as the factory settings.
- If setting slider is moved to the **High** position (>25 K), contact Q1–Q3 will close
- If setting slider is moved to the **Low** position (<5 K), contact Q4–Q6 will close

Mechanical design

The controller is designed for mounting into piping or onto storage tanks. It consists of housing, cover and immersion rod. The rod contains the sensing element (LG-Ni 1000). The housing is made of plastic and accommodates the controller electronics and all operating elements, which are accessible only after removing the cover. The front carries the setpoint setting slider and an LED for indicating operation:

- LED lit: normal operation
- LED flashes fast (4 Hz): Test mode
- LED flashes slow (1 Hz): Fault (B2)

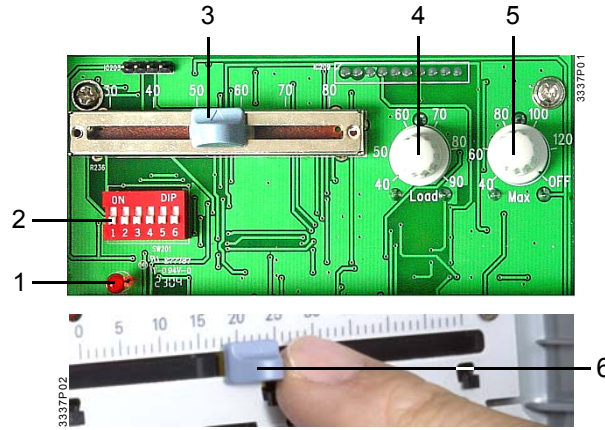

- 1 LED for test mode/fault B2/normal operation
- 2 DIP switch block
- 3 Setting slider for minimum charging temperature
- 4 Potentiometer for loading temperature (40...90 °C)
- 5 Potentiometer for maximum temperature (40...130 °C)
- 6 Setting slider for Δt setpoint (1...30 K)

All functions are selected via the DIP switch block, which comprises 6 switches. The applications are preset into the controller and can be selected using switches 4 and 5 (refer to chapter “Application examples”).

Function	1	2	3	4	5	6	Action
Switching differential	<input type="checkbox"/>	<input type="checkbox"/>					Switching differential = 8 K
	<input type="checkbox"/>	<input type="checkbox"/>					Switching differential = 1 K
	<input type="checkbox"/>	<input type="checkbox"/>					Switching differential = 4 K
	<input type="checkbox"/>	<input type="checkbox"/>					Switching differential = 2 K
Operating mode (B2)			<input type="checkbox"/>				With min. charging temperature
			<input type="checkbox"/>				Without min. charging temperature
Application type (B3)				<input type="checkbox"/>	<input type="checkbox"/>		Applications 6, 7: 2 Exchangers (Δt)
				<input type="checkbox"/>	<input type="checkbox"/>		Application 5: 2 Collectors (Δt)
				<input type="checkbox"/>	<input type="checkbox"/>		Applications 3, 4: Bypass (°C)
				<input type="checkbox"/>	<input type="checkbox"/>		Applications 1, 2: Standard
Test mode						<input type="checkbox"/>	Test mode
						<input type="checkbox"/>	Normal operation

Note The default setting (factory delivered) for all 6 switches is OFF.

Mounting notes

For mounting, a protection pocket is provided; the controller is inserted and snaps on. Suitable mounting locations for the controller or the temperature sensor depending on the application:

- In the heat source: in the hottest part
- In the heat consumer: in the coldest part
- In solar panels: directly by the outlet

Ensure that the local safety regulations are complied with.

To mount the protection pocket, a threaded sleeve must be fitted into the pipe. The immersion rod should face the direction of flow. The maximum permissible ambient temperature must be observed.

The controller is supplied complete with Mounting and Installation Instructions.

Commissioning notes

- To check the control wiring, the controller can be switched into test mode so that the response of the actuating device(s) can be checked.
- If the control is unstable, increase the switching differential; if it is too slow, decrease the switching differential.
- If the temperature sensor at the heat source (B2) is faulty or disconnected, all outputs will be switched OFF and the red LED will flash (slow).

Technical data

Power supply	Operating voltage	AC 230 V +10% / -15%
	Frequency	50 / 60 Hz
	Power consumption	max. 4 VA

Functional data	Setting range setpoint temperature differential	0...30 K
	Setting range minimum charging temperature	30...80 °C
	Setting range absolute temperature	40...90 °C
	Setting range maximum temperature	40...120 °C
	Switching differential	
	Main Δt control loop	selectable (1 / 2 / 4 / 8 K)
	Absolute temperature	fixed (6 K)
	Maximum temperature	fixed (10 K)
	Control outputs (Q1–Q2/Q3), (Q4–Q5/Q6)	
	Voltage	AC 24...230 V
Current	max. 2 A	
Max. cable length copper cable 1.5 mm ² for signal inputs B2, B3		80 m

Environmental conditions	Operation		
	Climatic conditions	to IEC 721-3-3, class 3K5	
	Temperature	0...+50 °C	
	Humidity	<95 % r.h.	
	Transport		
	Climatic conditions	to IEC 721-3-2, class 2K3	
	Temperature	-25...+70 °C	
	Humidity	<95 % r.h.	
	Mechanical conditions		class 2M2

Norms and standards	CE conformity according to	
	EMC directives	89/336/EEC
	Low voltage directive	73/23/EEC and 93/68/EEC
	Product standards	
Automatic electrical controls for household and similar use	EN 60 730-1 and EN 60 730-2-9	

Electromagnetic compatibility	
Emissions	EN 50 081-1
Immunity	EN 50 082-1
Degree of protection	IP 42 EN 60 529
Safety class	II to EN 60 730
Degree of contamination	Normal

General

Connection terminals for solid wires or stranded wires	2 × 1.5 mm ² or 1 × 2.5 mm ²
Sensor	
Sensing element	LG-Ni 1000 Ω at 0 °C
Time constant (with protection pocket)	25 s
Protection pocket	
Immersion depth	150 mm
Perm. nominal pressure	PN10
Made of	brass (Ms63)
Weight	0.3 kg

Connection terminals

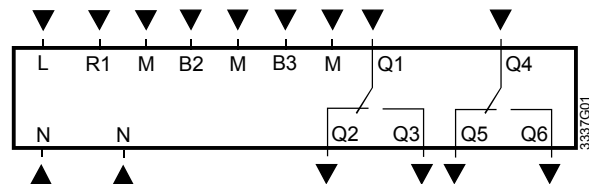

- B2, B3 Temperature sensors
- L, N Operating voltage AC 230 V
- M Ground
- Q1, Q4 Input for control contact
- Q2, Q5 Output for control contact (normally closed)
- Q3, Q6 Output for control contact (normally open)
- R1 Input for remote setting unit

Connection diagrams

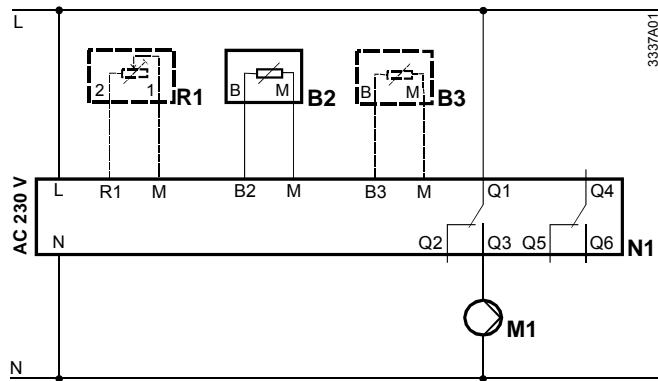

Differential temperature controller with remote setpoint adjuster and 2 external temperature sensors, with maximum limitation. Control of a charging pump (e.g. application no. 1)

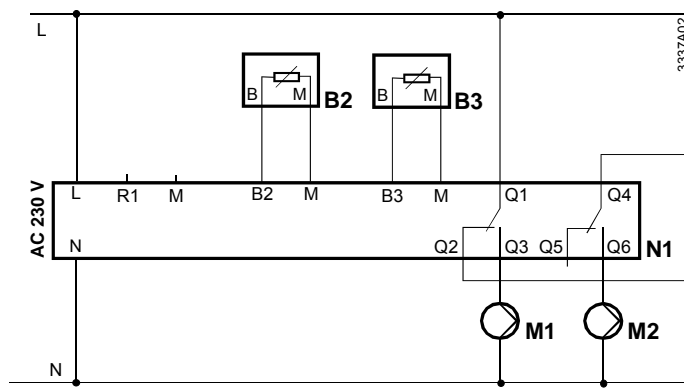

Differential temperature controller with a solar temperature sensor and a storage tank temperature sensor. Control of solar pump and boiler pump (e.g. application no. 2.)

Note

In this example, the input for control contact Q4 is fed from the normally closed contact Q2. This prevents both charging pumps from running simultaneously.

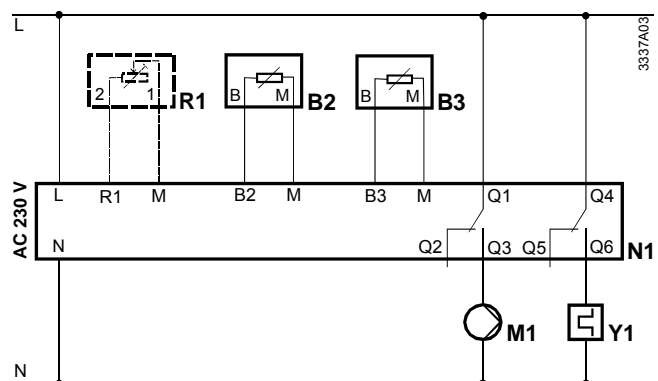

Differential temperature controller with 2 external temperature sensors. Control of a charging pump and a 2-position actuator (e.g. application no. 3)

- B2 External temperature sensor (heat source)
- B3 External temperature sensor
- M1 Charging pump
- M2 Charging pump 2 (secondary heat source e.g. boiler)
- N1 Immersion temperature controller RLE127
- R1 Remote setpoint adjuster BSG21.1
- Y1 Actuator for changeover valve

Application 1
Standard Solar System

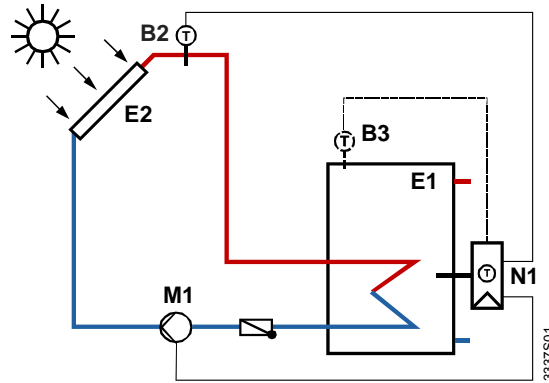

Basic differential temperature control of a storage tank. The temperature difference between the solar collector (measured by sensor B2) and the internal temperature (N1) is compared with the Δt setpoint. The charging pump M1 is activated when the set differential is reached.

Application 2
Solar System with Additional Heat Producer

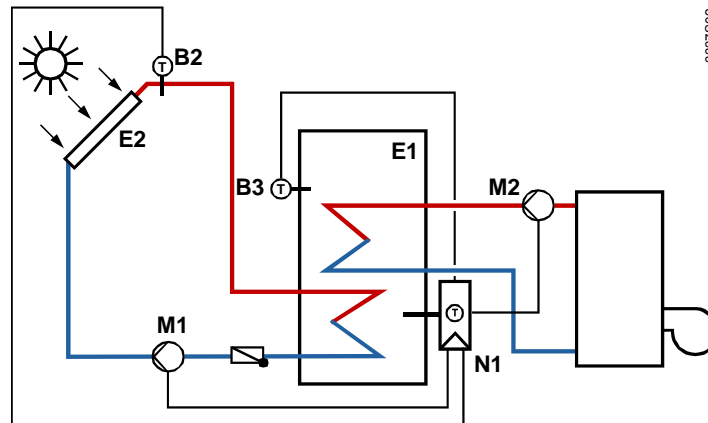

Differential temperature control of a storage tank with changeover to a separate heat producer (typically a boiler) when the solar energy is not sufficient. An additional sensor (B3) is added to the upper part of the storage tank to control charging pump M2 to maintain a fixed boiler temperature.

Application 3
Solar System with Diverting Valve (Bypass)

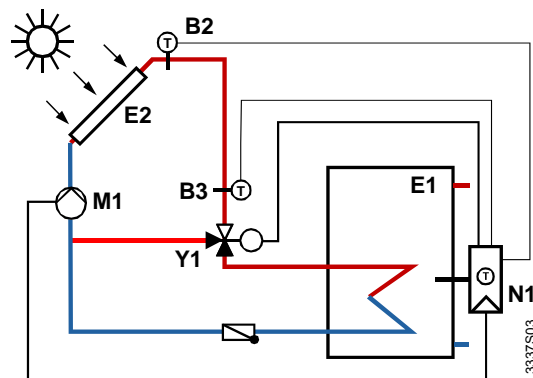

Differential temperature control of a storage tank with an additional sensor (B3) in the flow from the collector and a bypass valve (Y1). This application is used where the collector is a long way from the storage tank (e.g. on a high roof) and prevents cool water in the pipe work from being fed into the tank (typically on morning start up or after long periods without solar energy).

Application 4
Solar System with Heat Exchanger (Buffer)

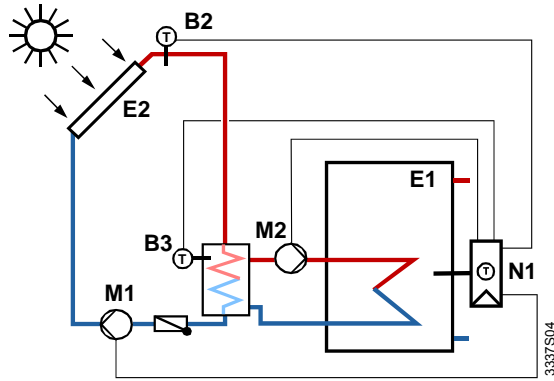

Differential temperature control of a storage tank with an additional buffer tank or heat exchanger used between the solar collector and main storage tank. An additional sensor (B3) measures the temperature in the heat exchanger, and the storage tank is only charged when the exchanger temperature reaches the required setpoint.

Application 5
Solar System with 2 Collectors (East/West)

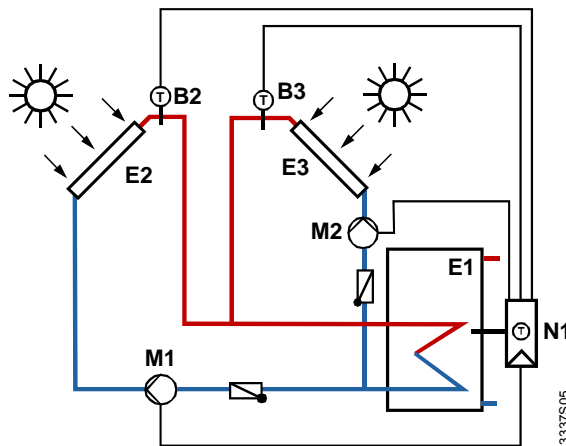

Differential temperature control of a storage tank by two independent solar collectors (e.g. east and west facing). This application is used in very sunny areas to maximize the solar energy throughout the day.

Application 6
Solar System with layered Storage Tank (2 heat exchangers)

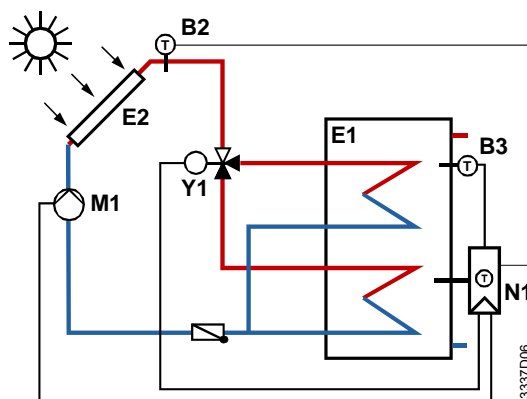

Differential temperature control of a layered storage tank. During periods of low solar energy this application maximizes the heat available by charging the lower part of the storage tank only. As the solar energy increases, the bypass valve (Y1) closes and the upper part of the tank is charged.

Application 7
Solar System with 2 Storage
Tanks and 1 Collector

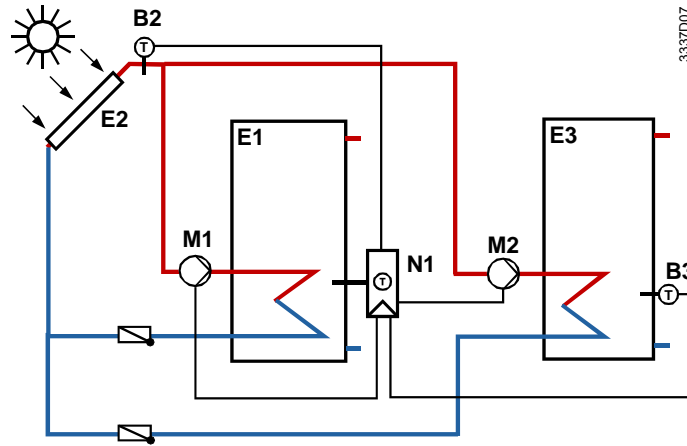

This application uses a single solar collector to charge two storage tanks in parallel. It is typically used where the sun's energy is very high or can be used for long periods

- B2 External temperature sensor (heat source)
- B3 External temperature sensor
- E1 Heat consumer (storage tank)
- E2 Primary heat source (solar collector)
- E3 Secondary heat source (boiler or solar collector)
- M1 Charging pump 1
- M2 Charging pump 2
- N1 Immersion temperature controller RLE127
- R1 Remote setpoint adjuster BSG21.1
- Y1 Actuator for changeover/bypass valve

Dimensions

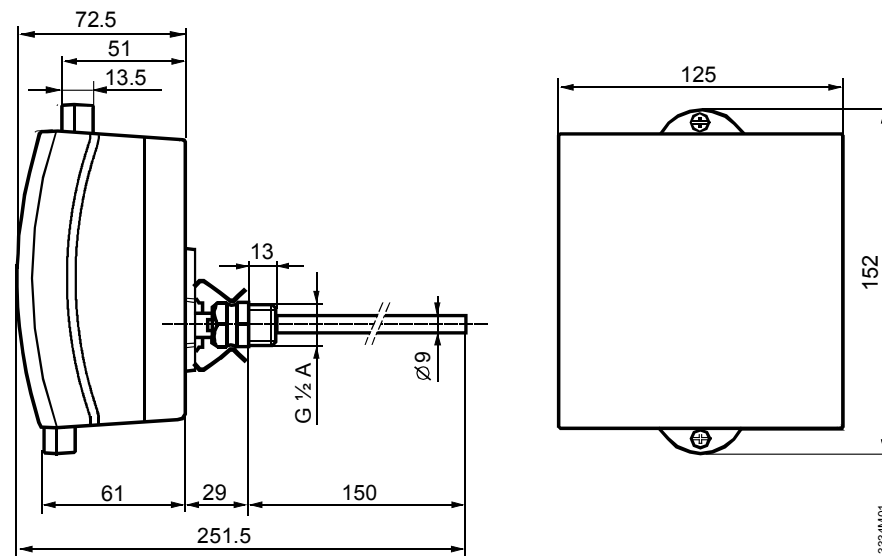

Controller with protection pocket

Dimensions in mm