

Cerberus® DLO1191 Linear smoke detector

Technical description
Planning
Installation
Commissioning



Cerberus
Security
for People
and Assets

Siemens Building Technologies
Cerberus Division

Data and designs subject to change
without notice/Supply subject to
availability
© Copyright by
Siemens Building Technologies AG

We reserve all rights in this document
and in the subject thereof. By
acceptance of the document the
recipient acknowledges these rights
and undertakes not to publish the
document or the subject thereof in
full or in part nor to make them
available to any third party without our
prior express written authorization,
nor to use it for any purpose other
than for which it was developed or in

1	Overview	1
1.1	Characteristics	1
1.2	Design	2
1.3	Operating principle	3
2	Technical data	4
2.1	Collective mode	4
2.2	Interactive Mode	4
2.3	General data	5
3	Design and principle of operation	6
3.1	Detector	6
3.2	Structure of the infrared beam	6
3.3	Alignment possibilities	7
3.4	Reflectors	8
3.5	Compatibility	8
3.6	Description of block diagram	9
3.7	Functions in operation with interactive system	10
3.7.1	Emergency operation	10
3.7.2	Line isolation function	10
3.7.3	Diagnostic facilities	10
3.7.4	Self-test / functional state	11
3.8	General detector functions	11
3.8.1	Alarm algorithms	11
3.8.2	Fuzzy Logic	15
3.8.3	Possible diagnosis results	16
4	Planning	17
4.1	General project engineering principles	17
4.2	Operating conditions	17
4.3	Fields of application	18
4.3.1	Examples of suitable fields of application	18
4.3.2	Examples of unsuitable fields of application	18
4.4	Monitoring areas with flat ceilings	19
4.5	Monitoring areas with sloping ceilings	19
4.5.1	Additional DLO1191's on the slope of the ceiling	19
4.6	Monitoring areas with joist constructions	21
4.6.1	Layout underneath joist construction	21
4.6.2	Layout within the joist area	21
4.6.3	Detection of smouldering fire in high rooms	22
4.7	Guideline for distances between DLO1191 and reflector	22
4.8	Panes of glass	23
4.8.1	Penetration of panes of glass	23
4.8.2	Application example	24
4.8.3	Reflectors mounted on glass walls	24
4.9	Minimum distances between two pairs of detectors	25
4.10	Beam spacing from the ceiling	25
4.11	Maximum monitoring width	26
4.12	Measures for dividing long distances	26
4.13	Measures against condensation	26
4.14	Installation locations	27
4.15	Accessibility	28
5	Installation	29
5.1	Mounting	29
5.2	Wiring	30
5.2.1	Special filter	30
5.2.2	Detector heater	30
5.3	Interactive mode	31
5.4	Collective mode	31

5.5	Connection	31
6	Commissioning	32
6.1	Settings	32
6.2	Mechanical adjustment	33
6.3	Electronic alignment	34
6.4	Initialization	35
6.5	Addressing in the interactive system	35
7	Faults / overhaul	36
7.1	Fault	36
7.1.1	Interruption to beam	36
7.2	Reflection	36
7.3	Checklist for trouble-shooting	36
7.4	Functional check / overhaul	37
8	Terminology	38

1 Overview

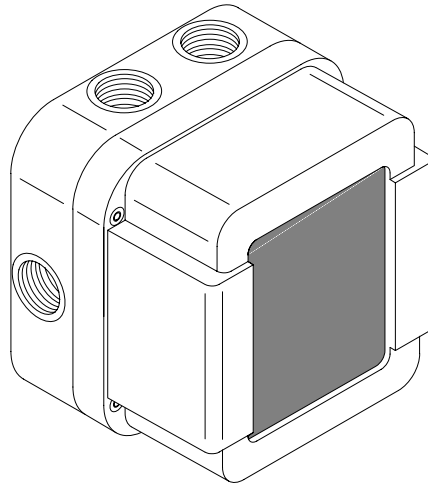

1.1 Characteristics

- **Directly connectible to the Cerberus interactive system *AlgoRex*[®]**
- **Switchable to collective systems**
- **Microprocessor-controlled signal processing**
- **Suitable for surveillance ranges from 5 to 100m**
- **Operates according to the principle of light-attenuation by smoke**
- **Response behavior selectable in 3 sensitivity stages**
- **Transmission of 4 danger levels per sensitivity setting**
- **Transmission of four function states:**
normal, information, impairment, fault
- **Automatic digital compensation of ambient influences**
- **High immunity to extraneous light**
- **Transmitter and receiver installed in the same housing**
- **Easy installation, adjustment and commissioning**
- **Two-wire installation**
- **Comprehensive accessories**
- **New diagnostic capabilities with fuzzy logic**
- **Efficient signal processing algorithms with application-specific characteristics**
- **Comprehensive EMC concept based on the latest technologies**
enables the detector to be installed in difficult environments
- **Integrated multi-coincidence circuit**
suppresses extreme electrical and optical noise signals
- **Automatic and comprehensive self-test**

1.2 Design

The BeamRex DLO1191 comprises:

- Base DLB1191A consisting of:
 - Terminal support with terminals

The base is required already at the time of installation. The base housing features six PG16 tapped cable inlets.

- Detector module DLA1191A consisting of:
 - Transmitter
 - Receiver
 - Lens
 - Electronics

The plug-in detector module is inserted just prior to commissioning.

The lens can be optimally aligned to the reflector by means of the adjustment set.

Reflectors

Different reflectors are available for different distances:

- | | |
|--------------|---|
| – 5 to 30m | Reflector foil DLR1193 (10 x 10cm) 1 pc. |
| – 30 to 50m | Reflector foil DLR1192 (20 x 20cm) 1 pc. |
| – 50 to 65m | Reflector foil DLR1192 (20 x 20cm) 4 pcs. |
| – 20 to 100m | Prism made of glass DLR1191 (cat's eye) 1 pc.
with built-in heating against condensation |

Short distance filter

For shorter distances between 5 and 10 m an additional short distance filter is required:

- | | |
|--|------------|
| – 5 to 8m | DLF1191-AB |
| – 7 to 10 m | DLF1191-AA |
| – Filter against external light influences | DLF1191-AC |

The detector is rarely influenced by external light. If, however, powerful external light causes interference, the filter DLF1191-AC can be used to eliminate this.

Accessories:

- Detector heater DLH1191 for DLO1191, against condensation of the lens

Auxiliary tools:

- Detector adjustment set DZL1191 consisting of:
 - Adjustment device
 - Test filter
 - Aiming device

1.3 Operating principle

The linear smoke detector operates on the basis of the extinction principle, i.e. the reduction in light intensity due to smoke is measured. The transmitter (IRED) emits a strongly focused infrared light bundle along the optical measuring section. Without smoke a large part of the beams attains the reflector and is sent back in the same direction toward the receiver. The arriving light produces an electrical signal on the photodiode of the receiver.

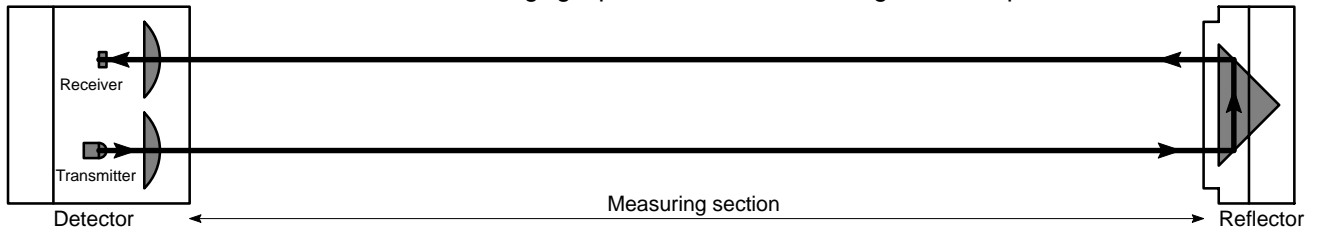

Fig. 1 Linear smoke detector without smoke

If smoke penetrates the measuring section, part of the light beams is absorbed by the smoke particles while another part is scattered by the smoke particles, i.e. the light beams merely change direction. The remaining light reaches the reflector. The remaining light is then reflected and once again passes through the measuring section and is further attenuated. Thus only a small portion of the beam reaches the receiver and the signal (S_{smoke}) becomes smaller.

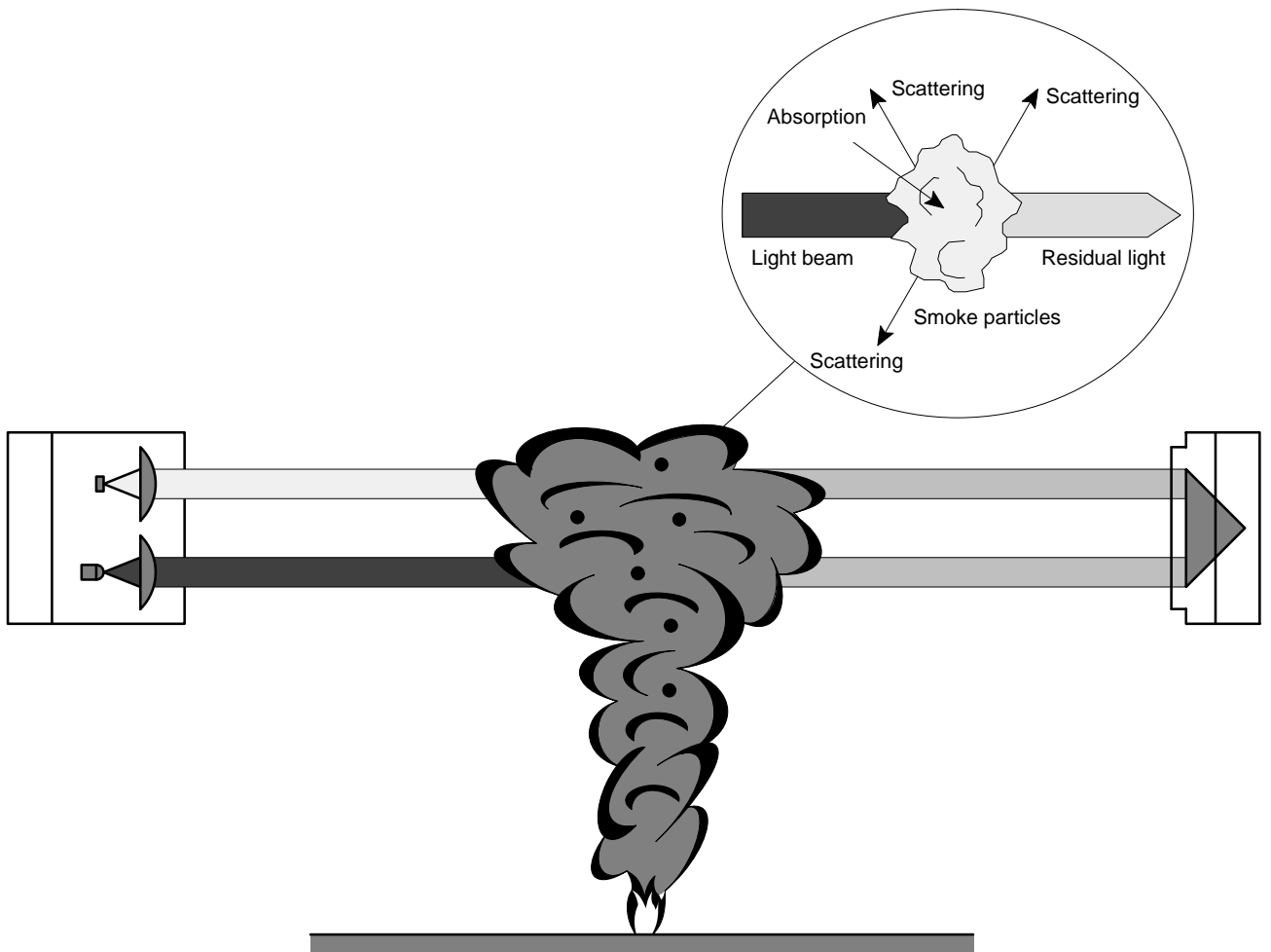

Fig. 2 Measuring principle of the linear smoke detector with smoke
 Extinction = Absorption + Scattering

2 Technical data

Normal ambient conditions, if nothing else is specified:

Temperature T_a = 20°C (293K)

Air pressure: p = 1'000hPa (750 Torr)

2.1 Collective mode

Parameters	Symbol	Value				Conditions
		Unit	min.	typ.	max.	
Operating voltage (quiescent)	U_b	V	18		28	
Maximum permissible voltage	U_{max}	V			30	
Switch-on current	I_e	mA			2.8	
Operating current (quiescent condition)	I_b	mA		1.5	2.8	
Alarm voltage at $I_A = 1 \dots 10\text{mA}$	U_A	V	5		11	
Alarm current at $U_b = 24\text{V}$	I_A	mA	40		75	
Reset voltage	U_R	V	2		6	
Reset current	I_R	μA	5		500	
Reset time ($U_R = 2\text{V}$)	t_R	s			2	
Response indicator Voltage	U_{ie}	V	3		6	permanent pulsed $f \geq 0.5\text{Hz}$, Duty Cycle 50% depending on line module
Response indicator Current	I_{ie}	mA			60 100	
Response indicator Flashing frequency		Hz		1		
Connection factor	KMK	–	–	25	–	maximum 1 detector per detection line

2.2 Interactive Mode

Parameters	Symbol	Value				Conditions
		Unit	min.	typ.	max.	
Operating voltage (quiescent)	U_b	V	21.2		33.3	modulated
Operating current (quiescent condition)	I_b	mA		1.5		
Baud rate		kBd		4.8		
Response indicator Flashing intervals: light dark		ms s		20 1.5		depending on control unit
Response indicator current		mA		15		
Connection factor	IMK	–	–	10	–	Isolator factor = 1

2.3 General data

Parameters	Symbol	Value				Conditions
		Unit	min.	typ.	max.	
Distance between detector and reflector	L	m	8		100	<10m filter DLF1191-AA
Additional area (without approval)			5		8	Filter DLF1191-AB
Response sensitivity reduced	D ₁	%		65		Attenuation of the beam (forward and return path)
standard		%		50		
increased		%		30		
Compensation (if beam is attenuated)		%			50	
Compensation speed		%/h			4	
Self-test interval		min.		15		
Alarm integration		s	6		16	Dependent on diagnosis
Fault activation		%		>90		Attenuation of the beam
IR transmitter Wavelength		nm		880		Attenuation of the beam
Pulse frequency		Hz		6		
Pulse length		µs		25		
Elektromagnetic compatibility		V/m	50			1MHz...1GHz
Operating temperature	T _a	°C	-25		+60	
Humidity ≤30°C >30°C					≤95% rel. ≤29g/m ³	
Storage temperature	T _l	°C	-30		+75	

Colour: pure white ~RAL9010

Detector heater DLR1191 / DLH1191

Supply voltage	U _H	V _{DC}	20		30	
Operating current	I _H	mA	33		50	
Resistance	R	Ω		600		

Classification

Standards	BS 5839: Part 5
	CE conformity marking
Application category	IEC 721-3: 3K6
Test category	IEC 68-1: 25/060/42
Protection category	EN60529 / IEC529: IP65

Compatibility

To *AlgoRex* interactive fire detection system with AlgoLogic S11
To Cerberus control units with collective detector evaluation

Environmental compatibility:

- Easy to overhaul
- Easy to uninstall and disassemble
- Plastic material identifiable through embossed code

3 Design and principle of operation

3.1 Detector

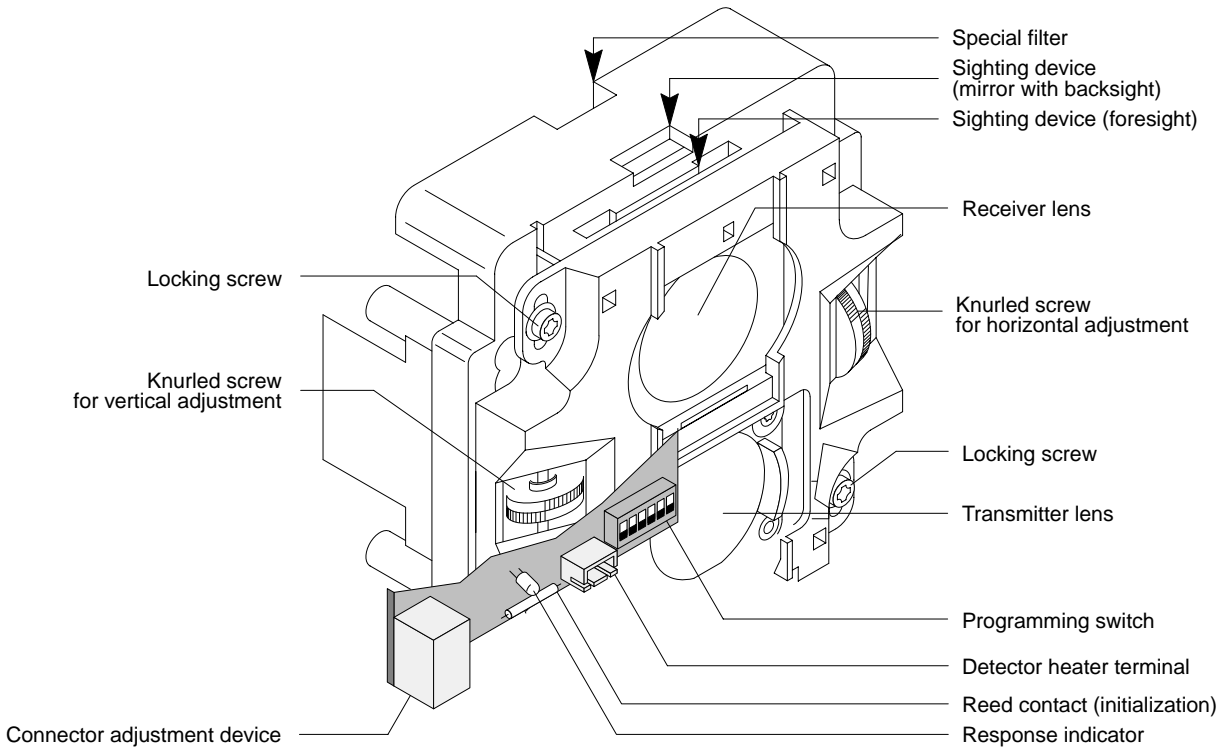

Fig. 3 Detector

3.2 Structure of the infrared beam

The infrared beam emitted by the transmitter to the reflector is not a strictly parallel bundle of rays. It exhibits a certain degree of scattering which makes it conical in shape. The radiation energy decreases towards the outside, so that the beam can be divided into the three effective, core and scattered regions. The reflector possesses the characteristic to retransmit the received light.

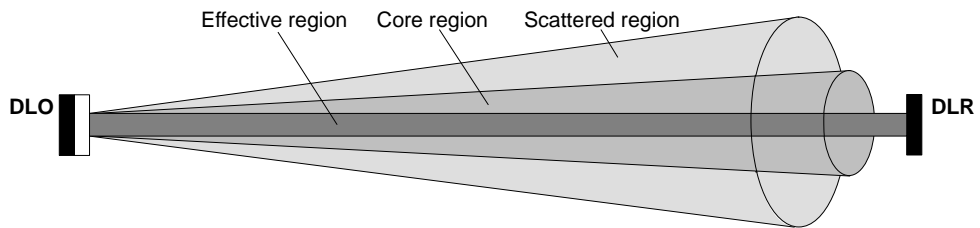

Fig. 4 Structure of the infrared beam

- The effective region corresponds to the ribbon connecting transmitter, reflector and receiver.
- The core region contains sufficient radiation energy to operate the system.
- The energy in the scattered region is not sufficient to ensure reliable operation of the system.

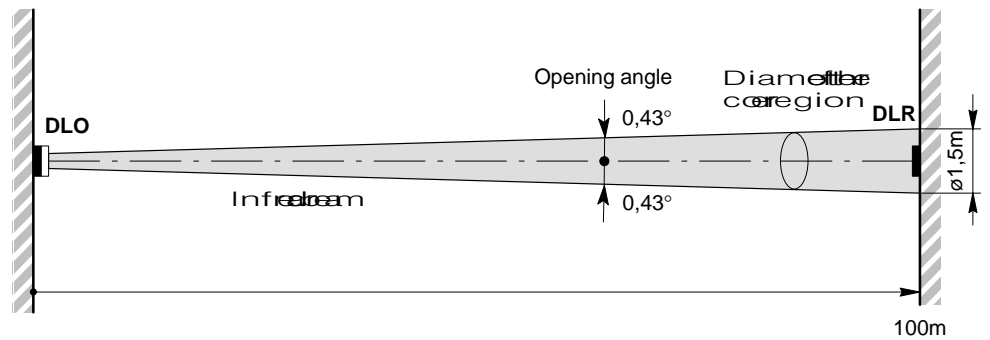

Fig. 5 Diameter of the core region

3.3 Alignment possibilities

- The infrared beam can be adjusted by each 10° in horizontal direction and each 5° in vertical direction from the centre axis. When selecting the optimum mounting location bear in mind that this adjustment range can be fully used. Experience has shown that the detector and reflector should be arranged as parallel as possible especially with distances of $>50\text{m}$, as this makes adjustment simpler.

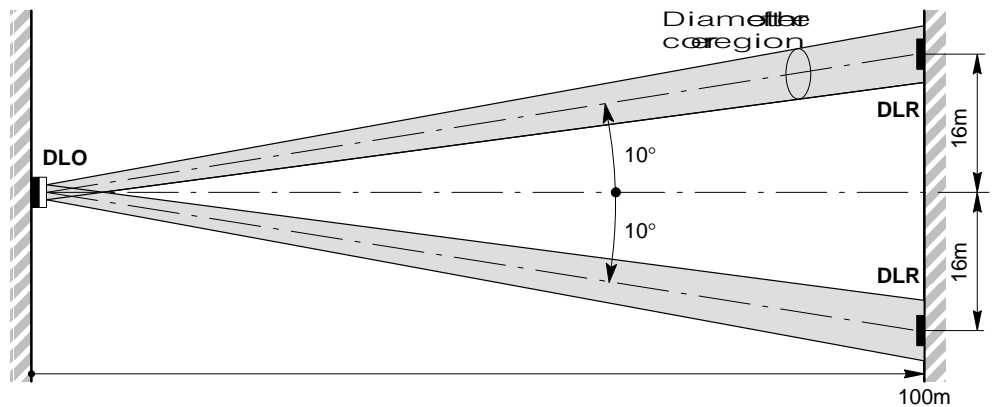

Fig. 6 Horizontal adjustment range of the optical system max. 10° each side of the axis

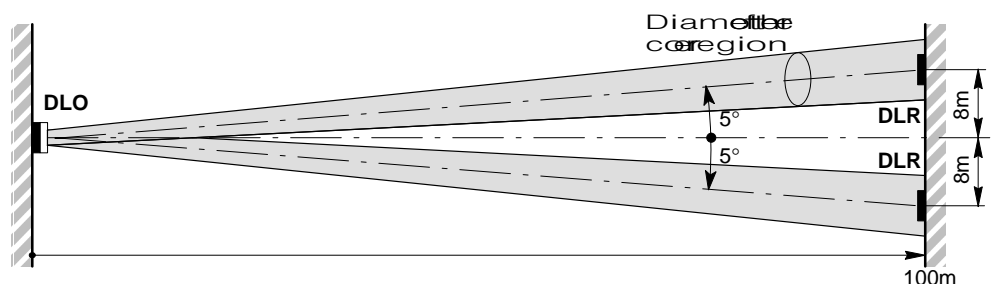

Fig. 7 Vertical adjustment range of the optical system max. 5° above and below the axis

- One rotation of the knurled screw moves the beam at 100m approx. 1.15m.

3.4 Reflectors

Retroreflectors reflect the received light beam in parallel to the latter. For this reason the reflector does not have to be installed thereby mandatory right-angled to the infrared beam. Also vibrations and distortions of the reflector mounting wall do not cause any problems. Another advantage is that any extraneous light is also reflected in its own direction and consequently does not reach the receiver.

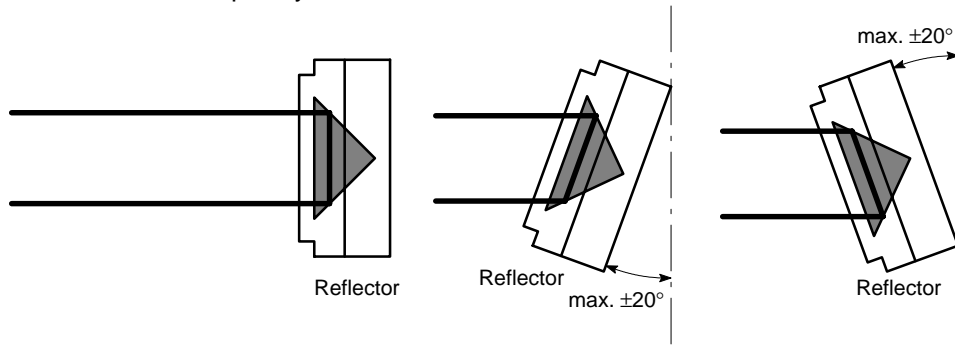

Fig. 8 The reflector and reflector foil can be mounted inclined max. $\pm 20^\circ$ in all directions

DLR1191 prism

The retroreflecting prism has the shape of a pyramid whose lateral faces are formed by isosceles orthogonal triangles. Light beams entering through the base are completely reflected twice on the lateral faces and reflected back through the base.

The prism is installed in a housing that is identical to the one used for the detector base. The reflector is equipped with a reflector heater at the factory. If dew condensation is possible the heater should be connected to a 24V supply.

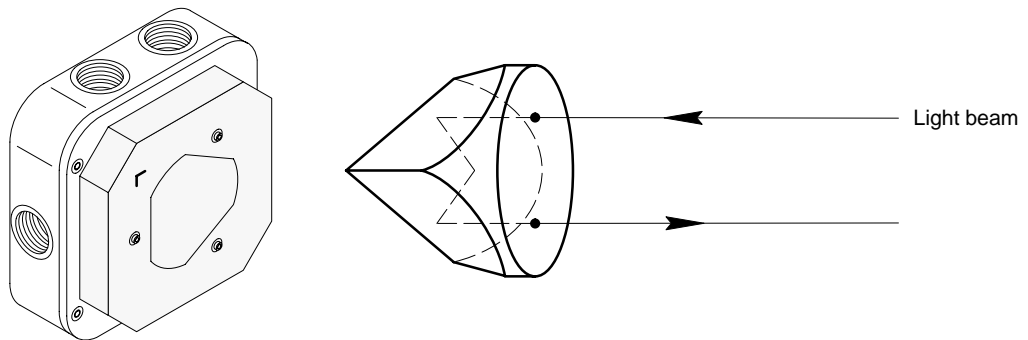

Fig. 9 DLR1191 reflector and reflection principle

DLR1192, DLR1193 reflector foil

This foil consists of microprismatic elements that are formed by transparent, synthetic resin sealed to a plastic substrate. In principle, the reflector foil has the same effect (function) as the prism.

3.5 Compatibility

	Interactive	Collective
Fire detection system	S11	S11, MS9
Control unit	CS1140	CS11..., CZ10

3.6 Description of block diagram

The transmitter **1** transmits the light pulses to the reflector **2**. This transmits the light pulses back to the receiver **3**. The light pulses are proportional to the signal current, which is amplified in the preamplifier **4** and fed to the customer-specific integrated circuit (ASIC) **5**. The microprocessor (μ P) **6** synchronizes the receiver pulses with the transmitter pulses so that no external pulse is evaluated.

The sensor-specific functions are contained in the ASIC. It is used to filter signals, process signals using fuzzy algorithms, amplify signals and for the entire sequence control which is synchronized with the μ P.

The μ P communicates with the control unit via the line interface **7** via terminals **8** and the two-wire bus line. The detector receives commands which activate the type of operating mode, diagnostic stages etc. via the data interface which is integrated in the line interface. The detector transmits response signals, the results of diagnostic polling and status signals back to the control unit.

With the help of the isolation function, sections which malfunction are "isolated", so that in the event of a short circuit, the entire bus line does not break down. Upon short circuit, two "electronic switches" (FET) open automatically and isolate the line in the area where the malfunction has occurred until the short circuit has been eliminated.

The internal response indicator (AI) **9** and the external response indicator **10** provide indication of alarm and are activated by the control unit.

The 6 DIP switches **11** allow parameterization of the detector (see section 6.1).

The REED contact **12** serves to initialize the detector during commissioning (see section 6.4).

A detector heating device, which prevents condensation of the lenses, can be connected to detector heating terminal **13**.

The DZL1191 adjustment device can be connected via connector **14**. The purpose and function of the adjustment device is explained in section 6.3 (electronic alignment)

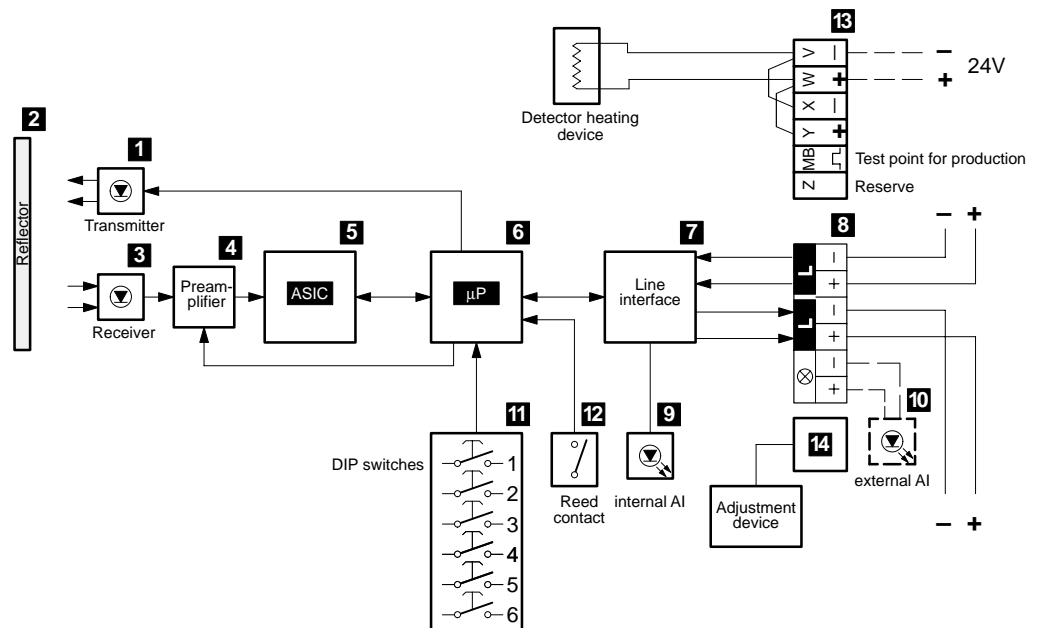

Fig. 10 Block diagram

3.7 Functions in operation with interactive system

3.7.1 Emergency operation

If the DLO1191 can no longer be polled by the control unit, for example, due to a μ P failure, it switches automatically to emergency operation. In the event of a fire this detector is still able to trigger a collective alarm.

3.7.2 Line isolation function

If a short circuit occurs on the detector bus line, detectors with separator prevent failure of the entire bus line because only the defective portion of a line is isolated. The DLO1191 features such a isolation function. Before and after the detector an electronic switch (FET) is installed in the bus line. This switch opens automatically in the event of a short circuit and the defective portion of the detector line is disconnected.

3.7.3 Diagnostic facilities

A detector can transmit four events to the control unit:

- Danger level 0 (quiescent value)
- Danger level 1 (possible danger)
- Danger level 2 (probable danger)
- Danger level 3 (highly probable danger)

Danger level 1 For early warning where installation locations are critical, the number of times the threshold to danger level 1 is exceeded is counted by the control unit. When the counter reaches a preset value an information «application warning» is displayed. This information is registered in the event memory of the basic parameterization of the control unit.

Danger level 2 The occurrence of danger level 2 causes the actuation of an information «Warning» in the basic parameterization of the control unit. This information is also actuated in the event memory of the basic parameterization of the control unit.

Danger level 3 As a rule, this is a precondition for direct alarm actuation. Dual or multiple cross-zoning is possible through corresponding programming of the control unit.

Response threshold 1...3 corresponds to danger levels (G1 ... G3) for standard sensitivity

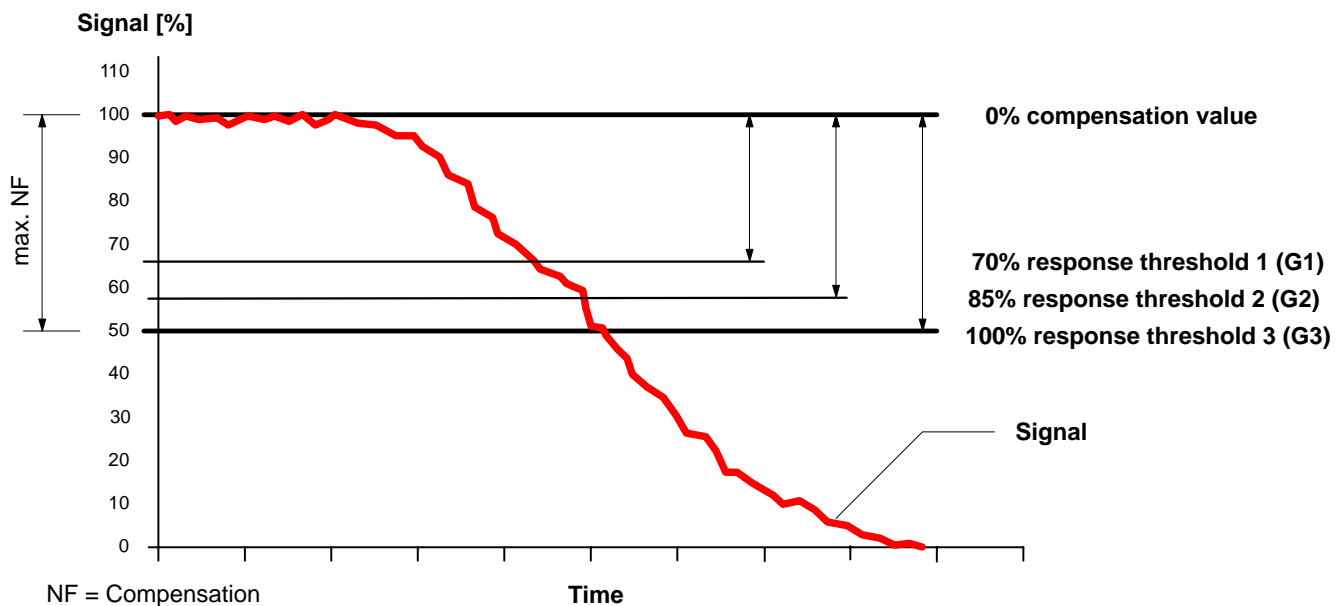

3.7.4 Self-test / functional state

Periodically or on request by the control unit a comprehensive detector self-test is initiated which monitors the signal amplifier and the EEPROM.

Also periodically monitored are the compensation value, line voltage, etc. The entire signal path is monitored with the compensation value. If the compensation value is too high or too low, a corresponding signal is generated.

If the detector signals status changes, the control unit is able to read out the cause from the detector memory.

- «Functional state 0» corresponds to «Normal state»
- «Functional state 1» corresponds to «Information»
e.g. thermal turbulence, repeated interruption of the beam, condensation
- «Functional state 2» corresponds to «Impairment»
e.g. compensation value too high/too low, voltage at reservoir capacitor is too low
- «Functional state 3» corresponds to «Fault»
e.g. data fault in the EEPROM, beam interruption, compensation value is invalid

3.8 General detector functions

3.8.1 Alarm algorithms

Compensation value

The compensation value (NFW) is the reference variable for the actual measurement signal. All thresholds, diagnostic functions and self-checking are based on the current compensation value.

The first compensation value (NFW) is set at the time of initialization. It is subsequently updated approx. every 60 minutes to compensate a slow drift of the measurement signal. This drift can be caused, for example, by contamination of the detector optics.

The maximum compensation is 50% of the total signal of 100%.

Response threshold

The response threshold corresponds to a danger level.

An alarm algorithm is activated when the response threshold drops.

According to the sensitivity setting, the response threshold is higher or lower.

Response threshold 3 of the different sensitivities

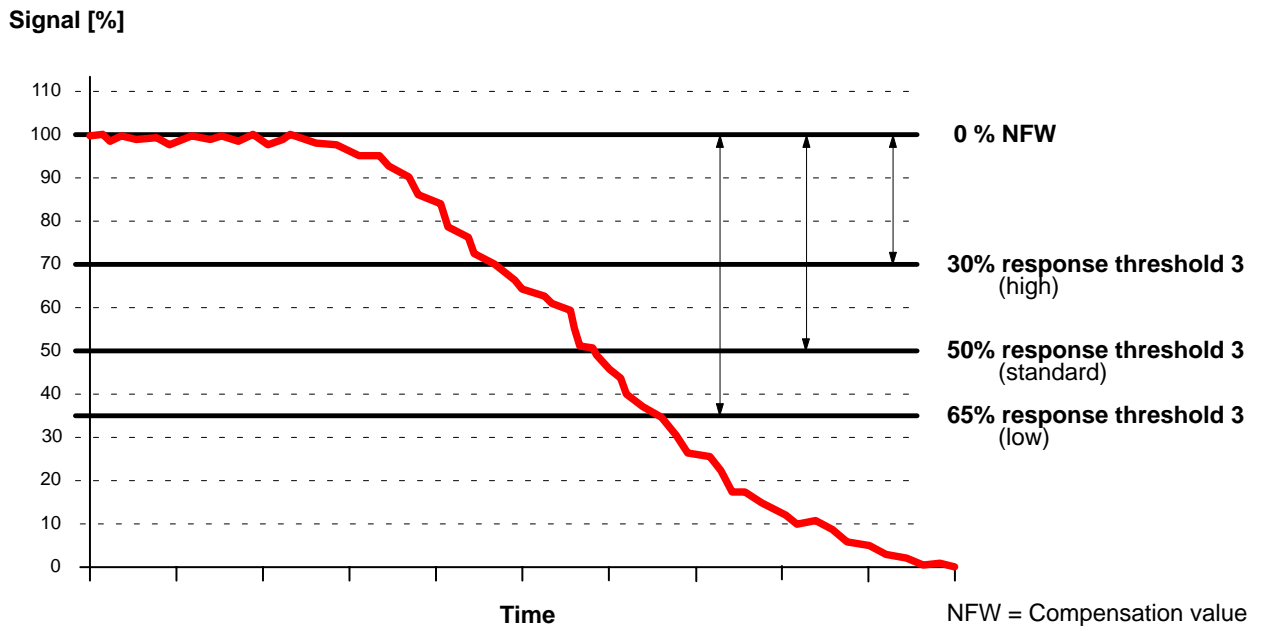

Smoothing

The measuring signal is measured with a 6Hz clock. The raw data are processed with so-called "smoothing filters" for subsequent evaluation. In this way extreme peak values caused by signal interference are "smoothed".

An alarm is triggered based on the smoothed signals.

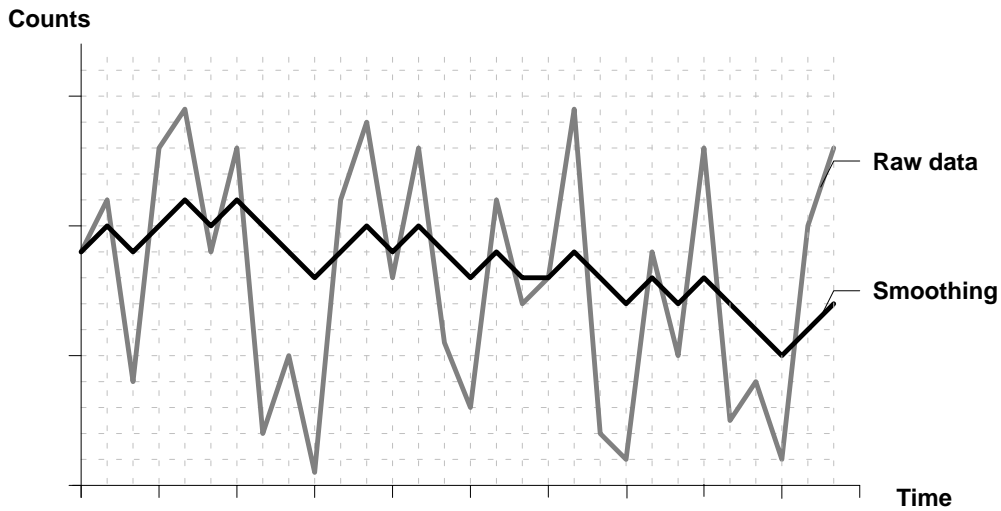

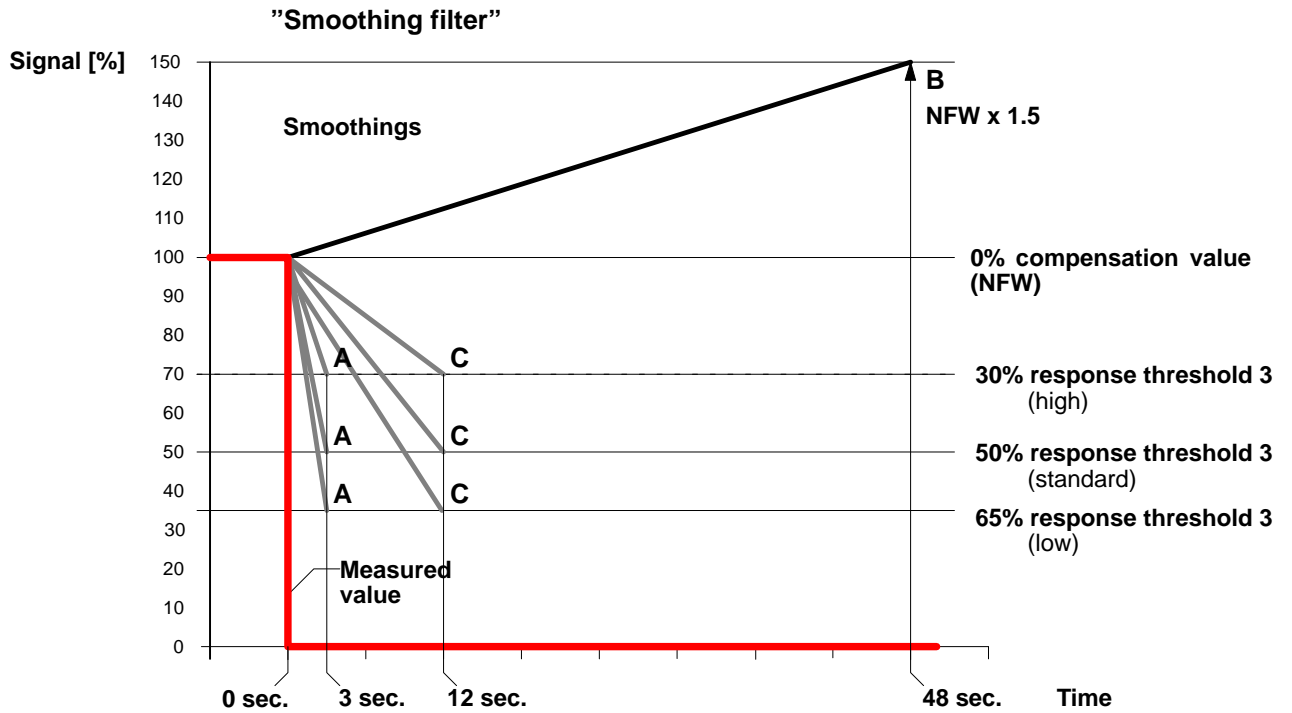

Three "smoothing filters" A, B and C are used. They are characterized by the time it takes to reach response threshold 3 of the corresponding sensitivity setting.

If the smoothed signal reaches response threshold 1 or 2, in the interactive system the corresponding mode is activated by means of the corresponding danger level. These levels are not evaluated in the collective system.

If the smoothed signal reaches response threshold 3, the alarms in the alarm counter are added up. Upon reaching the given value, danger level 3, i.e. an alarm is activated.

According to the diagnosis made, other alarm parameters are automatically selected:

- Diagnosis "Fire or slowly-developing fire" ⇒ alarm activation after ≤ 6s (smoothing A + 20 alarm counts)
- Diagnosis "Noise or repeated interruption" ⇒ alarm activation after ≤ 16s (smoothing C + 20 alarm counts)
- Diagnosis "Test filter" ⇒ alarm activation after ≤ 10s (smoothing A + 40 alarm counts)

Smoothing filter B filters out reflections.

Reflecting or shining surfaces, which are too near at the path of the beam, can impair the detector.

Smoothing B > actual compensation value x 1.5 = reflection

Application diagnoses

The detector has an automatic diagnosis evaluation facility based on complex fuzzy algorithms. The raw data are treated by 4 different filters. Each filter assesses a special characteristic of the signal: Gradient, noise, asymmetry, jump.

Filter

Typical events and results for the 4 filters:

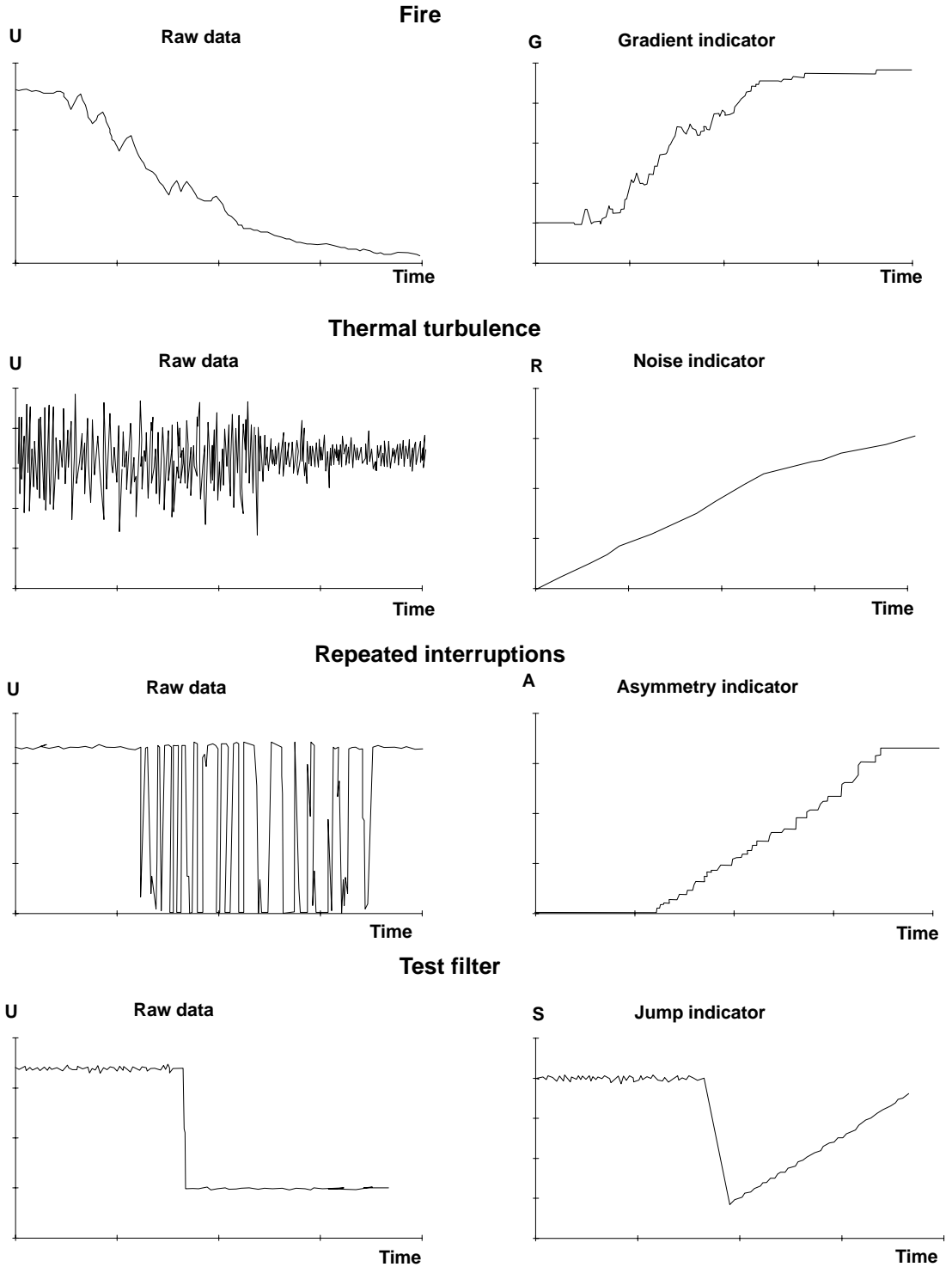

3.8.2 Fuzzy Logic

The different «filtered» and smoothed signals are combined with fuzzy logic. A diagnosis is prepared automatically and on-line.

Principle of the fuzzy logic

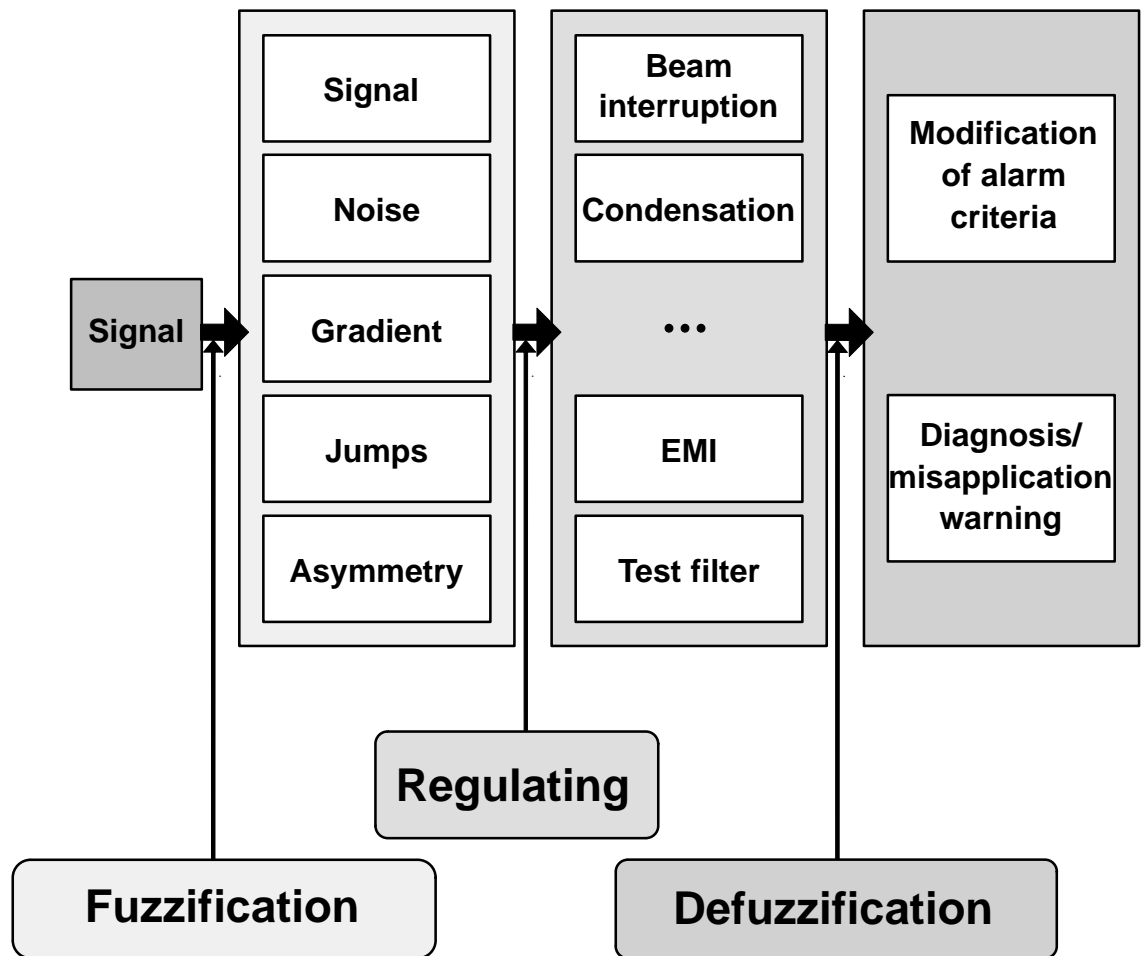

3.8.3 Possible diagnosis results

1. Fire

The detector registered a signal which corresponded to a normal fire with the necessary extinction and activated an alarm.

If this turns out to be a false alarm, then most probably an aerosol was present in the room which simulated the development of a genuine fire and caused the necessary extinction.

Possible remedy: – Less sensitive setting

2. Slowly developing fire

The detector registered a signal which corresponded to a slowly developing fire and upon sufficient extinction activated an alarm.

In the event of a false alarm the diagnosis could point to possible condensation.

Possible remedy: – Install detector heating
– Less sensitive setting

3. Thermal turbulence / electromagnetic interference (EMI)

Thermal turbulence points to powerful air circulation. This is mainly caused by air heaters, baking ovens, furnaces etc.

Thermal turbulence and/or powerful electromagnetic interference generate “noise” which is filtered out by the algorithms. However, if it exceeds a certain strength and duration, it can still lead to detector impairment.

Possible remedy: – Remove detectors from such an environment.

4. Repeated interruption

Repeated interruption of the beam is caused by moving objects, such as cranes, ladders, decorations etc. or also by powerful electromagnetic interference which has an effect on the detector.

Normally, in time this leads to fault signals being activated, but also results in unwanted alarms.

Possible remedy: – **Such applications must be avoided**

5. Test filter

If the test filter is held in the infrared beam, it causes a sudden decrease in signal strength without however, reaching zero.

This characteristic causes the detector to activate an alarm after approx. 10s.

4 Planning

4.1 General project engineering principles

The linear smoke detector DLO1191 is due to its detection principle and its large monitoring surface for certain applications an attractive detector.

If local national regulations exist concerning application, have this priority!

4.2 Operating conditions

- The distance between DLO1191 and reflector must be between 5m and 100m.
- There must be a permanent, clear line of vision between detector and reflector.
 - The monitoring IR beam may not be interrupted by moving articles, e.g. overhead cranes, ladders, transportable articles, spiders' webs etc.
 - Turbidity of visibility caused by operations-related dust, steam or smoke development can impair the system.
- The mounting place of the detector must be statically absolutely stable, since the allowable deviation of the monitoring beam amounts to max 0,43° (see section 3.2).
 - Concrete and brick walls mostly fulfill these characteristics.
 - Pure wood and steel constructions are usually unsuitable, there temperature and humidity variations, wind or snow pressure influence such constructions.
- The monitoring beam must have free view at least 30cm on all sides, so that no unwanted reflections develop.
- Frontal incidence of sunlight, light from halogen lamps, etc. on the DLO1191 should be avoided if possible (to high temperature).
- For the service staff the detector must be at any time well accessible.
 - Cleaning and adjusting works are badly executable on ladders. Suitable equipment for this purpose includes fixed catwalks, platforms, "Skyworker" etc.
- The alarm activation of the DLO is based on the light attenuation caused by smoke (extinction). The accumulation of smoke in a fire is adequately dense usually only in the "smoke plume", in order to produce sufficient extinction for alarm activation.
 - For this reason always mount the DLO1191 in the vicinity of the ceiling (see Fig. 21 for distances). It must not be too close to or too far from the ceiling.
 - For very high rooms we recommend to arrange additional DLO1191 on different levels (see section 4.6.3) and/or additionally to install flame detectors.

If careful attention is not given to these points, the linear smoke detector system cannot function correctly and sometimes later leads to insoluble problems with unwanted activation of fault and alarm signals.

4.3 Fields of application

4.3.1 Examples of suitable fields of application

Basically whenever point type smoke detectors do not offer the best solution and where linear smoke detectors comply with the operating conditions in section 4.2 and thus have as regards application, installation and price.

Use	Reason
Buildings with ceilings of historical interest	Point type detectors on the ceiling unwanted Installation on the ceiling not possible
Atria (Malls), detection at different levels	Point type detectors due to height inaccessible and detection of smoldering fire is impossible
Large and high halls	Lower capital investment
Churches	No impairment of the ceiling by installation and point type detectors
Long corridors, cable and energy ducts with >3m room height	Lower capital investment
Aircraft hangars with sturdy building construction and flame detectors alone are insufficient	Lower capital investment
Sawtooth roofs, where point type detectors must be lower suspended	Lower capital investment

4.3.2 Examples of unsuitable fields of application

Use	Reason
Buildings of wooden or steel construction, without statically stable mounting surfaces	Insufficient building static, too large beam deviation caused by changing environmental influences
Low rooms or halls with crane tracks	Beam interruptions by moving persons or objects
Production rooms, garages with diesel engine vehicles	False alarms through accumulation of smoke, dust, steam etc.

4.4 Monitoring areas with flat ceilings

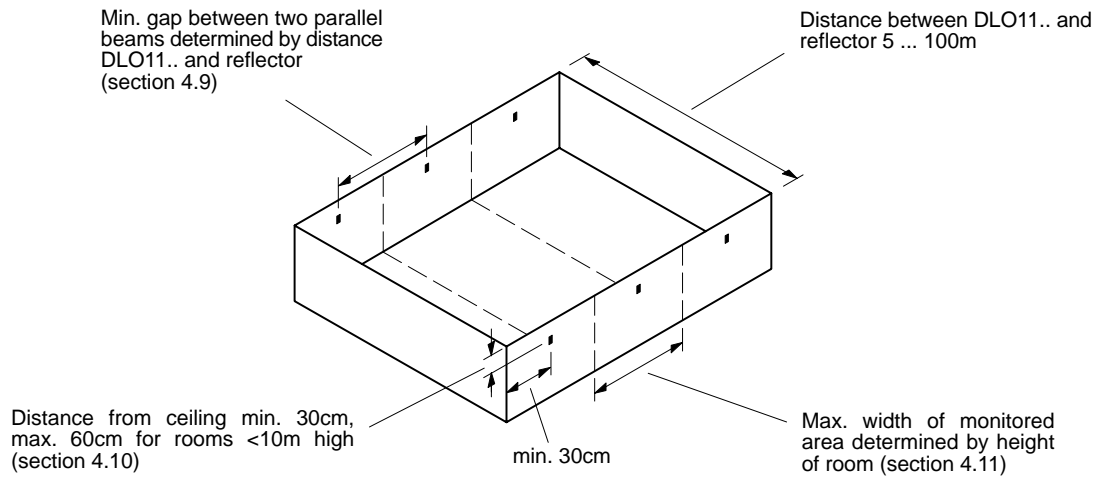

Fig. 11 Detector layout in areas with flat ceilings

4.5 Monitoring areas with sloping ceilings

To be defined as «sloping», a ceiling must have an angle of inclination of at least 11° which corresponds to 20cm/m. With gable roofs which have a slope of >0.5, always arrange a monitoring beam in the gable area.

Example:

Calculation of the slope n

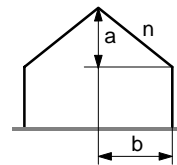

$$n = \frac{a}{b} \quad \left(\frac{4m}{10m} = 0,4 \right)$$

4.5.1 Additional DLO1191's on the slope of the ceiling

The number of DLO1191's required results from the maximum permissible monitoring width shown in section 4.11

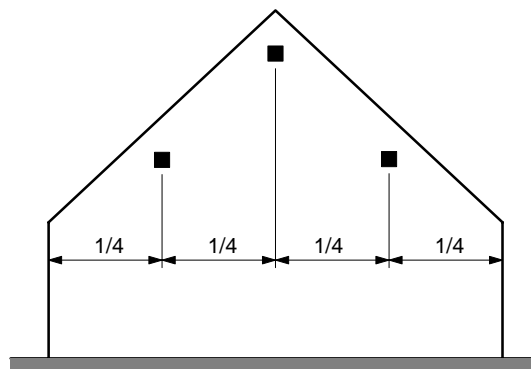

Fig. 12 Arrangement with 3 monitoring beams on a sloping ceiling

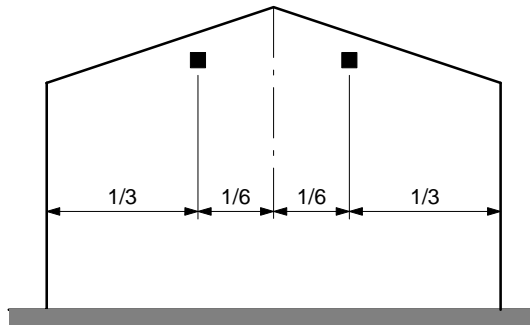

Fig. 13 If the ceiling slopes only slightly ($N < 0.5$), the monitoring beam in the gable is unnecessary

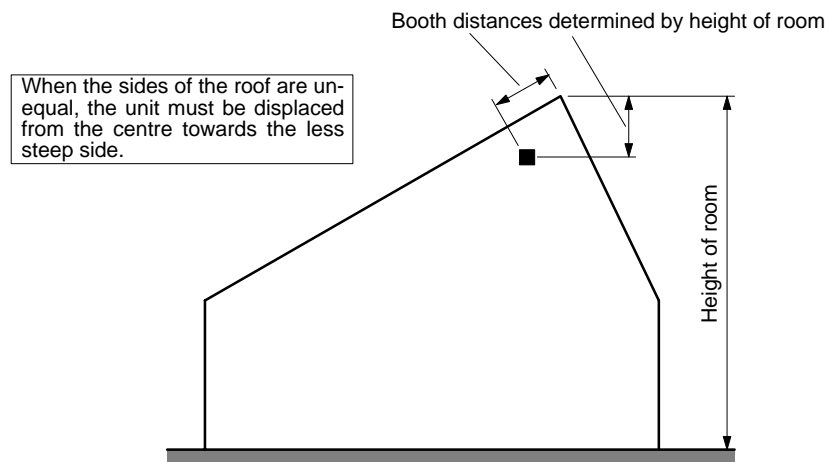

Fig. 14 Positioning underneath unequal sloping ceilings

With sloping ceilings the smoke is channelled into the gable, i.e. there is an increased smoke concentration in this area. Therefore, the monitoring width per DLO1191 can be increased according to section 4.11

4.6 Monitoring areas with joist constructions

Note that the term «joists» also covers such structures as air conditioning ducts which are mounted up to 0.15m below the ceiling.

In principle linear smoke detectors must be placed in the inter-joist area. Due to economic reasons this is not possible, layout underneath joist constructions is also permissible according to 4.6.1

4.6.1 Layout underneath joist construction

The linear smoke detector can be mounted below the joists, if:

- the joist height is **less than 20%** of the total height of the room
- If the width of the inter-joist area is $\leq 50\%$ of the maximum broad of surveillance
- or if the inter-joist area is $\leq 200\text{m}^2$

When calculating the width of the monitored area that only the distance up to the joist construction counts as the height of the room h .

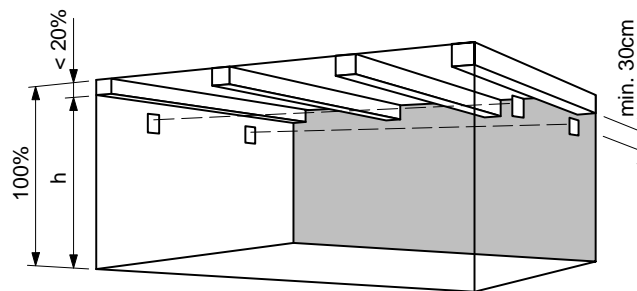

h : Height for determining max. width of monitored area

Fig. 15 Detector layout underneath joist construction

4.6.2 Layout within the joist area

When the joist construction is **more than 20%** of the total height of the room, than the joists must be considered as room dividers and each section must be individually monitored.

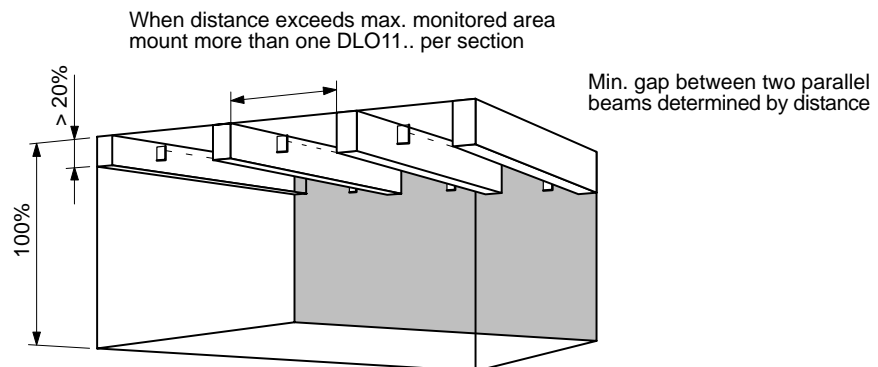

Fig. 16 Detector layout within joist construction

4.6.3 Detection of smouldering fire in high rooms

In order that smouldering fires or smaller fires with weak thermal current can be detected even in high rooms, a second or a third IR beam must be arranged at the assumed height of the spread of smoke of a smouldering fire. This application can be useful for rooms >6m in height.



Fig. 17 Detection of smouldering fires in high rooms on different levels

Examples:

Room height (highest level)	lowest level	intermediate level
6m	3 – 4m	–
12m	6 – 7m	–
20m	6 – 7m	~12m

4.7 Guideline for distances between DLO1191 and reflector

Distance DLO1191 → reflector	Types and number of reflectors
5 – 10m	Short distance filter + 1 DLR1193
10 – 30m	1 DLR1193
30 – 50m	1 DLR1192
50 – 65m	4 DLR1192
20 – 100m	1 DLR1191

If a number of reflectors are used they must be arranged close together and in the form of a square. Distances are approximate, i.e. they depend on detector and reflector tolerances and can easily vary by a few metres. The important thing is that sufficient signal strength is achieved.

4.8 Panes of glass

4.8.1 Penetration of panes of glass

With the reflector principle, the penetration of panes of glass is subject to certain restrictions.

1. Panes of glass must be absolutely smooth, clear and firmly installed.
2. Panes of glass must **never** be positioned at a right angle to the optical axis, in which the pane of glass has the effect of a mirror and can reflect the beam back to the receiver (angle of incidence = angle of reflection).
3. As much as possible penetrate only one pane of glass. Maximum 2 panes of 5mm glass may be penetrated.
4. Each pane of glass reduces the distance by 20m.
5. The detection is certain, if the signal decreases to <2 when the reflector is covered (see section 6.3 electronic alignment).

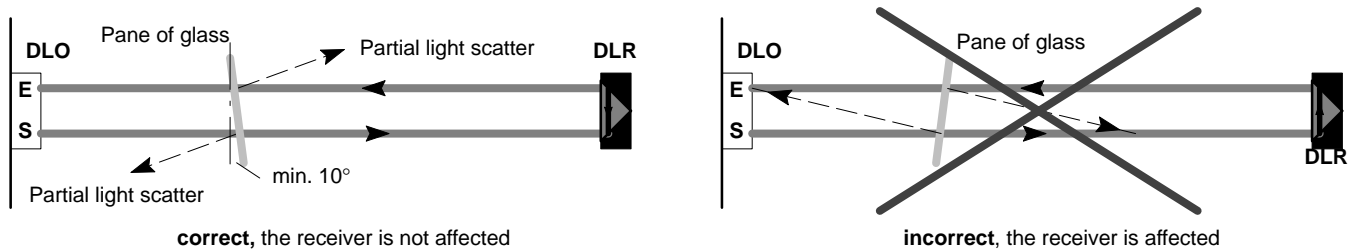

Fig. 18 With the penetration of panes of glass, check the angle in relation to the optical axis

4.8.2 Application example

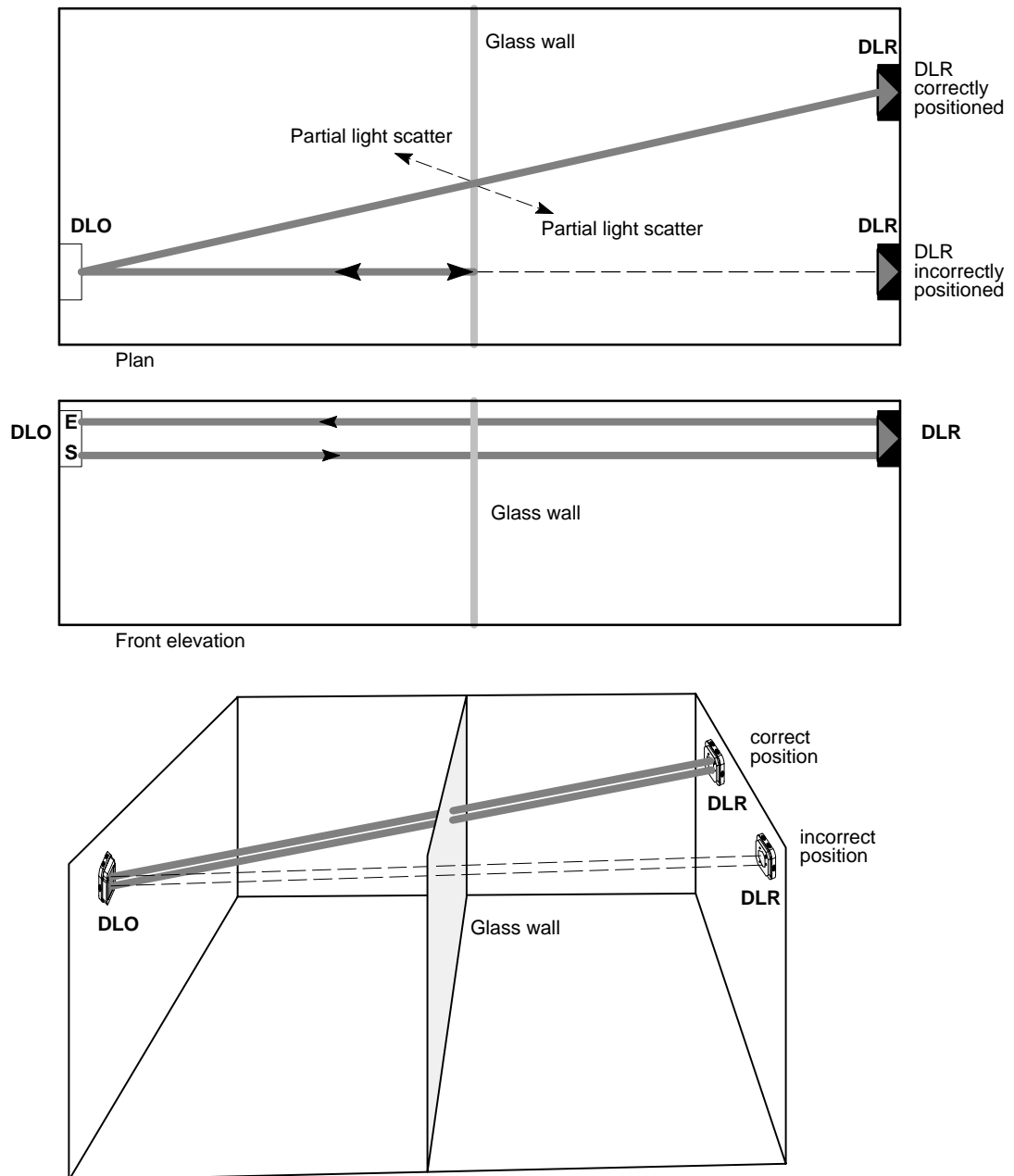

Fig. 19 Application example for the penetration of panes of glass

4.8.3 Reflectors mounted on glass walls

If reflectors are mounted on glass walls, there is a danger that the glass and not the reflector will reflect the beam. This situation may only occur after commissioning if the glass wall moves slightly. However, it does not occur if the beam strikes a glass wall at an angle greater or less than 90° .

Recommendation: In such cases hit the beam in a light angle of $5^\circ - 10^\circ$ to the reflector, in order that such reflections which cause interference can be avoided.

4.9 Minimum distances between two pairs of detectors

The monitoring beam must not be mounted closer than 30cm to the ceiling, walls, installations and stored material.

In order to prevent the mutual interference of two or more DLO1191 detectors where there is an increasing distance between DLO1191 and reflector, maintain an ever-increasing transverse distance between DLO1191 and reflector:

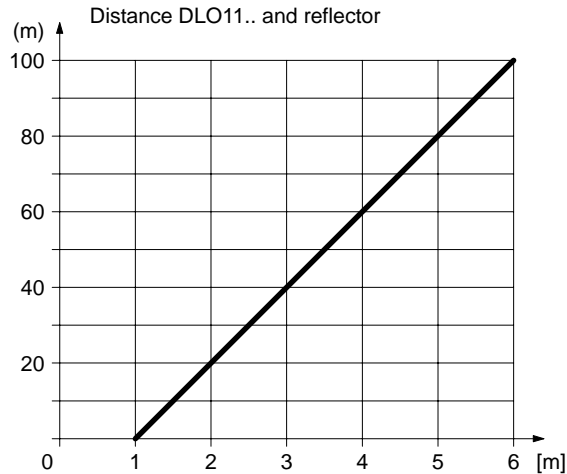

Fig. 20 Min. distance between two parallel IR beams

4.10 Beam spacing from the ceiling

In order that the IR beam can detect the smoke, it is normally mounted immediately beneath the cushion of warm air. The higher the room, the further away the DLO1191 and the reflector should be mounted from the ceiling.

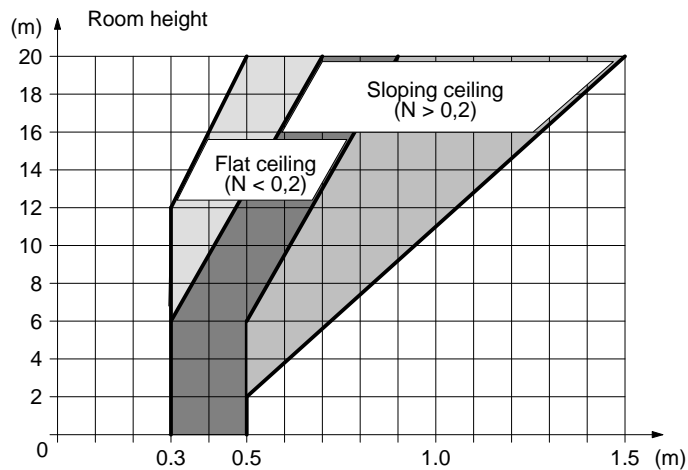

Fig. 21 Distance from IR beam \Rightarrow ceiling

– The steeper the gable roof, the greater the distance must be between the IR beam in the gable and the ridge.

4.11 Maximum monitoring width

The monitoring width can be increased with increasing room height.

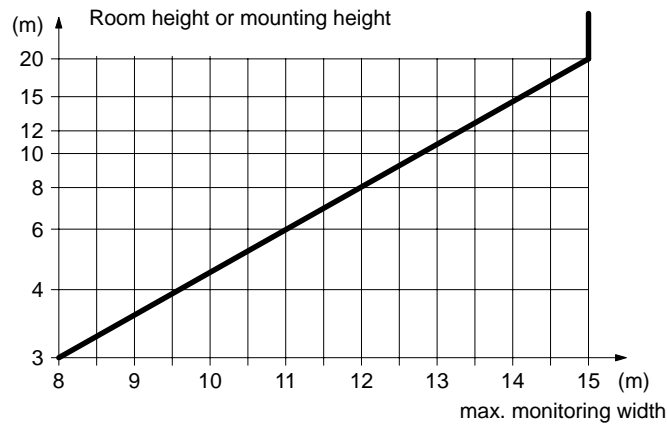
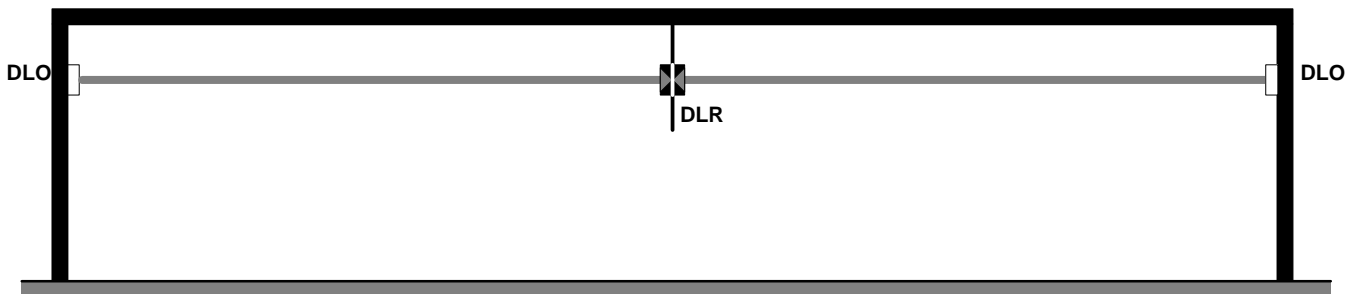

Fig. 22 Monitoring width dependent on the room height

If the monitoring beam is set at a low level in order to detect smouldering fire, then instead of room height the distance between floor and detector applies. However, to cover increased risks a narrower monitoring width can be chosen.

4.12 Measures for dividing long distances



DLO1191s can negatively influence each other if mounted face-to-face. In such an arrangement a sufficiently large plate must be mounted between the reflectors.

4.13 Measures against condensation

If the DLO1191 or the reflector is mounted on cool outside walls, in rooms in which high humidity and rapid increase in temperature (e.g. sunshine on non-insulated roof) are to be expected, the detector heating unit DLH1191 must be used to prevent. Condensation of the front cover cause trouble or false alarms. For this application and for short distances, use the reflector DLR1191 with built-in heating.

4.14 Installation locations

When installation locations are rigid and vibration-free even a large temperature fluctuation (e.g. between day and night) has only slight influence on steel girders and therefore does not greatly alter the structure of a building. However, if the installation location is not rigid, the closely bundled infrared beam can quickly wander from the receiver and so cause an alarm or trouble signal. Unstable installation locations include:

- the walls of rooms constructed of steel which expand and contract due to the temperature coefficient of steel
- masonry walls on which a steel roof has been constructed

In such cases the DLO1191 must be mounted on the rigid structural element, meanwhile the reflector can be mounted on the instable wall.

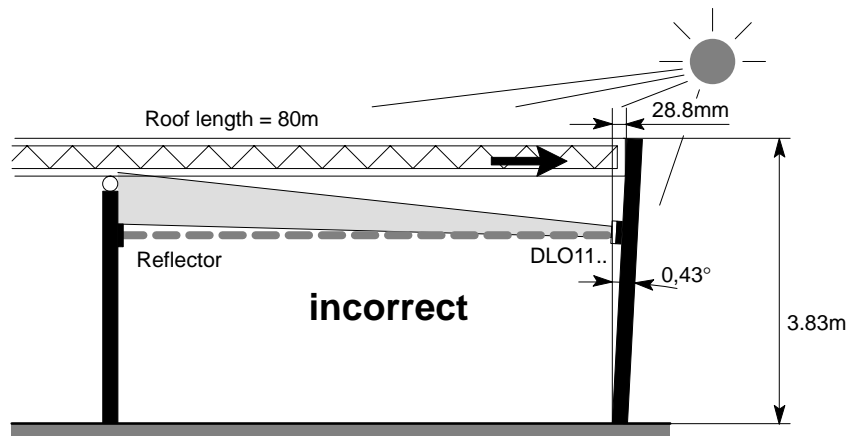

Fig. 23 Deflection of the IR beam caused by heat on the steel roof

The linear expansion of steel:

$$l \text{ (mm)} \times \Delta T \text{ (}^\circ\text{C)} \times \text{linear coefficient of expansion (0.000012)} = \text{mm}$$

Example:

$$80,000 \times 30 \times 0.000012 = 28.8\text{mm}$$

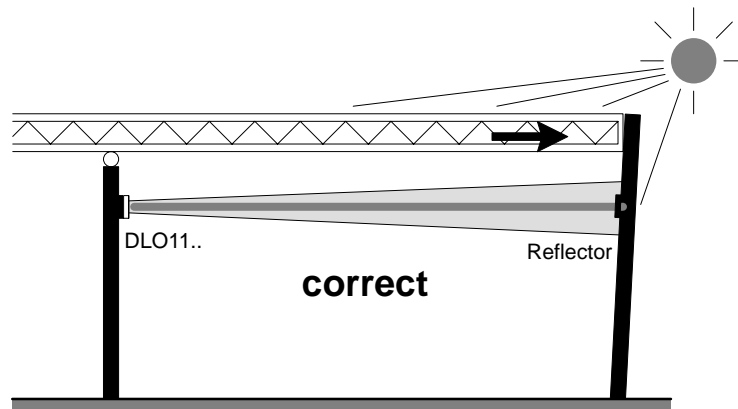

Fig. 24 Possible solution by mounting of the DLO1191 on the stable surface and mounting of the reflector on the instable wall

4.15 Accessibility

The DLO1191 must always be easily accessible also in high halls for commissioning and servicing. Suitable equipment for this purpose includes fixed ladders, catwalks, etc. or safe mobile equipment such as stacker trucks, sky-workers etc.

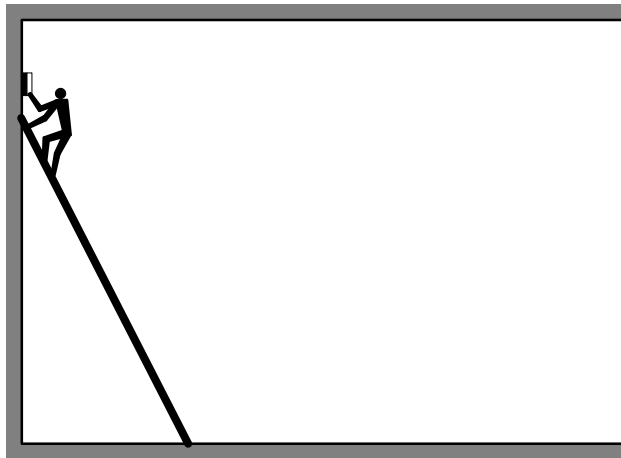

Fig. 25 Difficult and dangerous work using a ladder

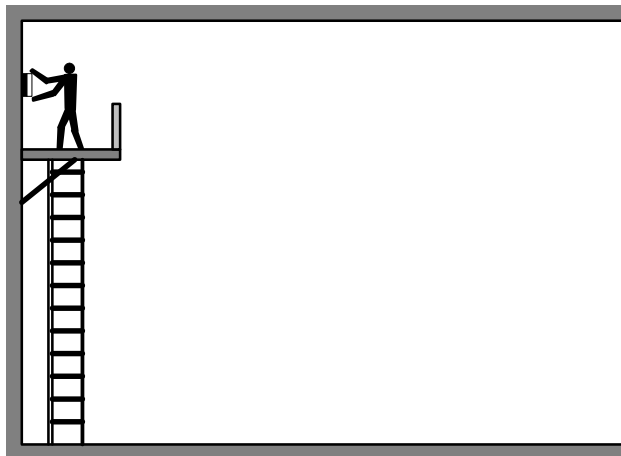

Fig. 26 Precise and safe work using a permanent platform

5 Installation

5.1 Mounting

- Surface mounting directly on the wall (minimum clearance to ceiling and other obstacles at least 30 cm)

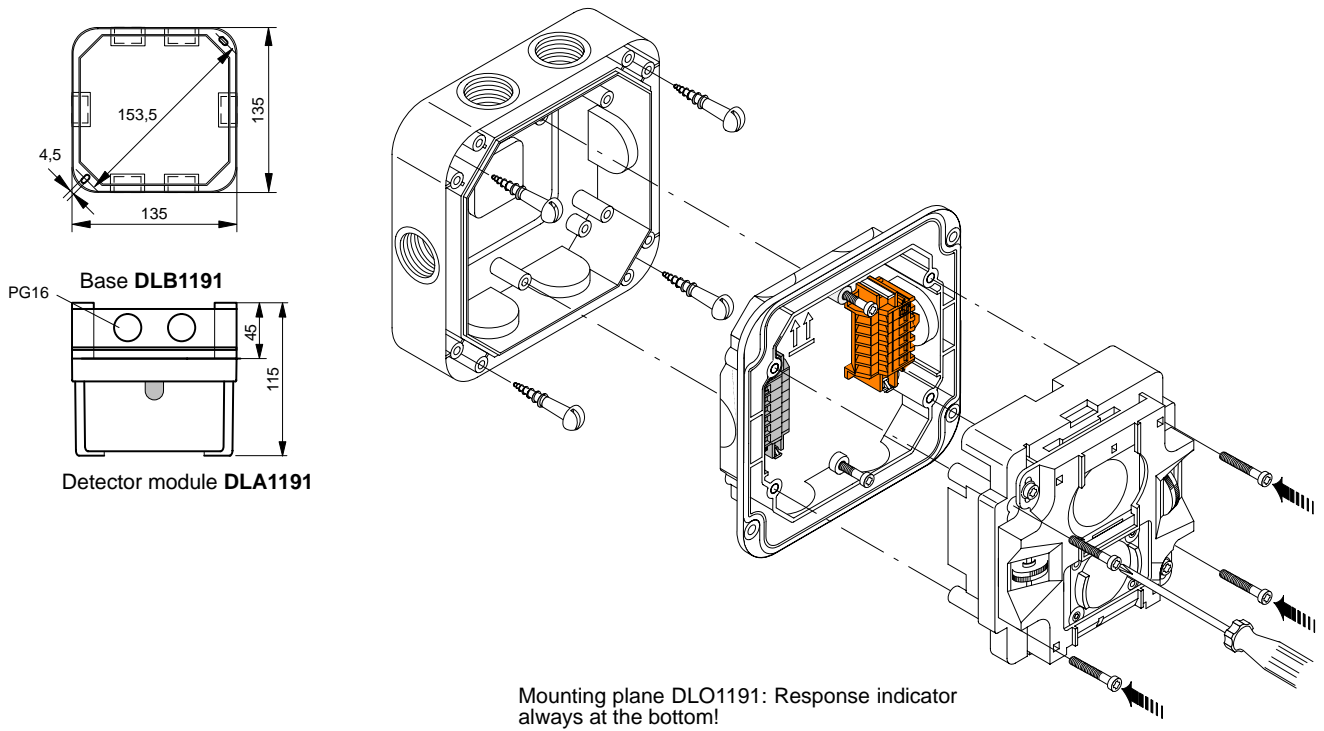

Fig. 27 Installation of the DLO1191

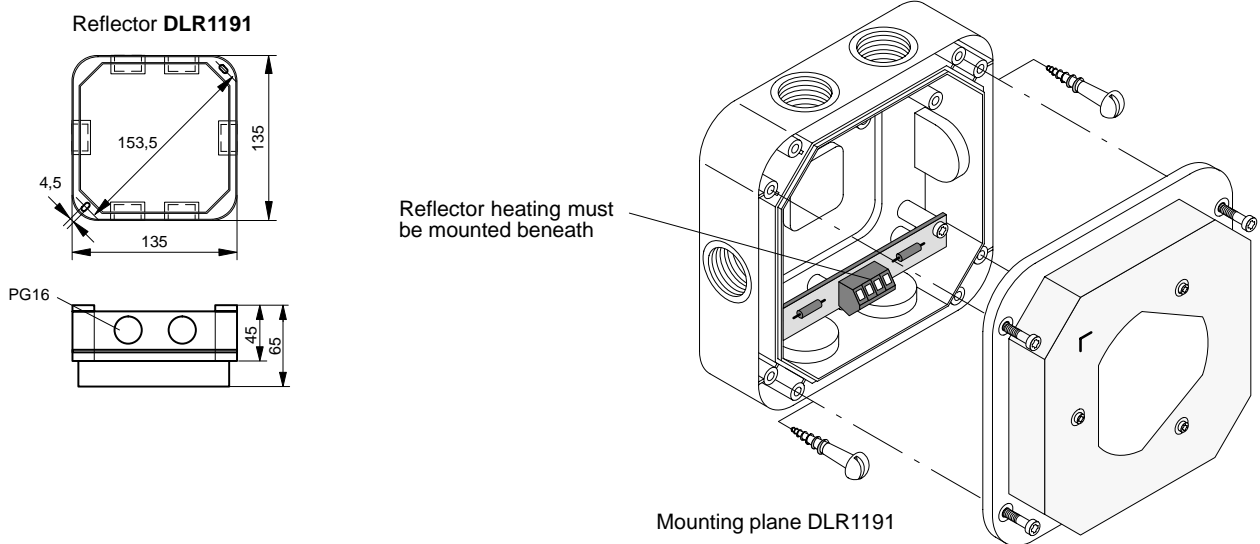

Fig. 28 Installation of the DLR1191 reflector

5.2 Wiring

The detector is installed with a twisted 2-wire line from base to base. Ring and stub lines are admissible.

The DLB1191 base contains a terminal block with 6 terminals for connecting the detector to the line and for connecting the external response indicator.

5.2.1 Special filter

For distances $\leq 10\text{m}$ insert the corresponding short distance filter (7–10m DLF1191-AA, 5–8m DLF1191-AB).

In the event of influence from external light, insert the corresponding filter (DLF1191-AC) (not possible, if short distance filter is inserted).

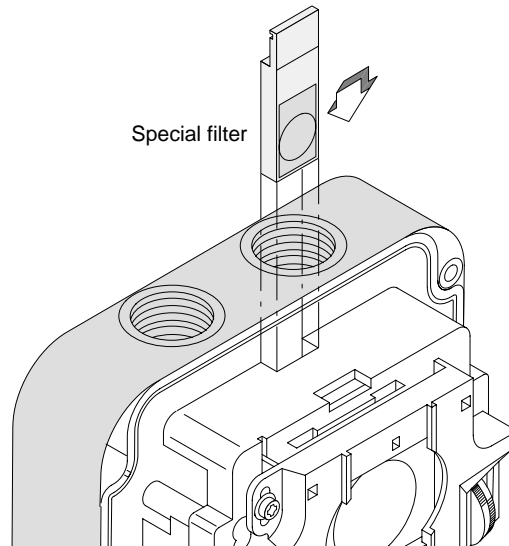

Fig. 29 Insertion of special filter

5.2.2 Detector heater

In the event of danger of condensation the installation of the detector heater is recommended (Note: Supply voltage 24V necessary).

A terminal block is supplied together with the detector heater for connecting the detector heater and is latched in the base opposite the terminal block.

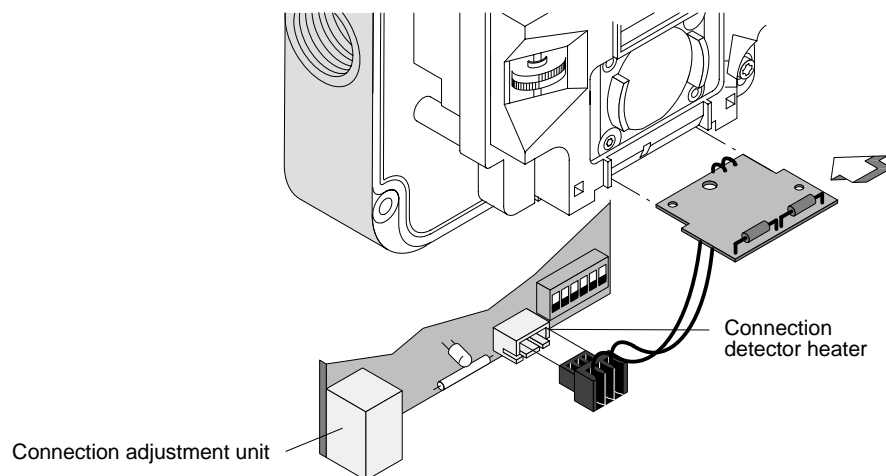

Fig. 30 Connection of the detector heater

5.3 Interactive mode

In interactive mode the number of linear smoke detectors is limited.
 Connection factor **IMK = 10** for one DLO11911

5.4 Collective mode

In collective mode only **one** detector may be connected to a detector line.
 Connection factor **KMK = 25**

5.5 Connection

Connection diagram interactive mode

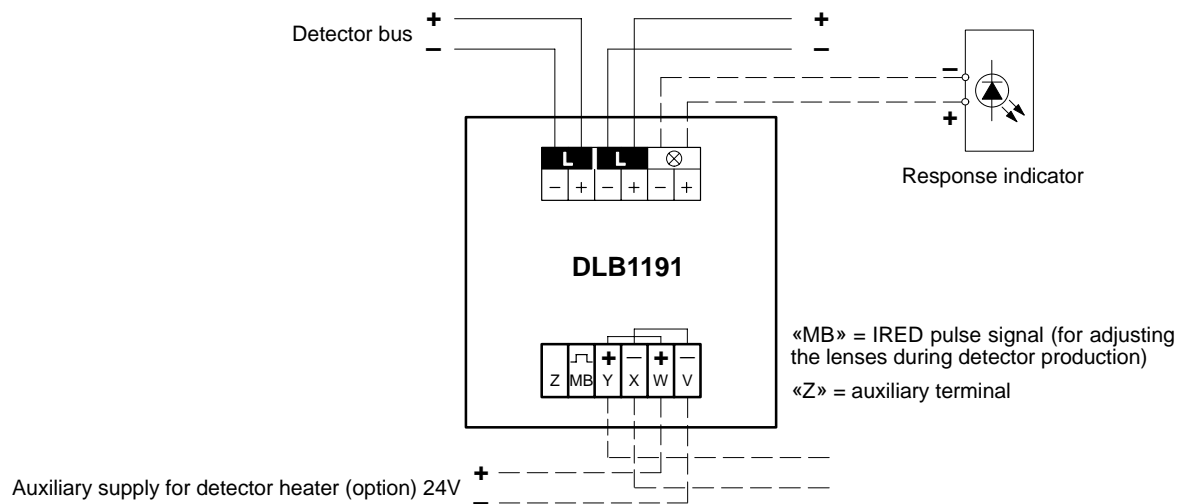

Fig. 31 Connection diagram for interactive mode

Connection diagram collective mode

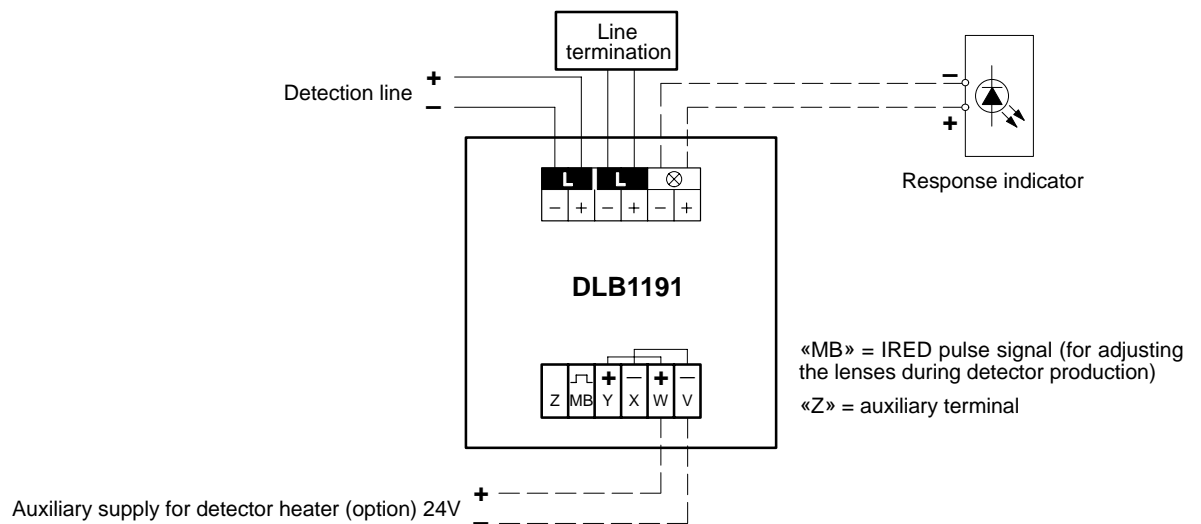

Fig. 32 Connection diagram for collective mode

6 Commissioning

6.1 Settings

- Remove the detector cover
- Set the DIP switches

The DLO1191 can be operated either on an interactive DS11 line or a collective line. The choice between collective and interactive line is made with DIP switch **[S4]**.

The detector has 3 sensitivity settings («Reduced», «Standard», «Increased»). The response threshold is set with DIP switch **[S1]**, **[S2]**.

The transmitter intensity (strong, weak) can be set with DIP switch **[S3]**.

The DIP switch [S3] which governs the transmitter intensity is set to «strong» by default. If the signal amplitude is too high (display on the adjustment unit: Range = 13, signal > 50), the transmitter can be set to «weak». If the measurement section is ≤10m, a supplementary filter must be installed.

Function	S1	S2	S3	S4	S5	S6
Reduced sensitivity	<input type="checkbox"/> OFF	<input checked="" type="checkbox"/> ON				
Standard sensitivity	<input checked="" type="checkbox"/> ON <input type="checkbox"/> OFF	<input checked="" type="checkbox"/> ON <input type="checkbox"/> OFF				
Increased sensitivity	<input checked="" type="checkbox"/> ON <input type="checkbox"/> OFF	<input type="checkbox"/> <input checked="" type="checkbox"/> OFF				
Weak transmitter signal			<input checked="" type="checkbox"/> ON <input type="checkbox"/> OFF			
Strong transmitter signal			<input type="checkbox"/> <input checked="" type="checkbox"/> OFF			
Collective system				<input checked="" type="checkbox"/> ON <input type="checkbox"/> OFF		
Interactive system				<input type="checkbox"/> <input checked="" type="checkbox"/> OFF		
Reserve					<input checked="" type="checkbox"/> ON <input type="checkbox"/> OFF	
«S6 ON» Alarm at beam interruption (< 60s)						<input checked="" type="checkbox"/> ON <input type="checkbox"/> OFF
«S6 OFF» Fault at beam interruption (< 30s)						<input type="checkbox"/> <input checked="" type="checkbox"/> OFF

* Operating conditions according to BS 5839: Part 5

Fig. 33 Settings

6.2 Mechanical adjustment

- Install the alignment device on the detector.
The mirror with backsight and the foresight must be firmly mounted to be free from play!
- Unfasten the locking screw.
- Align the detector lens to the reflector.
The detector lens can be adjusted with the knurled screws.
Rough adjustment via backsight and foresight so that the target (reflector) and the foresight opening are aligned with the reticule. Attaching a pocket torch to the reflector side or illuminating the reflector with a spotlight simplifies the rough adjustment procedure.
- Switch on the detection line.
- Connect the adjustment unit to the detector.
Attention: At first use insert a new battery!
Switch the adjustment unit to «ON» and «AUTO-RANGE». The correct range will be measured automatically.
When the mechanical adjustment is correct, a signal > 2 should be available on the adjustment unit. This signal changes strongly when the knurled screw is turned.
- Remove the aiming device.

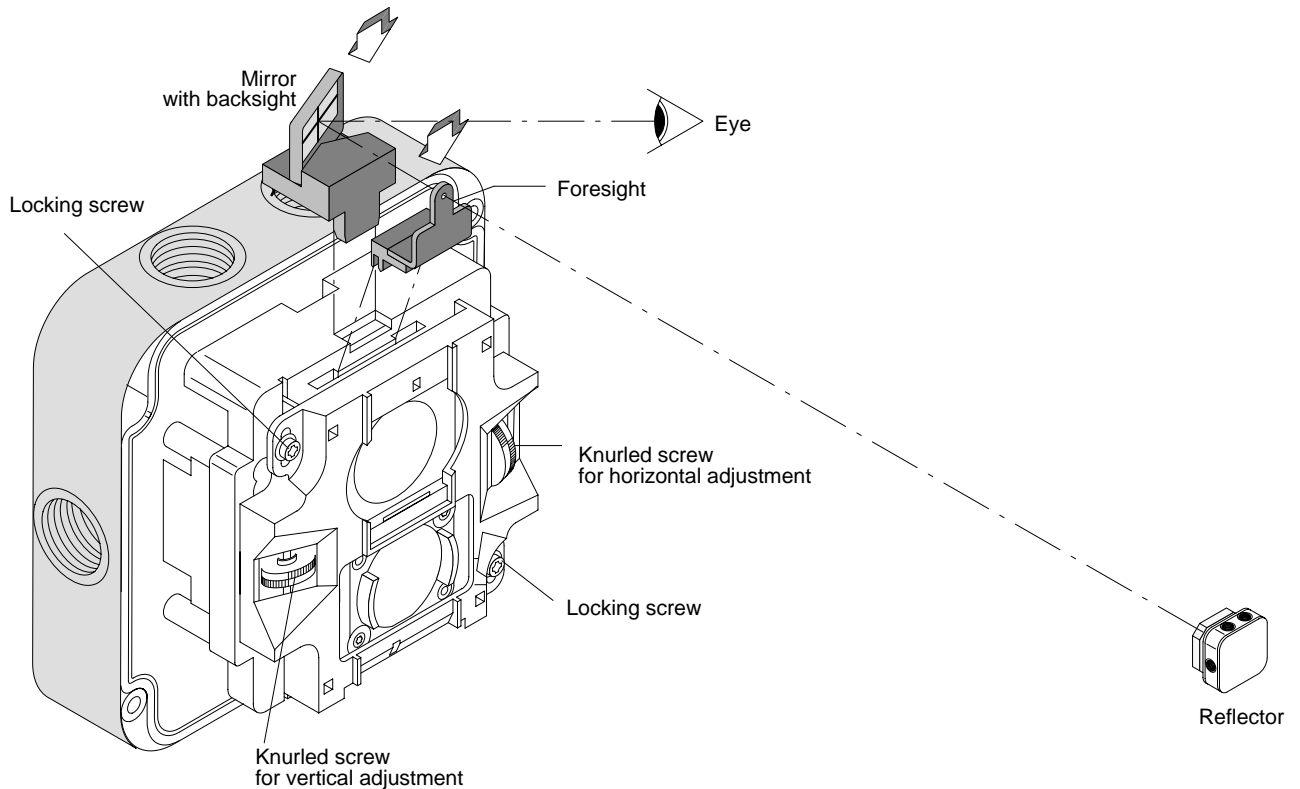

Fig. 34 Mount the aiming device and align the detector to the reflector

6.3 Electronic alignment

- Switch to «AUTO-RANGE».
- With the knurled screws fine-adjust the detector lens to the maximum signal (adjustment set display switched to «RANGE»).
- The knurled screws should be turned slowly in order to avoid large signal jumps.
- When the maximum value is obtained (must be between min. 4 and max. 13), switch to «FIX-RANGE» and adjust to the maximum value «SIGNAL». Caution! If the signal value is >60 , switch back to «AUTO-RANGE» in order to adjust the range, and then re-adjust to the maximum value «SIGNAL».
- The «RANGE» and «SIGNAL» indication on the adjustment device should both be attain a maximum value. If «Range» is 13 and «Signal» ≥ 60 , the transmitter signal (switch S3) must be set to weak.
- Engage the locking screws.
- Switch the adjustment set to «FIX-RANGE».
- **Cover the reflector.**
- With a dark cover interrupt the IR beam: the signal should decrease to <2 . If this is not the case the detector has not been aligned correctly to the reflector but to reflecting obstacles in the environment of the measurement section. Repeat the adjustment procedure!
- Disconnect the adjustment set from the detector.
- Reinstall the detector cover.

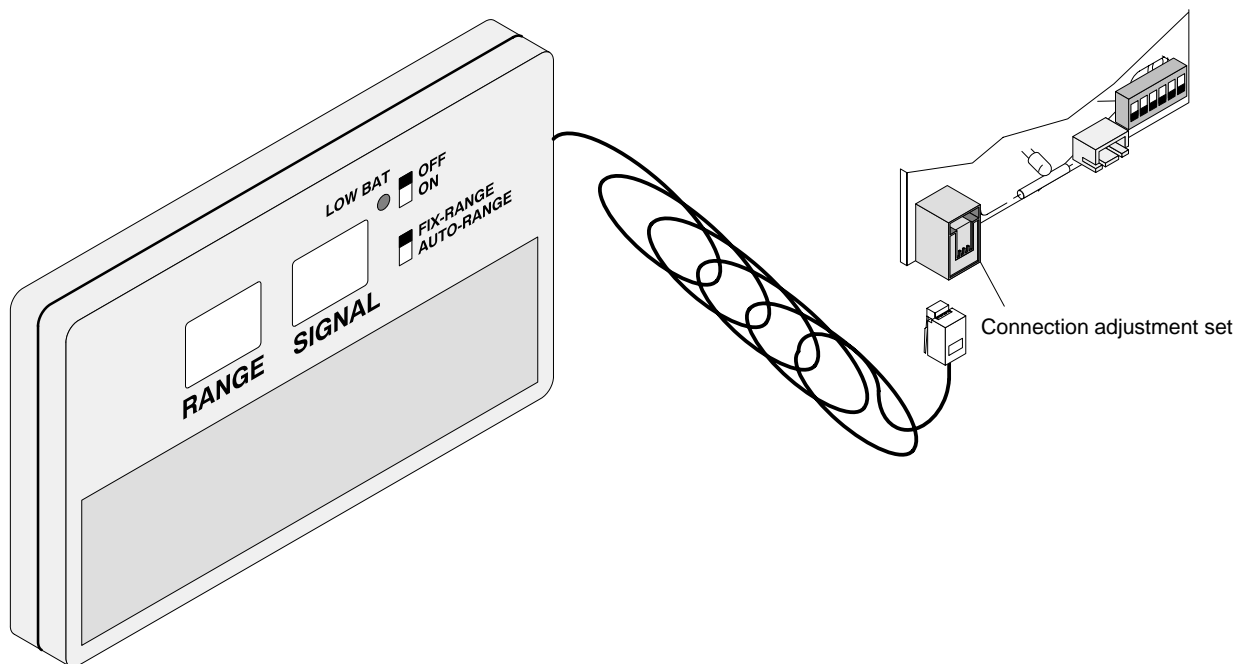

Fig. 35 Adjustment set

6.4 Initialization

- To initialize the detector, a reed relay located near the internal response indicator (A) is activated with a magnet. The initialization is signalled with a flashing response indicator.

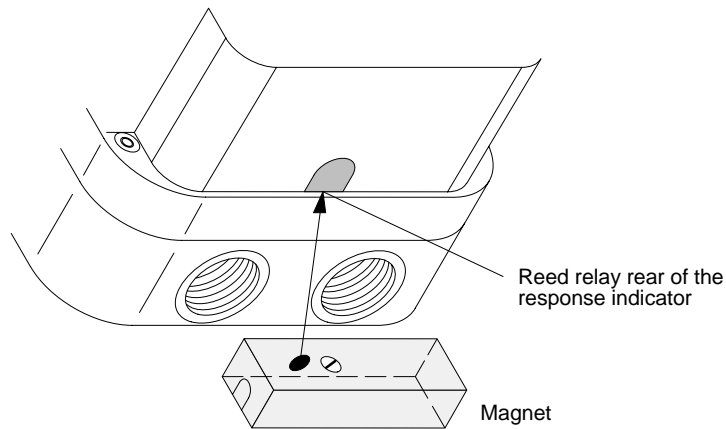

Fig. 36 Initialization with the magnet

During the initialization the working range of the electronics («RANGE»), the compensation value, all smoothing algorithms and diagnostics, and the status are set to an initial value. All required thresholds are calculated. At the same time a self-test is performed.

- Initialization with the magnet.
Place the magnet directly behind the response indicator (AI) in order to activate the Reed relay (Attention! Black point = magnet).
As soon as the response indicator flashes, the compensation value is formed (approx. 30 sec.). During this time the measurement should not be interfered with: No manipulations on the detector and no interruption of the IR beam.
When the initialization is completed, the AI turns off. If any procedural error has been made, a new initialization can be started at any time with the magnet.
- Test alarm with test filter.
Place the test filter immediately in front of the detector and cover the entire measurement window. When an alarm is triggered, the response indicator flashes after approx. 5 seconds (interactive), or after approx. 10 seconds (collective).
- The commissioning is now completed.

6.5 Addressing in the interactive system

- The addressing is the same as in stationary equipment. The addresses of the individual detectors are assigned in the sequence in which each detector is set into alarm condition. But first the control unit must be switched to «Address distribution mode».
- A test alarm can also be combined with the addressing.

7 Faults / overhaul

7.1 Fault

If the detector is removed a fault is triggered (detection line interruption). Close the detector monitoring contact in the base of the interactive system.

- Too powerful a signal: «RANGE» 13, Signal ≥ 60 : **Set switch S3 to weak.**
- Too weak a signal: «RANGE» 4, Signal ≤ 50 : **Set switch S3 to strong or enlarge the reflector dimension.**

7.1.1 Interruption to beam

An interruption to the beam can be evaluated as an alarm or a fault depending on the S6 Dip-switch setting.

If it is evaluated as a fault, this function can be correctly tested by covering the reflector with non-reflective material. When covering the reflector, depending on the material used, reflections of up to approx. 10m can still cause an alarm by the material reflecting a weakened signal to the receiver.

Interruptions of the beam by moving objects are to be avoided. These can lead to inadvertent alarms or disturbances.

7.2 Reflection

If a specular surface comes too close to the measurement section or near the detector, a reflection can occur. Reflections can lead to an amplified signal.

This can cause unwanted faults with both systems (interactive, collective).

7.3 Checklist for trouble-shooting

- Is the building structure stable?
- Is the detector solidly mounted and are all screws tightened?
- Is the correct type of reflector installed?
- Are the Dip switches S1 – S6 set correctly?
- Is the correct voltage connected to the detector
- Are the range and signal really adjusted to the absolute maximum?
- Does the signal fall to 0 if the **reflector** is covered?
- Was the detector initialized after adjustment with cover mounted?
- Is the beam sometimes interrupted by obstacles (crane, decorations, spiders' webs etc.)
- Is the beam sometimes subject to mist, steam or dust?
- Is there danger of condensation?
- Does the sun or another powerful light source impinge on the detector direct?
- Do radiators have an influence on the beam (thermal turbulence)?

7.4 Functional check / overhaul

The detector self-test subjects the DLO1191 automatically to an extensive electronic functional check. Nevertheless it is necessary to physically check the functions on site in regular intervals by triggering the detector with a suitable test filter (usually once per year). Detectors that do not respond or which are mechanically damaged must be replaced.

If an information or fault signal is transmitted during operation, the status bits in the EEPROM of the detector can be read out with the service computer. A preliminary diagnosis on the cause can be established based on this information.

All detector hoods and reflectors should be cleaned regularly with a soft piece of cloth which is either dry or soaked with Plexiklar, or a mild soap solution, depending on the environmental conditions and severity of contamination at the installation site. Do not use any solvents or steam jets.

8 Terminology

AlgoLogic	Protected trade-mark (Algorithm + Logic)
Algorithm	Special calculation method in the detector processor for optimizing the smoke sensitivity, noise immunity, and operational reliability
BS	British Standard
CC11	AlgoControl fire detection system control unit for the S11 fire detection system
DIP switch	Microswitch
DLO1191	Linear smoke detector
EEPROM	Electrically Erasable and Programmable Read Only Memory
EMC	Electro Magnetic Compatibility
EMI	Electro Magnetic Influence
FET	Field Effect Transistor
Fuzzy logic	Imprecise logic
IMK	Load factor for interactive elements
IR	Infrared
IREM	Infra-Red Emitting Diode
KMK	Load factor for collective elements
NFW	Compensation value (reference variable)
μp	Microprocessor
Range	Working range of the electronics
S11	Fire detection system S11

Siemens Building Technologies AG
Cerberus Division
CH-8708 Männedorf
Alte Landstrasse 411
Tel. +41 1 - 922 61 11
Fax +41 1 - 922 64 50
www.cerberus.ch

