

# Instrument Transformers Application Guide

**Edited by**

ABB AB

High Voltage Products

Department: Marketing & Sales

Text: Knut Sjövall, ABB

Layout, 3D and images: Mats Findell, ABB

SE-771 80 LUDVIKA, Sweden

# Instrument Transformers

## Application Guide

# Table of contents

<b>1. General principles of measuring current and voltage</b>	<b>8</b>
1.1 Instrument Transformers	8
1.2 Current transformers operating principles	8
1.2.1 Measuring errors	9
1.2.2 Calculation of errors	11
1.2.3 Variation of errors with current	13
1.2.4 Saturation factor	14
1.2.5 Core dimensions	15
1.3 Voltage transformers operating principles	16
1.3.1 Measuring errors	16
1.3.2 Determination of errors	18
1.3.3 Calculation of the short-circuit impedance $Z_k$	20
1.3.4 Variation of errors with voltage	21
1.3.5 Winding dimensions	22
1.3.6 Accuracy and burden capability	23
1.4 Capacitor Voltage Transformer (CVT)	23
1.4.1 Characteristics of a CVT	24
1.4.2 The CVT at no-load	26
1.4.3 The CVT at load	27
1.4.4 Calculation of internal resistance and loadpoint for other burden than rated	28
1.4.5 Inclination of the load line	30
1.4.6 Frequency dependence of a CVT	30
1.4.7 Error changes for voltage variations	31
1.4.8 Different power factor of the burden	31
1.4.9 Error variation for temperature changes	31
1.4.10 Quality factor	33
1.4.11 Leakage currents and stray capacitance	34
1.4.12 Transient behaviour	34
1.4.13 Transient response	34
1.4.14 Ferro-resonance	35
<b>2. How to specify current transformers</b>	<b>36</b>
2.1 Rated insulation level	36
2.2 Rated primary current	38
2.3 Rated continuous thermal current	40
2.4 Rated secondary current	40
2.5 Short-time thermal current ( $I_{th}$ ) and dynamic current ( $I_{dyn}$ )	40
2.6 Burden and accuracy	42
2.6.1 Measurement of current	42
2.6.2 Metering cores	42
2.6.3 Relay cores	45
2.6.4 Exciting curve	46
2.6.5 Accuracy classes according to IEC 60044-1	48
2.6.6 Accuracy classes according to IEEE C57.13	50
2.7 Pollution levels	52

### 3. Measurement of current during transient conditions 53

3.1	Background	53
3.2	The network	53
3.3	Important parameters	55
3.3.1	Rated primary current ( $I_{pn}$ )	55
3.3.2	Rated secondary current ( $I_{sn}$ )	56
3.3.3	Rated primary symmetrical short-circuit current ( $I_{psc}$ )	56
3.3.4	Secondary burden ( $R_b$ )	56
3.3.5	Specified duty cycle (C-O and C-O-C-O)	56
3.3.6	Secondary-loop time constant ( $T_s$ )	57
3.3.7	Rated symmetrical short-circuit current factor ( $K_{ssc}$ )	57
3.3.8	Rated transient dimensioning factor ( $K_{td}$ )	58
3.3.9	Flux overcurrent factor ( $n_f$ )	58
3.3.10	Maximum instantaneous error	58
3.4	Air gapped cores	59
3.4.1	Remanent flux ( $\psi_r$ )	59
3.4.2	Remanence factor ( $K_r$ )	59
3.5	Accuracy classes for transient cores according to IEC 60044-6	60
3.5.1	Error limits for TPX, TPY and TPZ current transformers	60
3.5.2	Error limits for TPS current transformers	61
3.6	How to specify current transformers for transient performance	61

### 4. How to specify voltage transformers 63

4.1	Type of voltage transformer	63
4.2	Rated insulation level	64
4.2.1	Rated insulation levels according to IEC	64
4.2.2	Basic insulation levels according to IEEE/ANSI	65
4.3	Rated primary and secondary voltage	65
4.4	Rated voltage factor	66
4.5	Burdens and accuracy classes	66
4.6	Pollution levels	69
4.7	Transient response for capacitor voltage transformers	69
4.8	Transient response for inductive voltage transformers	71
4.9	Ferroresonance	71
4.10	Ferroresonance in capacitor voltage transformers	71
4.11	Ferroresonance in inductive voltage transformers	72
4.12	Fuses	73
4.13	Voltage drops in the secondary circuits	73
4.14	Coupling capacitors	74
4.15	CVTs as coupling capacitors	74
4.16	Measure harmonics with CVTs	75

### 5. Design of current transformers 77

5.1	General	77
5.2	Hair-pin type (Tank type)	78
5.3	Cascade/Eye-bolt type	79
5.4	Top core type	79

# Table of contents

5.5	Combined current-voltage type	80
5.6	Mechanical stress on current transformers	81
5.6.1	Forces in the primary terminals	81
5.6.2	Wind load	81
5.6.3	Seismic withstand	82
<b>6. Design of inductive voltage transformers</b>		<b>83</b>
6.1	Mechanical stress on inductive voltage transformers	83
<b>7. Design of capacitor voltage transformers</b>		<b>84</b>
7.1	External disturbances on capacitor voltage transformers	85
7.2	Mechanical stress on capacitor voltage transformers	86
7.3	Seismic properties of ABB's capacitor voltage transformers	88
<b>8. Instrument transformers in the system</b>		<b>89</b>
8.1	Terminal designations for current transformers	89
8.2	Secondary grounding of current transformers	90
8.3	Secondary grounding of voltage transformers	91
8.4	Connection to obtain the residual voltage	92
8.5	Fusing of voltage transformer secondary circuits	94
8.6	Location of current and voltage transformers in substations	94
8.6.1	Location of current transformers	96
8.6.2	Transformer and reactor bushing current transformers	97
8.6.3	Physical order of cores in a current transformer	97
8.6.4	Location of voltage transformers	98
<b>9. Protective relays</b>		<b>99</b>
9.1	Current transformer classification	99
9.2	Conditions	100
9.3	Fault current	100
9.4	Secondary wire resistance and additional load	101
9.5	General current transformer requirements	101
9.6	Rated equivalent secondary e.m.f. requirements	101
9.6.1	Line distance protection REL670 and REL650	102
9.6.2	Line differential protection RED670	103
9.6.2.1	Line differential function	103
9.6.2.2	Line distance function	104
9.6.3	Transformer protection RET670 and RET650	105
9.6.3.1	Transformer differential function	105
9.6.3.2	Restricted earth fault protection (low impedance differential)	106
9.6.4	Busbar protection REB670	109
9.6.4.1	Busbar differential function	109
9.6.4.2	Breaker failure protection	110
9.6.4.3	Non-directional instantaneous and definitive time, phase overcurrent protection	110
9.6.4.4	Non-directional inverse time delayed phase overcurrent protection	111
9.6.5	Bay control REC670 and REC650	112
9.6.5.1	Breaker failure protection	112
9.6.5.2	Non-directional instantaneous and definitive time, phase and residual overcurrent protection	112

9.6.5.3	Non-directional inverse time delayed phase and residual overcurrent protection	113
9.6.5.4	Directional phase and residual overcurrent protection	114
9.6.6	Line distance protection REL501, REL511, REL521, REL531	114
9.6.6.1	Line distance function	114
9.6.7	Line differential protection REL551 and REL561	115
9.6.7.1	Line differential function	115
9.6.7.2	Line distance function, additional for REL561	117
9.6.8	Transformer protection RET521 and transformer differential protection RADSB	118
9.6.9	Busbar protection RED521	119
9.6.10	High impedance differential protection RADHA	120
9.6.11	Pilot-wire differential relay RADHL	120
9.7	Current transformer requirements for CTs according to other standards	121
9.7.1	Current transformers according to IEC 60044-1, class P, PR	121
9.7.2	Current transformers according to IEC 60044-1 class PX, IEC 60044 class TPS (and old British Standard, class X)	121
9.7.3	Current transformers according to ANSI/IEEE	122
<b>10.</b>	<b>Optical current and voltage transducers</b>	<b>123</b>
10.1	Fiber Optic Current Sensor (FOCS)	123
10.2	MOCT – Technical description	125

# 1. General principles of measuring current and voltage

## 1.1 Instrument Transformers

The main tasks of instrument transformers are:

- To transform currents or voltages from a usually high value to a value easy to handle for relays and instruments.
- To insulate the metering circuit from the primary high voltage system.
- To provide possibilities of standardizing the instruments and relays to a few rated currents and voltages.

Instrument transformers are special types of transformers intended to measure currents and voltages. The common laws for transformers are valid.

### Current transformers

For a short-circuited transformer the following is valid:

$$I_1 \times N_1 = I_2 \times N_2$$

This equation gives current transformation in proportion to the primary and secondary turns.

A current transformer is ideally a short-circuited transformer where the secondary terminal voltage is zero and the magnetizing current is negligible.

### Voltage transformers

For a transformer in no load the following is valid:

$$\frac{E_1}{E_2} = \frac{N_1}{N_2}$$

This equation gives voltage transformation in proportion to the primary and secondary turns.

A voltage transformer is ideally a transformer under no-load conditions where the load current is zero and the voltage drop is only caused by the magnetizing current and is thus negligible.

## 1.2 Current transformers operating principles

A current transformer is, in many respects, different from other transformers. The primary is connected in series with the network, which means that the primary and secondary currents are stiff and completely unaffected by the secondary burden. The currents are the prime quantities and the voltage drops are only of interest regarding exciting current and measuring cores.



### 1.2.1 Measuring errors

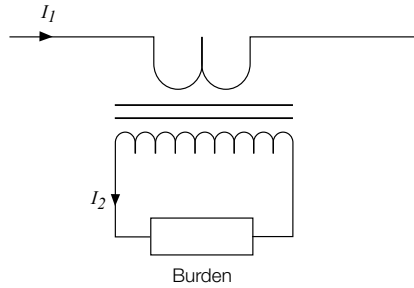

Figure 1.1

If the exciting current could be neglected the transformer should reproduce the primary current without errors and the following equation should apply to the primary and secondary currents:

$$I_2 = \frac{N_1}{N_2} \times I_1$$

In reality, however, it is not possible to neglect the exciting current.

Figure 1.2 shows a simplified equivalent current transformer diagram converted to the secondary side.

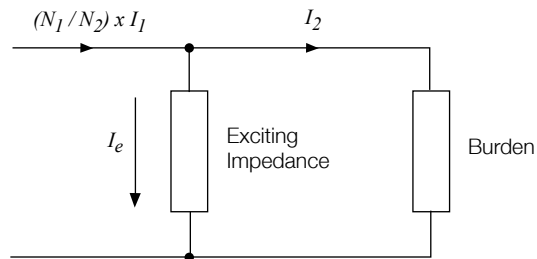

Figure 1.2

The diagram shows that not all the primary current passes through the secondary circuit. Part of it is consumed by the core, which means that the primary current is not reproduced exactly. The relation between the currents will in this case be:

$$I_2 = \frac{N_1}{N_2} \times I_1 - I_e$$

# 1. General principles of measuring current and voltage

The error in the reproduction will appear both in amplitude and phase. The error in amplitude is called current or ratio error and the error in phase is called phase error or phase displacement.

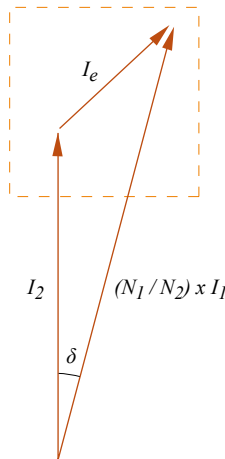

Figure 1.3

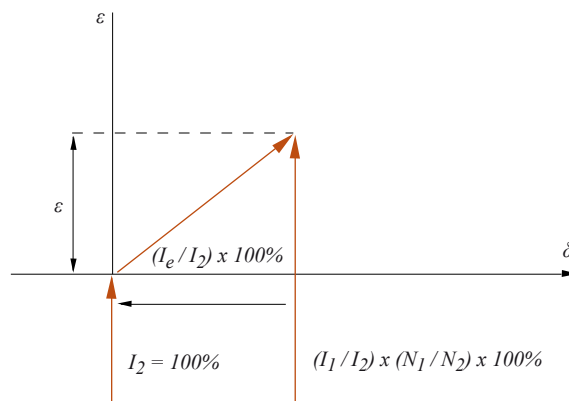

Figure 1.4

Figure 1.3 shows a vector representation of the three currents in the equivalent diagram. Figure 1.4 shows the area within the dashed lines on an enlarged scale.

In Figure 1.4 the secondary current has been chosen as the reference vector and given the dimension of 100%. Moreover, a system of coordinates with the axes divided into percent has been constructed with the origin of coordinates on the top of the reference vector. Since  $\delta$  is a very small angle, the current error  $\varepsilon$  and the phase error  $\delta$  could be directly read in percent on the axis ( $\delta = 1\% = 1$  centiradian = 34.4 minutes).

According to the definition, the current error is positive if the secondary current is too high, and the phase error is positive if the secondary current is leading the primary. Consequently, in Figure 1.4, the positive direction will be downwards on the  $\varepsilon$  axis and to the right on the  $\delta$  axis.

### 1.2.2 Calculation of errors

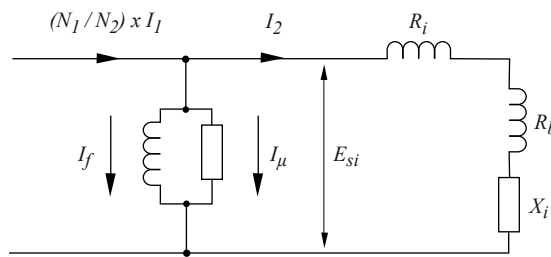

Figure 1.5

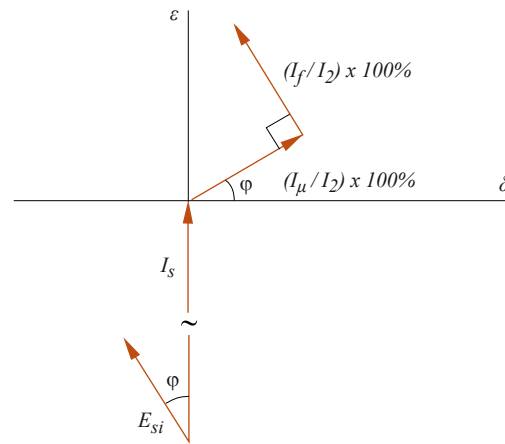

Figure 1.6

The equivalent diagram in Figure 1.5 comprises all quantities necessary for error calculations. The primary internal voltage drop does not affect the exciting current, and the errors — and therefore the primary internal impedance — are not indicated in the diagram. The secondary internal impedance, however, must be taken into account, but only the winding resistance  $R_i$ . The leakage reactance is negligible where continuous ring cores and uniformly distributed secondary windings are concerned. The exiting impedance is represented by an inductive reactance in parallel with a resistance.  $I_\mu$  and  $I_f$  are the reactive and loss components of the exciting current.

# 1. General principles of measuring current and voltage

The error calculation is performed in the following four steps:

1. The secondary induced voltage  $E_{si}$  can be calculated from

$$E_{si} = I_2 \times Z \text{ [V]}$$

where

$Z$  The total secondary impedance

$$Z = \sqrt{(R_i + R_b)^2 + X_b^2}$$

2. The inductive flux density necessary for inducing the voltage  $E_{si}$  can be calculated from

$$B = \frac{E_{si}}{\pi \times \sqrt{2} \times f \times A_j \times N_2}$$

where

$f$  Frequency in Hz

$A_j$  Core area in mm<sup>2</sup>

$N_2$  Number of secondary turns

$B$  Magnetic flux Tesla ( $T$ )

3. The exciting current,  $I_\mu$  and  $I_f$ , necessary for producing the magnetic flux  $B$ . The magnetic data for the core material in question must be known. This information is obtained from an exciting curve showing the flux density in Gauss versus the magnetizing force  $H$  in ampere-turns/cm core length.

Both the reactive component  $H_\mu$  and the loss component  $H_f$  must be given.

When  $H_\mu$  and  $H_f$  are obtained from the curve,  $I_\mu$  and  $I_f$  can be calculated from:

$$I_\mu = H_\mu \times \frac{L_j}{N_2} \text{ [A]}$$

$$I_f = H_f \times \frac{L_j}{N_2} \text{ [A]}$$

where

$L_j$  Magnetic path length in cm

$N_2$  Number of secondary turns

4. The vector diagram in Figure 1.4 is used for determining the errors. The vectors  $I_m$  and  $I_f$ , expressed as a percent of the secondary current  $I_2$ , are constructed in the diagram shown in Figure 1.6. The directions of the two vectors are given by the phase angle between the induced voltage vector  $E_{si}$  and the reference vector  $I_2$ .

$$\varphi = \frac{X_b}{R_i + R_b}$$

The reactive component  $I_\mu$  is 90 degrees out of phase with  $E_{si}$  and the loss component  $I_f$  is in phase with  $E_{si}$ .

### 1.2.3 Variation of errors with current

If the errors are calculated at two different currents and with the same burden it will appear that the errors are different for the two currents. The reason for this is the non-linear characteristic of the exciting curve. If a linear characteristic had been supposed, the errors would have remained constant. This is illustrated in Figure 1.7 and Figure 1.8. The dashed lines apply to the linear case.

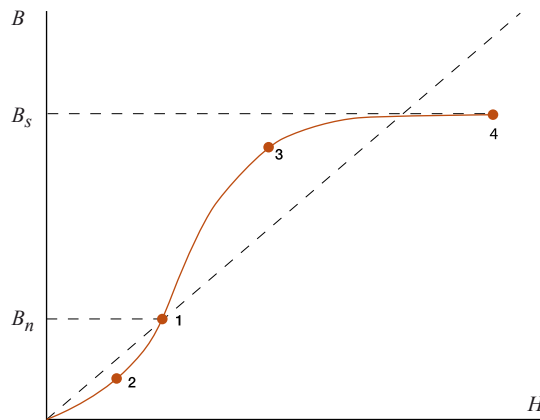

Figure 1.7

Figure 1.8 on next page, shows that the error decreases when the current increases. This goes on until the current and the flux have reached a value (point 3) where the core starts to saturate. A further increase of current will result in a rapid increase of the error. At a certain current  $I_{ps}$  (4) the error reaches a limit stated in the current transformer standards.

# 1. General principles of measuring current and voltage

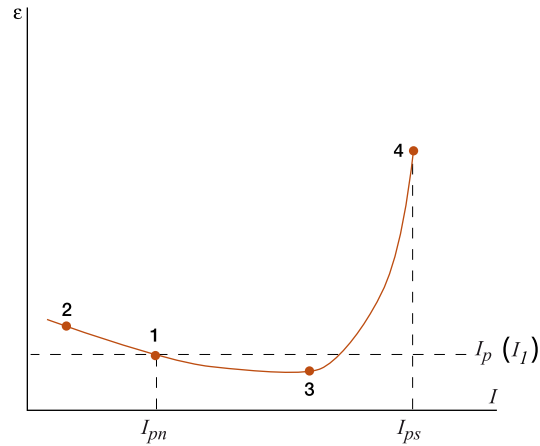

Figure 1.8

## 1.2.4 Saturation factor

$I_{ps}$  is called the instrument security current for a measuring transformer and accuracy limit current for a protective transformer. The ratio of  $I_{ps}$  to the rated primary current  $I_{pn}(I_I)$  is called the Instrument Security Factor ( $FS$ ) and Accuracy Limit Factor ( $ALF$ ) for the measuring transformer and the protective transformer respectively. These two saturation factors are practically the same, even if they are determined with different error limits.

If the primary current increases from  $I_{pn}$  to  $I_{ps}$ , the induced voltage and the flux increase at approximately the same proportion.

$$(FS)ALF = \frac{I_{ps}}{I_{pn}} \approx \frac{B_s}{B_n}$$

Because of the flat shape of the excitation curve in the saturated region,  $B_s$  could be looked upon as approximately constant and independent of the burden magnitude.  $B_n$ , however, is directly proportional to the burden impedance, which means that the formula above could be written

$$(FS)ALF \sim \frac{1}{B_n} \sim \frac{1}{Z}$$

The formula states that the saturation factor depends on the magnitude of the burden. This factor must therefore always be related to a certain burden. If the rated saturation factor (the saturation factor at rated burden) is given, the saturation factor for other burdens can be roughly estimated from:

$$ALF \approx ALF_n \times \frac{Z_n}{Z}$$

where

$ALF_n$	rated saturation factor
$Z_n$	rated burden including secondary winding resistance
$Z$	actual burden including secondary winding resistance

NOTE! For more accurate calculation, see chapter 2.6.3.

### 1.2.5 Core dimensions

Designing a core for certain requirements is always a matter of determining the core area. Factors, which must be taken into account in this respect, are:

- Rated primary current (number of ampere-turns)
- Rated burden
- Secondary winding resistance
- Accuracy class
- Rated saturation factor
- Magnetic path length

The procedure when calculating a core with respect to accuracy is in principle as follows:

A core area is chosen. The errors are calculated within the relevant burden and current ranges. If the calculated errors are too big, the core area must be increased and a new calculation must be performed. This continues until the errors are within the limits. If the errors in the first calculation had been too small the core area would have had to be decreased.

The procedure when calculating a core with respect to a certain saturation factor,  $ALF$ , is much simpler:

The core area  $\text{cm}^2$  can be estimated from the following formula:

$$A_j \approx K \times \frac{ALF \times I_{sn} \times Z_n}{N_s (N_2)}$$

where

$K$	Constant which depends on the core material (for cold rolled oriented steel K~25)
$I_{sn} (I_2)$	Rated secondary current
$Z_n$	Rated burden including the secondary winding resistance.

NOTE! It is important for low ampere turns that the accuracy is controlled according to the class.

# 1. General principles of measuring current and voltage

## 1.3 Voltage transformers operating principles

The following short introduction to voltage transformers concerns magnetic (inductive) voltage transformers. The content is, however, in general also applicable to capacitor voltage transformers as far as accuracy and measuring errors are concerned.

### 1.3.1 Measuring errors

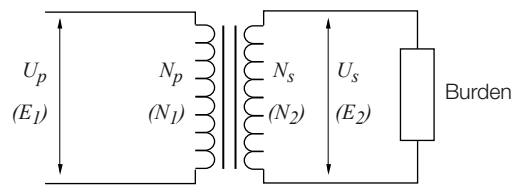

Figure 1.9

If the voltage drops could be neglected, the transformer should reproduce the primary voltage without errors and the following equation should apply to the primary and secondary voltages:

$$U_s = \frac{N_s}{N_p} \times U_p$$

In reality, however, it is not possible to neglect the voltage drops in the winding resistances and the leakage reactances. The primary voltage is therefore not reproduced exactly. The equation between the voltages will in this case be:

$$U_s = \frac{N_s}{N_p} \times U_p - \Delta U$$

where

$\Delta U$  Voltage drop

The error in the reproduction will appear both in amplitude and phase. The error in amplitude is called voltage error or ratio error, and the error in phase is called phase error or phase displacement.



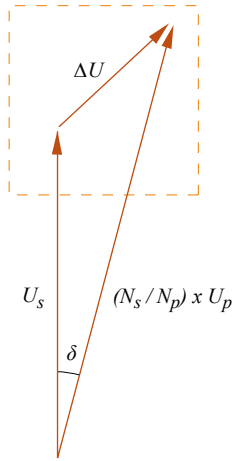

Figure 1.10

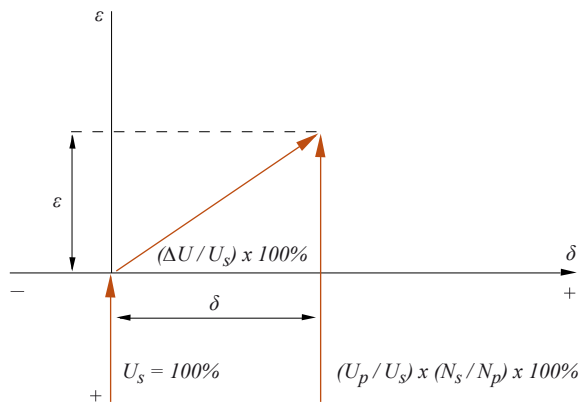

Figure 1.11

Figure 1.10 shows a vector representation of the three voltages. Figure 1.11 shows the area within the dashed lines on an enlarged scale. In Figure 1.11 the secondary voltage has been chosen as the reference vector and given the dimension of 100%. Moreover a system of coordinates with the axis divided into percent has been created with origin of coordinates on the top of the reference vector. Since  $\delta$  is a very small angle the voltage error  $\epsilon$  and the phase error  $\delta$  could be directly read in percent on the axis ( $\epsilon = 1\% = 1$  centiradian = 34.4 minutes).

According to the definition, the voltage error is positive if the secondary voltage is too high, and the phase error is positive if the secondary voltage is leading the primary. Consequently, the positive direction will be downwards on the  $\epsilon$  axis and to the right on the  $\delta$  axis.

# 1. General principles of measuring current and voltage

## 1.3.2 Determination of errors

Figure 1.12 shows an equivalent voltage transformer diagram converted to the secondary side.

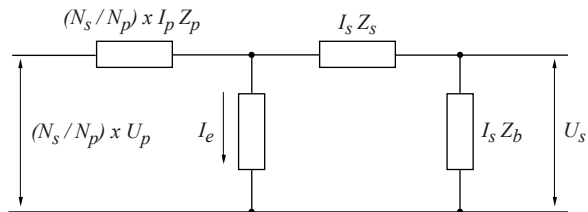

Figure 1.12

The impedance  $Z_p$  represents the resistance and leakage reactance of the primary,  $Z_s$  represents the corresponding quantities of the secondary. It is practical to look upon the total voltage drop as the sum of a no-load voltage drop caused by  $I_s$ . The diagram in Figure 1.12 is therefore divided into a no-load diagram shown by Figure 1.13 and a load diagram shown in Figure 1.14.

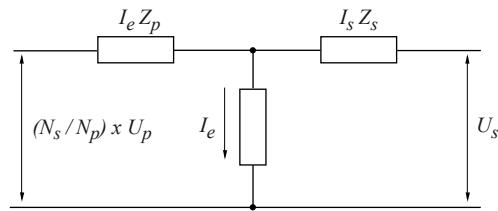

Figure 1.13

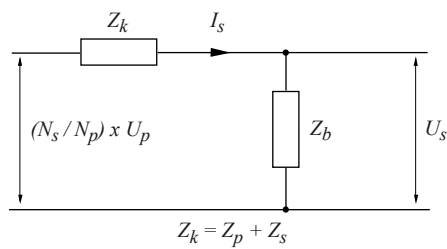

Figure 1.14

The no-load voltage drop is, in general, very small and moreover it is always of the same magnitude for a certain design. For these reasons, the no-load voltage drop will be given little attention in the future. The attention will be turned to Figure 1.14 and the load voltage drop  $\Delta U_b$

$$\Delta U_b = \frac{N_s}{N_p} \times U_p \times \frac{Z_k}{Z_k + Z_b}$$

$\Delta U_b$  can also be written

$$\Delta U_b = U_s \times \frac{Z_k}{Z_b}$$

The voltage drop expressed as a percent of  $U_s$  is:

$$\Delta U_b = \frac{Z_k}{Z_b} \times 100$$

$\Delta U_b$  consists of a resistive and a reactive component

$$\Delta U_r = \frac{R_k}{Z_b} \times 100$$

and

$$\Delta U_x = \frac{X_k}{Z_b} \times 100$$

The vector diagram in Figure 1.11 is used for determining the errors. The two vectors  $\Delta U_r$  and  $\Delta U_x$  are constructed in the diagram shown by Figure 1.15.

The direction of the two vectors is given by the phase angle between the load current vector  $I_s$  and the reference vector  $U_s$

$$\varphi = a \tan \frac{X_b}{R_b}$$

The resistive component  $\Delta U_r$  is in phase with  $I_s$  and the reactive component  $\Delta U_x$  is 90° out of phase with  $I_s$ .

# 1. General principles of measuring current and voltage

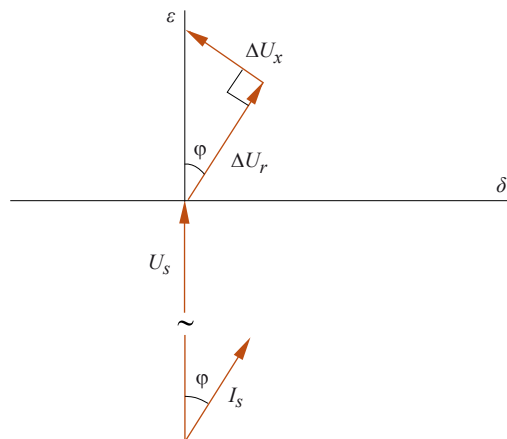

## 1.3.3 Calculation of the short-circuit impedance $Z_k$

Figure 1.16 shows, in principle, how the windings are built up. All quantities, which are of interest concerning  $Z_k$ , are given in the figure.

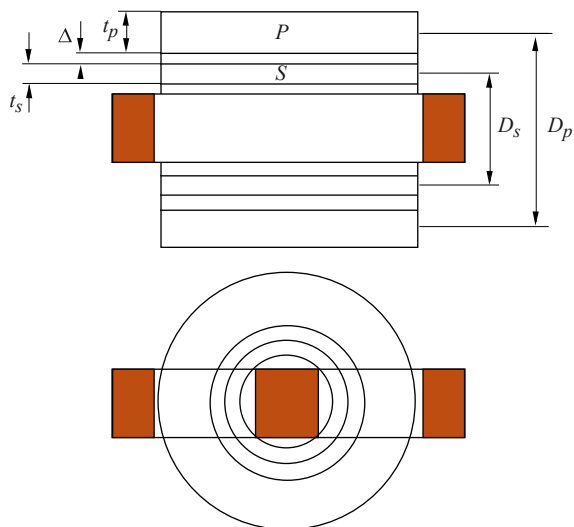

Figure 1.16

The two components  $R_k$  and  $X_k$  composing  $Z_k$  are calculated in the following way.

- $R_k$  is composed of the primary and secondary winding resistances  $R_p$  and  $R_s$ ;  $R_p$  converted to the secondary side.

$$R_k = \left( \frac{N_s}{N_p} \right)^2 \times R_p + R_s$$

$R_p$  is calculated from:

$$R_p = 0.018 \times \frac{\pi \times D_p \times N_p}{a_p} [\Omega]$$

where

$D_p$	Mean diameter of primary winding in meters
$a_p$	Area of primary conductor in mm <sup>2</sup>

$R_s$  is calculated in the same way.

- $X_k$  is caused by the leakage flux in the windings and it may be calculated from:

$$8 \times f \times N^2 \times \frac{\pi \times D_m}{L} \times \left( \Delta + \frac{t_p + t_s}{3} \right) \times 10^{-8} [\Omega]$$

where

$D_m$	Mean value of $D_p$ and $D_s$ (all dimensions in cm)
-------	--

### 1.3.4 Variation of errors with voltage

The errors vary if the voltage is changed. This variation depends on the non-linear characteristic of the exciting curve which means that the variation will appear in the no-load errors. The error contribution from the load current will not be affected at all by a voltage change.

The variation of errors is small even if the voltage varies with wide limits. Typical error curves are shown in Figure 1.17.

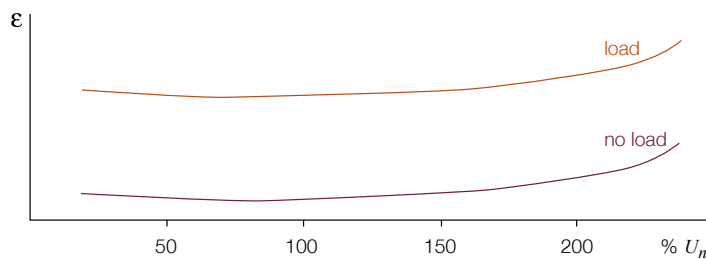

Figure 1.17

# 1. General principles of measuring current and voltage

## 1.3.5 Winding dimensions

Designing a transformer for certain requirements is always a matter of determining the cross-sectional area of the winding conductors. Factors, which must be taken into account in this respect, are:

- Rated primary and secondary voltages
- Number of secondary windings
- Rated burden on each winding
- Accuracy class on each winding
- Rated frequency
- Rated voltage factor

The procedure is in principle as follows:

1. The number of turns are determined from

$$N = \frac{U_n}{\pi \times \sqrt{2} \times f \times A_j \times B_n}$$

where

$N$  Number of turns (primary or secondary)

$U_n$  Rated voltage (primary or secondary)

$f$  Rated frequency in Hz

$A_j$  Core area in m<sup>2</sup>

$B_n$  Flux density at rated voltage (Tesla)

The value of  $B_n$  depends on the rated voltage factor.

2. Determination of the short-circuit resistance  $R_k$

The highest percentage resistive voltage drop  $\Delta U_r$ , permissible for the approximate accuracy class is estimated.  $R_k$  is determined from  $\Delta U_r$  and the rated burden impedance  $Z_b$

$$R_k = \frac{\Delta U_r}{100} \times Z_b$$

3. The cross-sectional areas of the primary and secondary winding conductors are chosen with respect to the calculated value of  $R_k$ .
4. The short-circuit reactance  $X_k$  is calculated when the dimensions of the windings are determined.
5. The errors are calculated. If the errors are too high the area of the winding conductors must be increased.

If a transformer is provided with two measuring windings it is often prescribed that each of these windings shall maintain the accuracy, when the other winding

is simultaneously loaded. The load current from the other winding passes through the primary winding and gives rise to a primary voltage drop, which is introduced into the first winding. This influence must be taken into account when designing the windings.

### 1.3.6 Accuracy and burden capability

For a certain transformer design, the burden capability depends on the value of the short-circuit impedance. A low value for the short-circuit impedance (a high quantity of copper) means a high burden capability and vice versa. The burden capability must always be referred to a certain accuracy class.

If 200 VA, class 1 is performed with a certain quantity of copper, the class 0.5 capability is 100 VA with the same quantity of copper, on condition that the turns correction is given values adequate to the two classes. The ratio between accuracy class and burden capability is approximately constant. This constant may be called the "accuracy quality factor"  $K$  of the winding

$$K = \frac{100 \times A}{P}$$

where

$A$	Accuracy class
$P$	Rated burden in VA

## 1.4 Capacitor Voltage Transformer (CVT)

The capacitor voltage transformer is the most used voltage transformer for high voltages > 100 kV.

The application for capacitor voltage transformers - CVTs - is the same as for inductive voltage transformers. In addition to those, the CVT can also be used as a coupling capacitor in combination with power line carrier - PLC - equipment for telecommunication, remote control etc.

The dual function - voltage transformer and coupling capacitor - makes the CVT to an economic alternative also for voltages <100 kV.

The CVT consists of two parts, the capacitive voltage divider – CVD – with the two capacitances  $C_1$  and  $C_2$  and the electromagnetic unit – EMU.

The size of the capacitances  $C_1$  and  $C_2$  determines the voltage ratio of the CVD.

The EMU contains an inductive voltage transformer, a tuning reactance and a protection against ferro-resonance.

The basic theory regarding accuracy classes, ratio and phase errors etc is the same for CVTs as for inductive voltage transformers.

# 1. General principles of measuring current and voltage

## 1.4.1 Characteristics of a CVT

The capacitor voltage divider — CVD, contains two series connected capacitors,  $C_1$  and  $C_2$ . The voltage divider is loaded by an electromagnetic unit — EMU, which contains sufficient inductance for compensation of the capacitance in the CVD. The compensation inductance is obtained from the transformer windings and from a specially design tuning reactor.

The complete circuit diagram is shown in Figure 1.18, where the EMU is represented by the primary resistance  $R_1$  and inductance  $L_1$ . Corresponding on the secondary side is  $R_2$  and  $L_2$ .  $R_t$  and  $L_t$  are resistance and inductance of the tuning reactor. The magnetizing impedance is represented by the resistance  $R_m$  in parallel with inductance  $L_m$ . The losses of the capacitor section are represented by  $R_{c1}$  and  $R_{c2}$ .

The total series-inductance includes the leakage inductance  $L_1 + L_2$  and the tuning inductance  $L_t$ .

The impedance  $Z_b$  represents the load connected to the secondary terminals. Figure 1.18 can be converted to an equivalent circuit according to Figure 1.19.

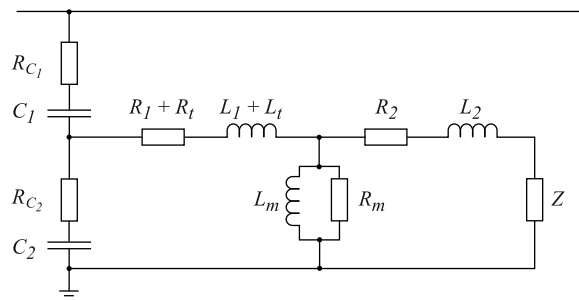

Figure 1.18

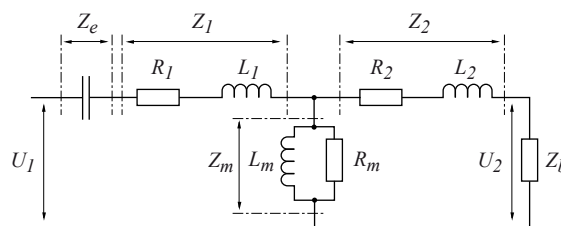

Figure 1.19

If the load  $Z_b$  is excluded the CVT at no-load can be expressed as:

$$U_2 = \frac{Z_m}{Z_m + Z_1 + Z_2} \times U_1$$



And the ratio and phase errors at no load can be derived:

$$\varepsilon_{\theta} + j\delta = \frac{U_2 - U_1}{U_1} = -\frac{Z_1 + Z_e}{Z_m + Z_1 + Z_2}$$

When the CVT is loaded with the impedance  $Z_b$ , which consumes the current  $I$  the following relation between primary and secondary voltages is obtained:

$$U_2 = \frac{Z_m}{Z_m + Z_1 + Z_e} \times \frac{C_1}{C_1 + C_2} \times U - \left[ Z_2 + \frac{Z_m(Z_1 + Z_e)}{Z_m + Z_1 + Z_e} \right] \times I$$

Since the magnetizing impedance  $Z_m$  is of the order 500 - 1000 times the impedance ( $Z_e + Z_1$ ) it can be disregarded and the simplified equivalent circuit according to Figure 1.20 can be used for calculations.

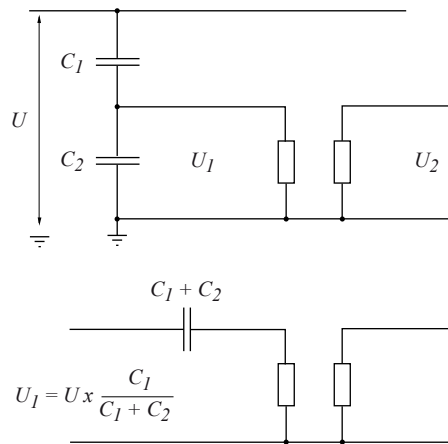

Figure 1.20

The two capacitors  $C_1$  and  $C_2$  are build from identical capacitor elements and their phase displacement can be regarded the same. The loss angle for modern capacitors is very low, <0.2%, why the losses can be neglected. Seen from the EMU we get:

$$Z_e = \frac{\frac{1}{j\omega C_1} \times \frac{1}{j\omega C_2}}{\frac{1}{j\omega C_1} + \frac{1}{j\omega C_2}} = \frac{1}{j\omega(C_1 + C_2)}$$

$C_1 + C_2 = C_e$  is called the equivalent capacitance and is used for many calculations.

# 1. General principles of measuring current and voltage

The intermediate voltage, i.e. the voltage for the EMU is:

$$U_1 = \frac{\frac{1}{j\omega C_2}}{\frac{1}{j\omega C_1} + \frac{1}{j\omega C_2}} \times U = \frac{C_1}{(C_1 + C_2)} \times U$$

$$n_c = \frac{C_1 + C_2}{C_1} \text{ is the voltage ratio of the capacitor}$$

The ratio of the EMU is defined according to the same rules as for inductive voltage transformers:

$$n_t = \frac{N_1}{N_2} = \frac{U_1}{U_2}$$

Total ratio, from high voltage side of CVD to secondary side of EMU:

$$n_{tot} = n_c \cdot n_t = \frac{U_1}{U_2} = \frac{C_1 + C_2}{C_1}$$

This is same as for inductive voltage transformers, only difference is the capacitance  $C_e$  in series with the primary winding.

## 1.4.2 The CVT at no-load

Using the equivalent circuit, the properties of a CVT is easiest studied in a vector diagram. See Figure 1.21. The square represents the limits for an accuracy class.

The location of the point  $N-L$ , the no-load voltage drop is determined by the losses of the transformer and the total resistance in the primary winding and reactor.

Figure 1.21 shows a CVT without turn correction, where the no-load point is located at a small negative ratio error and a small positive phase displacement. To keep the phase displacement at no-load at a minimum, the major part of the inductive compensation reactance of the EMU must be in the primary circuit so the excitation current flows through a tuned circuit.

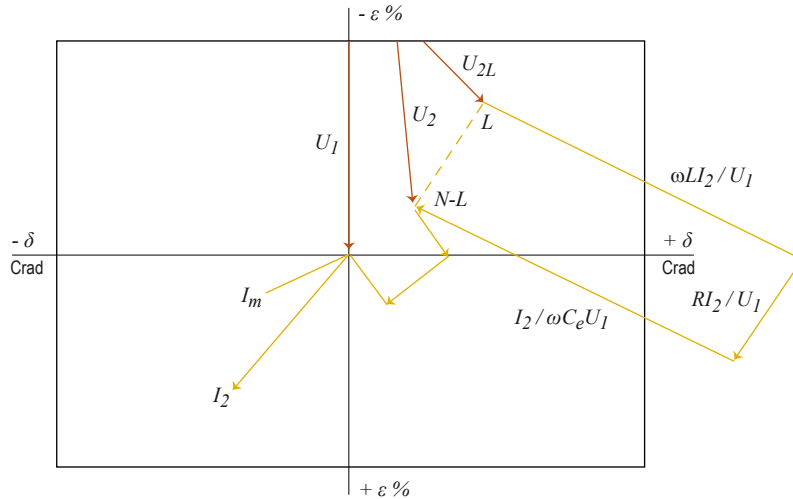

Figure 1.21

### 1.4.3 The CVT at load

When the transformer is loaded with an impedance, an additional voltage drop occurs in the circuit due to the load current. The location of the load point  $L$  is determined by the same parameters as the no-load point plus the impedance in the secondary circuit.

The ratio  $n_t$  of the transformer influences the voltage drop in the primary circuits, since the load current in the primary winding is determined by the ratio. A high intermediate voltage is an advantage since it will reduce the current and give better properties to the EMU.

Like for an inductive voltage transformer, the CVT will always have a negative ratio error. Turns correction is therefore always made in order to use also the positive half of the accuracy class. Since the accuracy shall be maintained from 25% of rated burden it is possible, by turns correction, to place the no-load point outside the accuracy class.

Turns correction is just a parallel movement of the vector diagram in the direction of ratio error. See Figure 1.22.

An increased positive ratio error is obtained by a reduction of the primary turns. Turns correction is easily made due to the large number of turns.

# 1. General principles of measuring current and voltage

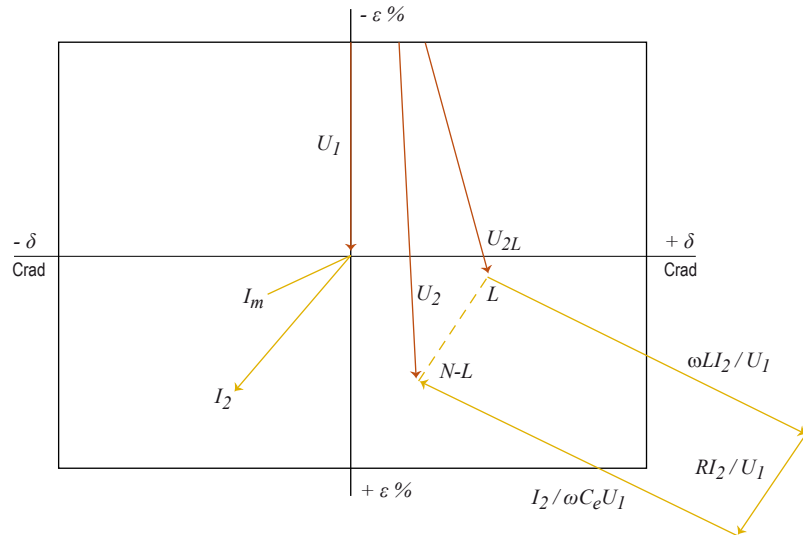

Figure 1.22

Capacitive and inductive reactances are tuned and the following is valid at rated frequency:

$$\omega L = \frac{1}{\omega C}$$

Exact tuning means that the reactive voltage drop is eliminated in CVTs. It is therefore possible to simplify the circuit for calculations to show only the internal resistance of the EMU.

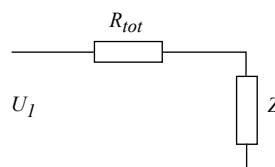

Figure 1.23

## 1.4.4 Calculation of internal resistance and load point for other burden than rated

Assume the following ratings for the CVT:

Accuracy class	0.5
Rated burden	200 VA
Rated voltage	$110/\sqrt{3}$ V

Maximum permitted voltage drop  $\Delta U$  can be approximated to  $2 \times 0.5 = 1\%$ . The burden range is 25 - 100% of the rated burden, i.e. between 50 and 200 VA = 150 VA.

$$R = \frac{\Delta U}{I} = \frac{1}{100} \times \frac{110}{\sqrt{3}} \times \frac{110}{\sqrt{3} \times 150} = 0.27 \Omega$$

A more accurate calculation can be made if the test reports for the transformer are available. In such case the ratio errors at no-load and at load are measured and they represent the voltage drop in percent.

The ratio error for a voltage transformer is a linear function of the connected load. The ratio error for any burden can therefore be determined if the errors at no-load and at a known burden has been determined.

The errors at no-load, 0 VA, and at load 200 VA are marked in an error diagram, see Figure 1.24, and the errors at, for instance, 300 VA can be determined by extrapolation of the voltage drop between 0-200 VA.

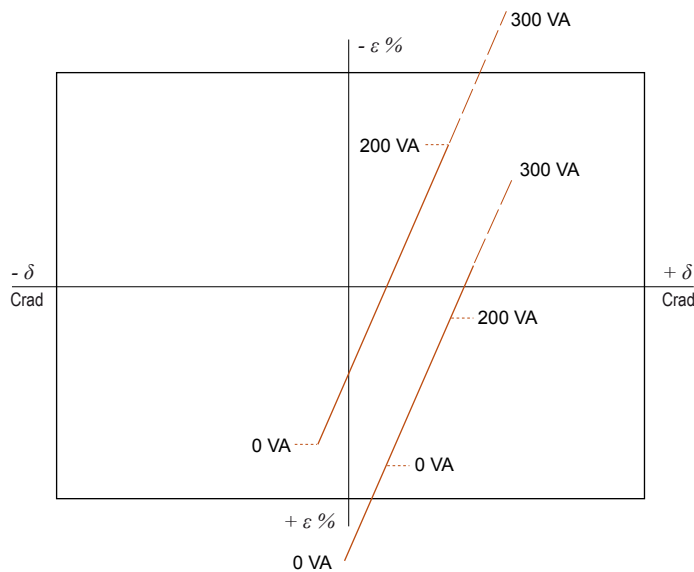

Figure 1.24

Some designs of CVTs have the possibility of an external turn correction, ratio adjustment, and they can be field adjusted to be within the accuracy class for burdens higher than rated burden or be adjusted to have a minimum (almost 0%) ratio error for the connected burden.

The ratio adjustment is made by connection of a number of separate windings, in different combinations, in series or reverse to the primary winding.

# 1. General principles of measuring current and voltage

## 1.4.5 Inclination of the load line

The tuning reactance in the EMU makes it possible to change the inclination, in the error diagram, of the load line to an optimum position. By an overcompensation,

$$\omega L > \frac{1}{\omega C_e}$$

it is possible to give the CVT an inductive characteristic on the secondary side, in the same way as for an inductive voltage transformer.

## 1.4.6 Frequency dependence of a CVT

The fundamental function of the CVT is resonance between the capacitive and inductive reactance at rated frequency. It can therefore not be expected that the CVT will have the same accuracy for frequencies deviating from the rated.

The standards, IEC 60044-5, specifies that for a metering class the accuracy shall be maintained for a frequency variation between 99-101% of rated frequency and for protection class between 96-102%.

The sensitivity for frequency variations is dependent on the equivalent capacitance and the intermediate voltage. High values give a lower sensitivity and smaller variations.

A purely resistive burden will give error variation only for phase displacement and an inductive burden gives variation both in ratio and in phase.

Figure 6 shows an example of frequency variation for the range 49 - 51 Hz with burdens having  $\cos\phi = 1$  and 0.8 inductive.

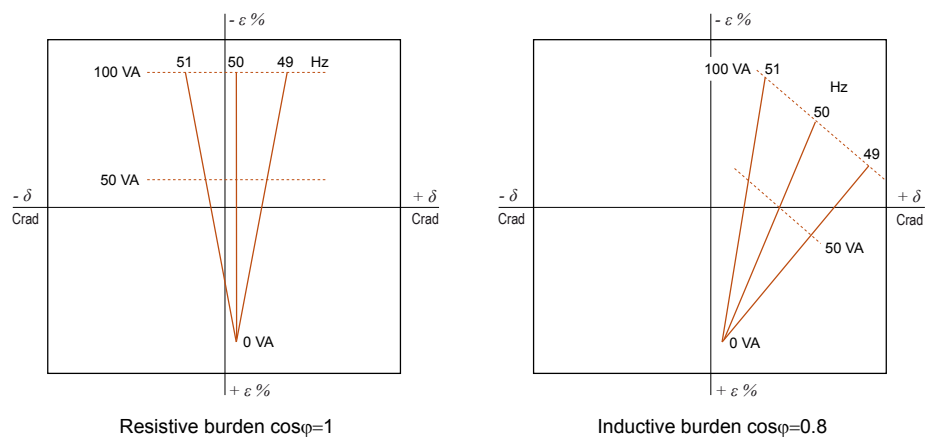

Figure 1.25

#### 1.4.7 Error changes for voltage variations

Like for an inductive voltage transformer, the errors of a CVT change very little for voltage variations. The voltage dependence can for all practical applications be neglected.

The accuracy requirements (IEC) are the same for CVTs as for inductive voltage transformers:

Metering classes according to IEC 186:	80 - 120% rated voltage 25 - 100% rated burden
Protection classes according to IEC 186:	5% - $V_f$ times rated voltage 25 - 100% rated burden.

#### 1.4.8 Different power factor of the burden

The inclination of the load line, in an error diagram, is changes by the power factor of the burden. Like for an inductive voltage transformer, the load line rotates in the error diagram, clock-wise for inductive burdens. By the tuning reactance of the EMU it is possible to adjust the phase displacement to a minimum for rated burden. It must though be considered other factors influencing the errors so that the accuracy class is complied to.

#### 1.4.9 Error variation for temperature changes

The temperature characteristic of a CVT is rather complex and only a few factors influencing the errors of a CVT will be dealt with here.

The capacitance of the CVD changes by temperature. The size of the change depends on the type of dielectric used in the capacitor elements. The relation between capacitance and temperature can be written:

$$C = C_0(1 + \alpha \times \Delta T)$$

where

$\alpha$	Temperature coefficient for the capacitor dielectric
$\Delta T$	Temperature change

# 1. General principles of measuring current and voltage

The variation of capacitance means two different kinds of temperature dependence.

- If the two capacitors  $C_1$  and  $C_2$  in the voltage divider can get different temperature or if they, due to design, have different values of  $\alpha$ , the voltage ratio of the CVD, changes by temperature. This will have an influence on the ratio error –  $\epsilon$ . It is therefore essential that the design is such that all capacitor elements have the same dielectric and have the same operating conditions. CVD's having  $C_1$  and  $C_2$  enclosed in the same porcelain have shown very good temperature stability.

$$n_c = \frac{C_1 + C_2}{C_1}$$

- Another temperature dependence is caused by the changes of the capacitive reactance:

$$\frac{1}{\omega C_e}$$

This temperature dependence influences the tuning of the CVT and gives additional errors of the same kind as for frequency variations and is proportional to the connected burden.

Low temperature coefficient is essential to keep these variations small.

A third remaining factor influencing the errors, is the change of winding resistance in the EMU due to temperature variations. This is also valid for inductive voltage transformers and the effect is limited by using large cross-section area of winding conductors.

Designs of capacitors having only paper and mineral oil as dielectric have a big variation of capacitance by temperature. Typical values of  $\alpha$  could be in the range 0.2-0.4% / °C. Using this kind of dielectric makes it impossible to design a CVT for class 0.2 accuracy, provided consideration is taken to all the other factors influencing the errors.

Capacitors using a mixed dielectric with paper/plastic films and a synthetic fluid as insulation have temperature coefficients in the range 0.01-0.04% / °C. The influence on errors from capacitance variations can more or less be neglected and by taking this into consideration when making the design, it is possible to manufacture CVTs with the same temperature stability as an inductive voltage transformer.



### 1.4.10 Quality factor

The performance, like frequency dependence of accuracy, possibility to meet high accuracy at high burdens and the amplitude of the transient response of a CVT can be related to a "quality factor":

$$Q = C_e \times U_m^2$$

$$C_e = \text{equivalent capacitance} = C_1 + C_2$$

$$U_m = \text{intermediate voltage} = \frac{U_n}{\sqrt{3} \times \text{capacitor ratio}}$$

Change of phase displacement due to frequency variations can be written:

$$\Delta\delta = \frac{B(X + Y\%)}{2\pi f Q}$$

where

$\Delta\delta$	Variation of phase displacement	
$B$	Connected burden in VA	
$X$	Frequency range in % for the accuracy class in applicable standard	$\pm \left( \frac{\omega}{\omega_n} - \frac{\omega_n}{\omega} \right) \times 100\%$
$Y$	Step size in % of the tuning reactance	
$f$	Rated frequency in Hz	

It is seen that a high value of the quality factor  $Q$  is essential for keeping the error variations small.

Example: Compare the performance for the IEC standard frequency range  $\pm 1\%$  for two different CVTs.

CVT type		A	B
Equivalent capacitance	$C_e$ ( $\mu\text{F}$ )	0.082	0.074
Intermediate voltage	$U_m$ (kV)	14	6
Burden	$B$ (VA)	100	100
Adjustment step	$Y$ (%)	1.2	1.2
Frequency range	$X$ (%)	2	2
Quality factor	$Q$	16.1	2.7
$\Delta\delta$	centiradians	0.06	0.38

# 1. General principles of measuring current and voltage

The CVT of type B will not fulfil class 0.2 requirement for a burden of 100 VA, when considering that the total permitted phase displacement is  $\pm 0.3$  centiradians.

Figure 1.26 on next page show how the amplitude of the transient response is influenced by the equivalent capacitance and intermediate voltage, i.e. the quality factor.

## 1.4.11 Leakage currents and stray capacitance

The capacitor voltage divider is normally built up from a number of series connected porcelain sections. Pollution on the external surface of the porcelains will be equivalent to a parallel resistance to the capacitor elements and an uneven distribution of pollution between sections can therefore be expected to have an influence on the accuracy.

It can though be shown that the higher capacitance in the divider, the smaller influence on accuracy.

Measurements on CVTs in dry, wet and polluted conditions have shown that the influence on ratio and phase errors is very small and can be neglected for CVTs having a high capacitance.

In a substation where there is stray capacitance to other objects an influence on accuracy can be suspected. A high capacitance is advantageous in this respect and practical experience show that this is not a problem in outdoor substations.

## 1.4.12 Transient behavior

The design with capacitive and inductive elements means that the CVT has more complex transient behavior than an inductive voltage transformer.

## 1.4.13 Transient response

The transient response is the ability of a CVT to reproduce rapid changes of the primary voltage and is defined as the remaining secondary voltage at a specified time after a short circuit of the primary voltage.

The remaining voltage is dependent on design parameters of the CVT, but also on the size and power factor of the connected burden.

Figure 1.26 shows some examples of influence on transient response. It can be shown that a high equivalent capacitance and a high intermediate voltage reduce the transient. High burden gives higher amplitude of the transient than a low burden, inductive power factors also makes the transient bigger.

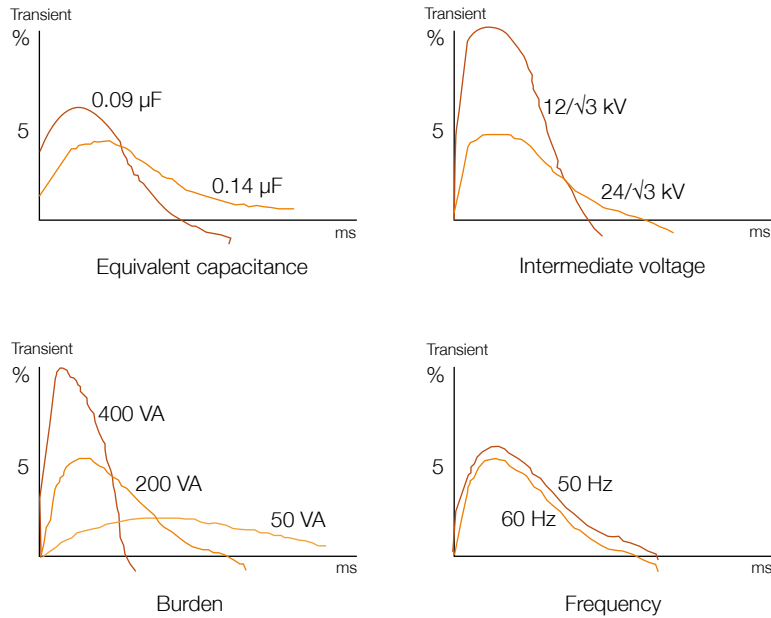

Figure 1.26

#### 1.4.14 Ferro-resonance

In a circuit containing non-linear inductance and capacitance, it may be initiated oscillations. When designing the CVT it is therefore essential that such oscillations are avoided. All CVTs are provided with some type of ferro-resonance damping device, to protect the CVT from being damaged by over-voltages or overheated due to core saturation. To have a safe and reliable damping device is essential for the survival of the CVT in case ferro-resonance occurs.

The damping device can be designed in several ways. Designs with only load resistors give additional errors and designs with electronic or tuned circuits have the disadvantage that they must be tuned for certain frequencies of the oscillations and will not at all damp other frequencies.

## 2. How to specify current transformers

Important main factors when selecting current transformers are:

- Standard (IEC, IEEE or national)
- Rated insulation level (service voltage)
- Altitude above sea level (if >1000 m)
- Ambient temperature (daily temperature or average over 24 hours)
- Rated primary current
- Rating factor (maximum continuous current)
- Rated secondary current
- Short-time current
- Dynamic current
- Number of cores
- Burdens (outputs) and accuracies for each core
- Pollution level (creepage distance)

### 2.1 Rated insulation level

The current transformer must withstand the operational voltage and overvoltages in the network. Test voltages are specified in the standards in relation to the system voltage. These tests shall show the ability of a current transformer to withstand the overvoltages that can occur in the network. The lightning impulse test is performed with a wave shape of 1.2/50  $\mu$ s and simulates a lightning overvoltage. For current transformers with a system voltage of 300 kV and more the switching impulse test is performed with a wave shape of 250/2500  $\mu$ s simulating switching overvoltages. It is performed as a wet test. For voltages below 300 kV a wet power frequency test is performed instead.

The dielectric strength of air decreases as altitude increases. Consequently, for installation at an altitude higher than 1000 m above sea level, the external insulation (arcing distance) of the transformer has to be adapted to the actual site altitude.

Note that as far as the internal insulation is concerned, the dielectric strength is not affected by altitude.

According to IEC 61869-1 the arcing distance under the standardized atmospheric conditions is determined by multiplying the withstand voltages required at the service location by a factor  $k$ .

$$k = e^{m \times (H - 1000) / 8150}$$

where

$H$	Altitude above sea level in meters
$m$	1 for power frequency and lightning impulse voltage
$m$	0.75 for switching impulse voltage

According to IEEE dielectric strength that depends on air should be multiplied by an altitude correction factor to obtain the dielectric strength at the required altitude, according to the following table:

Altitude above sea level (m)	Altitude correction factor for dielectric strength
1000	1.00
1200	0.98
1500	0.95
1800	0.92
2100	0.89
2400	0.86
2700	0.83
3000	0.80
3600	0.75
4200	0.70
4500	0.67

#### Rated insulation levels according to IEC 61869-1

Max. System voltage	Power frequency withstand voltage		Lightning impulse withstand voltage	Switching impulse withstand voltage	RIV test voltage	Max. RIV level	PD test voltage	Max. PD level
	Dry	Wet						
kV	kV	kV	kV	kV	kV	μV	kV	pC
36	70	70	170	-	-	-	43	10
52	95	95	250	-	-	-	63	10
72.5	140	140	325	-	-	-	86	10
123	230	230	550	-	78	250	148	10
145	275	275	650	-	92	250	174	10
170	325	325	750	-	108	250	204	10
245	460	460	1050	-	156	250	276	10
300	460	-	1050	850	191	250	360	10
362	510	-	1175	950	230	2500	434	10
420	630	-	1425	1050	267	2500	420*	10
550	680	-	1550	1175	334	2500	550*	10
800	975	-	2100	1550	485	2500	800*	10

Test voltages above apply at ≤ 1000 m above sea level. \* Earthed neutral system

## 2. How to specify current transformers

**Basic insulation levels according to IEEE C57.13 -2008**

Max. System voltage	Power frequency withstand voltage		Lightning impulse withstand voltage	Chopped wave test voltage	RIV test voltage	Max. RIV level
	Dry	Wet				
kV	kV	kV	kV	kV	kV	$\mu$ V
36.5	70	70	200	230	-	-
48.3	95	95	250	290	-	-
72.5	140	140	350	400	-	-
123	230	230	550	630	78	250
145	275	275	650	750	92	250
170	325	315	750	865	108	250
245	460	445	1050	1210	156	250
362	575	-	1300	1500	230	2500
550	800	-	1800	2070	334	2500
800	920	-	2050	2360	485	2500

Test voltages above apply at  $\leq 1000$  m above sea level.

### 2.2 Rated primary current

The current transformer must also withstand the rated primary current in continuous operation. Here, the average ambient temperature must be taken into account, if there is a deviation from the standard. Current transformers are normally designed according to IEC 60044-1 and IEEE C57.13 standards, i.e. for 35 °C (30 °C) average ambient air temperature.

The primary rated current should be selected to be approximately 10% - 40% higher than the estimated operating current, which gives a high resolution on the metering equipment and instruments. The closest standard value, decimal multiples of 10, 12.5, 15, 20, 25, 30, 40, 50, 60 or 75 A, should be chosen.

In order to obtain several current ratios, current transformers can be designed with either primary or secondary reconnection or a combination of both.

#### Primary reconnection

A usual way to change ratio is to have two separated primary windings, which can be connected, either in series or in parallel. The advantage is that the number of ampere-turns will be identical at all different ratios. Thus output and class will also be identical at all current ratios. The most usual design is with two different ratios, in relation 2:1, but three current ratios in relation 4:2:1 are also available.

However, as the short-time withstand current will be reduced when the primary windings are connected in series compared to the parallel connected winding, the short-circuit capability is reduced for the lower ratios.

### Secondary reconnection

For high rated currents and high short-time currents (> 40 kA) normally only one primary turn is used. Reconnection is made with extra secondary terminals (taps) taken out from the secondary winding. In this case the number of ampere-turns and also the output will be reduced at the taps, but the short-circuit capacity remains constant. The accuracy rating applies to the full secondary winding, unless otherwise specified.

### IEC 60044-1, IEEE C57.13

Combinations of reconnections both at the primary and the secondary side are also possible, providing several different ratios with few secondary taps.

### Multi-ratio IEEE C57.13 -2008

Current ratings (A)	Secondary taps	Current ratings (A)	Secondary taps
<b>600:5</b>		<b>3000:5</b>	
50:5	X2 - X3	300:5	X3 - X4
100:5	X1 - X2	500:5	X4 - X5
150:5	X1 - X3	800:5	X3 - X5
200:5	X4 - X5	1000:5	X1 - X2
250:5	X3 - X4	1200:5	X2 - X3
300:5	X2 - X4	1500:5	X2 - X4
400:5	X1 - X4	2000:5	X2 - X5
450:5	X3 - X5	2200:5	X1 - X3
500:5	X2 - X5	2500:5	X1 - X4
600:5	X1 - X5	3000:5	X1 - X5
<b>1200:5</b>		<b>4000:5</b>	
100:5	X2 - X3	500:5	X1 - X2
200:5	X1 - X2	1000:5	X3 - X4
300:5	X1 - X3	1500:5	X2 - X3
400:5	X4 - X5	2000:5	X1 - X3
500:5	X3 - X4	2500:5	X2 - X4
600:5	X2 - X4	3000:5	X1 - X4
800:5	X1 - X4	3500:5	X2 - X5
900:5	X3 - X5	4000:5	X1 - X5
1000:5	X2 - X5		
1200:5	X1 - X5		
<b>2000:5</b>		<b>5000:5</b>	
300:5	X3 - X4	500:5	X2 - X3
400:5	X1 - X2	1000:5	X4 - X5
500:5	X4 - X5	1500:5	X1 - X2
800:5	X2 - X3	2000:5	X3 - X4
1100:5	X2 - X4	2500:5	X2 - X4
1200:5	X1 - X3	3000:5	X3 - X5
1500:5	X1 - X4	3500:5	X2 - X5
1600:5	X2 - X5	4000:5	X1 - X4
2000:5	X1 - X5	5000:5	X1 - X5

## 2. How to specify current transformers

### 2.3 Rated continuous thermal current

The continuous rated thermal current is the current which can be permitted to flow continuously in the primary winding without the temperature rise exceeding the values stipulated in the standards. Unless otherwise specified it is equal to the rated primary current, i.e. the rating factor is 1.0.

In applications where the actual currents are higher than the rated current, a rating factor must be specified. With a rating factor of for instance 1.2 the current transformer must withstand a continuous current of 1.2 times the rated current. The accuracy for metering cores must also be fulfilled at this current. In IEC 60044-1 it is called extended current rating and has standard values of 120%, 150% and 200% of the rated primary current.

### 2.4 Rated secondary current

The secondary rated current can be 1 or 5 A, but there is a clear trend towards 1 A. 2 A rated current is also frequently used in Sweden.

As modern protection and metering equipment have relatively low burdens, the burdens in the cables are predominant ones. The cable burden is  $I^2R$ , i.e. a 1 A circuit has a cable burden 25 times lower in VA compared to a 5 A circuit. The lower burden needed for 1 A reduces the size and the cost of current transformer cores.

### 2.5 Short-time thermal current ( $I_{th}$ ) and dynamic current ( $I_{dyn}$ )

This is the maximum current, which the transformer can withstand for a period of one second, without reaching a temperature that would be disastrous to the insulation, e.g. 250 °C for oil immersed transformers.

If the short-time thermal current is not specified, it can be calculated by using the formula:

$$I_{th} = \frac{S_k}{U_n \times \sqrt{3}} [kA]$$

where

$S_k$	The fault level in MVA at the point where the current transformer is to be installed.
$U_n$	Rated service voltage (line-to-line) in kV



A current transformer is connected in series with the network and it is therefore essential to ensure that the current transformer can withstand the fault current, which may arise at its position. If the current transformer should break down, the entire associated equipment would be left unprotected, since no information will then be submitted to the protective relays. The protective equipment will be both “blind” and “deaf”.

The short-time current for periods other than one second  $I_x$  can be calculated by using the following formula:

$$I_x = \frac{I_t}{\sqrt{x}}$$

where

---

$X$  The actual time in seconds

---

The short-time thermal current has a thermal effect upon the primary winding. In the event of a short-circuit, the first current peak can reach approximately 2.5 times  $I_{th}$ . This current peak gives rise to electromagnetic forces between the turns of the primary winding and externally between the phases in the primary connections. A check should therefore be made to ensure that the current transformer is capable of withstanding the dynamic current as well as the short-time thermal current.

NOTE! It is very important to adapt requirements imposed on short-time current to a real level. Otherwise, especially at low rated currents, the low number of ampere-turns must be compensated for by increasing the core volume. This will result in large and expensive current transformer cores.

To increase the number of ampere-turns at lower currents with a given core size, the number of primary turns in the current transformer can be increased. As a consequence the primary short-circuit current ( $I_{th}$ ) will be lower for a higher number of primary turns. At high short-time currents and low rated currents the number of ampere-turns will be very low and the output from the secondary side will thus be limited.

## 2. How to specify current transformers

### Rated short-time thermal current ( $I_{th}$ )

Standard r.m.s values, expressed in kilo amperes, are:

6.3	8	10	12.5	16	20	25	31.5	40	50	63	80	100
-----	---	----	------	----	----	----	------	----	----	----	----	-----

### Dynamic peak current ( $I_{dyn}$ )

IEC 50 Hz	$2.5 \times I_{th}$
IEC 60 Hz	$2.6 \times I_{th}$
ANSI/IEEE 60 Hz	$2.7 \times I_{th}$

### 2.6 Burden and accuracy

In practice all current transformer cores should be specially adapted for their application for each station. Do not specify higher requirements than necessary.

#### 2.6.1 Measurement of current

The output required from a current transformer depends on the application and the type of load connected to it:

1. Metering equipment or instruments, like kW, kVar, A instruments or kWh or kVAh meters, are measuring under normal load conditions. These metering cores require high accuracy, a low burden (output) and a low saturation voltage. They operate in the range of 5-120% of rated current according to accuracy classes:
  - 0.2 or 0.5 for IEC
  - 0.15 or 0.3 or 0.6 for IEEE
2. For protection relays and disturbance recorders information about a primary disturbance must be transferred to the secondary side. Measurement at fault conditions in the overcurrent range requires lower accuracy, but a high capability to transform high fault currents to allow protection relays to measure and disconnect the fault.  
Typical relay classes are 5P, 10P, PR, PX or TP (IEC) or C 100-800 (IEEE).

In each current transformer a number of different cores can be combined. Normally one or two cores are specified for metering purposes and two to four cores for protection purposes.

#### 2.6.2 Metering cores

To protect the instruments and meters from being damaged by high currents during fault conditions, a metering core must be saturated typically between 5 and 20 times the rated current. Normally energy meters have the lowest withstand capability, typically 5 to 20 times rated current.

The rated Instrument Security Factor ( $FS$ ) indicates the overcurrent as a multiple of the rated current at which the metering core will saturate. It is thus limiting the secondary current to  $FS$  times the rated current. The safety of the metering equipment is greatest when the value of  $FS$  is small. Typical  $FS$  factors are 5 or 10. It is a maximum value and only valid at rated burden.

At lower burdens than the rated burden, the saturation value increases approximately to  $n$ :

$$n \approx FS \times \frac{S_n + R_{ct} \times I_{sn}^2}{S + R_{ct} \times I_{sn}^2}$$

where

$S_n$	Rated burden in VA
$S$	Actual burden in VA
$I_{sn}$	Rated secondary current in A
$R_{ct}$	Internal resistance at 75 °C in ohm

To fulfill high accuracy classes (e.g. class 0.2, IEC) the magnetizing current in the core must be kept at a low value. The consequence is a low flux density in the core. High accuracy and a low number of ampere-turns result in a high saturation factor ( $FS$ ). To fulfill high accuracy with low saturation factor the core is usually made of nickel alloyed steel.

NOTE! The accuracy class will not be guaranteed for burdens above rated burden or below 25% of the rated burden (IEC).

With modern meters and instruments with low consumption the total burden can be lower than 25% of the rated burden (see Figure 2.1). Due to turns correction and core material the error may increase at lower burdens. To fulfill accuracy requirements the rated burden of the metering core shall thus be relatively well matched to the actual burden connected. The minimum error is typically at 75% of the rated burden. The best way to optimize the core regarding accuracy is consequently to specify a rated burden of 1.5 times the actual burden.

It is also possible to connect an additional burden, a “dummy burden”, and in this way adapt the connected burden to the rated burden. However, this method is rather inconvenient. A higher output from a core will also result in a bigger and more expensive core, especially for cores with high accuracy (class 0.2).

## 2. How to specify current transformers

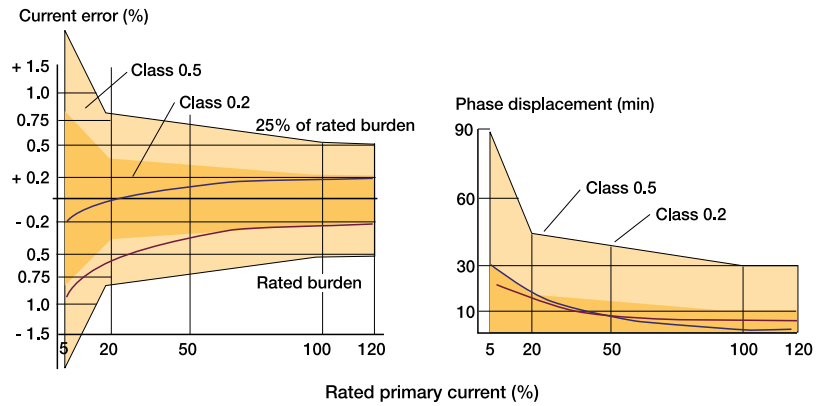

Figure 2.1

Limits for accuracy classes 0.2 and 0.5 according to IEC 60044-1  
with example curves for class 0.5 at different burdens.

### How the ampere-turns influence accuracy

The number of ampere-turns influences the accuracy by increasing the error at lower ampere-turns.

The error ( $\varepsilon$ ) increases:

$$\varepsilon \approx k \times \frac{1}{(AN)^2}$$

where

$k$	Constant
$AN$	Ampere-turns

Also larger core diameter (length of the magnetic path) will also lead to an increase in the error:

$$\varepsilon = k \times L_j$$

where

$L_j$	Length of the magnetic path
-------	-----------------------------

### 2.6.3 Relay cores

Protective current transformers operate in the current range above rated currents. The IEC classes for protective current transformers are typical 5P, 10P, PR and PX.

The main characteristics of these current transformers are:

- Low accuracy (larger errors permitted than for measuring cores)
- High saturation voltage
- Little or no turn correction

The saturation voltage is given by the Accuracy Limit Factor (*ALF*). It indicates the overcurrent as a multiple of the rated primary current up to which the rated accuracy is fulfilled with the rated burden connected. It is given as a minimum value. It can also be defined as the ratio between the saturation voltage and the voltage at rated current. Also the burden on the secondary side influences the *ALF*.

In the same way as for the metering cores, the overcurrent factor *n* changes for relay cores when the burden is changed.

$$n \approx n_{ALF} \times \frac{S_n + R_{ct} \times I_{sn}^2}{S + R_{ct} \times I_{sn}^2}$$

where

$n_{ALF}$	Rated accuracy limit factor
$S_n$	Rated burden in VA
$S$	Actual burden in VA
$R_{ct}$	Internal resistance at 75 °C in ohm
$I_{sn}$	Rated secondary current in A

Note that burdens today are purely resistive and much lower than the burdens several years ago, when electromagnetic relays and instruments were used.

## 2. How to specify current transformers

### 2.6.4 Exciting curve

#### Secondary voltage $E_2$

The secondary induced voltage is:

$$E_2 = \pi \times \sqrt{2} \times A \times B \times N_2 \times f [V]$$

where:

$A$  Core area in  $m^2$

$B$  Flux density in Tesla (T)

$f$  Frequency

$N_2$  Number of secondary turns

$$1 T = 1 Wb / m^2 = 10000 Gauss$$

#### Exciting current $I_o$

The exciting current  $I_o$  is:

$$I_o = \frac{H \times l}{N_2}$$

where:

$H$  Exciting force in At/m

$l$  Length of magnetic path in m

$N_2$  Number of secondary turns

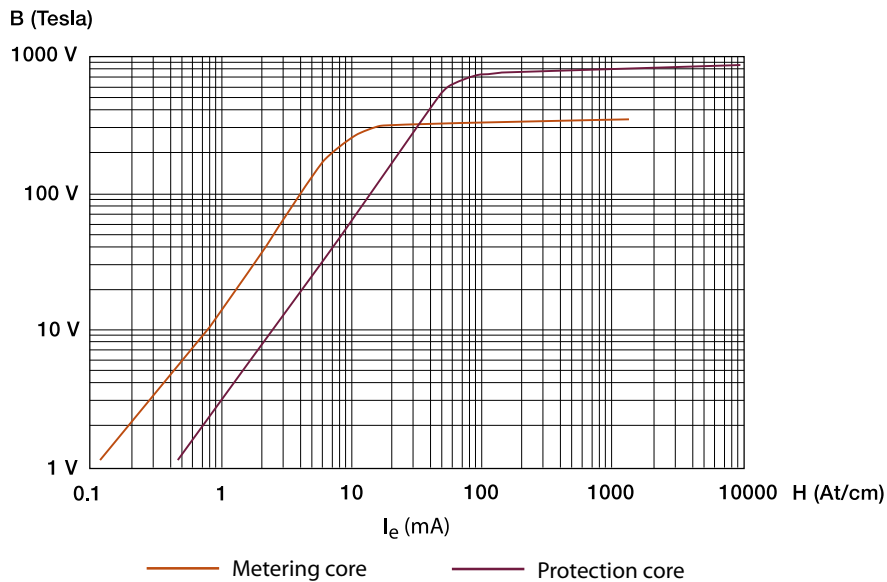

Figure 2.2  
Typical exciting curve for protective and metering cores

### Class PX protective current transformer

A transformer of low leakage reactance for which knowledge of the transformer's secondary excitation characteristics, secondary winding resistance, secondary burden resistance and turns ratio is sufficient to assess its performance in relation to the protective relay system with which it is to be used.

### Rated knee point e.m.f. ( $E_k$ )

The minimum sinusoidal e.m.f. (r.m.s.) at rated power frequency when applied to the secondary terminals of the transformer, all other terminals being open-circuited, which when increased by 10% causes the r.m.s. exciting current to increase by no more than 50%.

Note! The actual knee point e.m.f. will be  $\geq$  the rated knee point e.m.f.

## 2. How to specify current transformers

### 2.6.5 Accuracy classes according to IEC 60044-1

Class	For burdens <sup>1)</sup>	Limits of errors			Application
		at % rated current	Ratio error %	Phase displacement minutes	
0.1	25-100% of rated burden	5	0.4	15	Laboratory
		20	0.20	8	
		100	0.1	5	
		120	0.1	5	
0.2	25-100% of rated burden <15 VA 1VA-100%	5	0.75	30	Precision revenue metering
		20	0.35	15	
		100	0.2	10	
		120	0.2	10	
0.2S <sup>2)</sup>	25-100% of rated burden <15 VA 1VA-100%	1	0.75	30	Precision revenue metering
		5	0.35	15	
		20	0.2	10	
		100	0.2	10	
0.5	25-100% of rated burden	5	1.5	90	Standard commercial metering
		20	0.75	45	
		100	0.5	30	
		120	0.5	30	
0.5S <sup>2)</sup>	25-100% of rated burden	1	1.5	90	Precision revenue metering
		5	0.75	45	
		20	0.5	30	
		100	0.5	30	
		120	0.5	30	

1) PF of secondary burden 0.8 (for 5 VA burden and lower PF = 1.0)

2) Applicable only to transformers having a rated secondary current of 5 A



## 2.6.5 Accuracy classes according to IEC 60044-1 (continued)

Class	For burdens <sup>1)</sup>	Limits of errors			Application
		at % rated current	Ratio error %	Phase displacement minutes	
1.0	25-100% of rated burden	5	3.0	180	Industrial grade meters
		20	1.5	90	
		100	1.0	60	
		120	1.0	60	
3.0	50-100%	50	3.0	-	Instruments
		120	3.0	-	
5.0	50-100%	50	5.0	-	Instruments
		120	5.0	-	
5P and 5PR <sup>3)</sup>	100%	100	1.0	60	Protection
		$ALF \times I_n$	5 <sup>2)</sup>	-	
10P and 10PR <sup>3)</sup>	100%	100	3.0	-	Protection
		$ALF \times I_n$	10 <sup>2)</sup>	-	
PX <sup>4)</sup>	$E_k, I_e, R_{ct}$ <sup>5)</sup>	-	-	-	Protection

1) PF of secondary burden 0.8 (for 5 VA burden and lower PF = 1.0)

2) Composite error

3) Remanence factor ( $K_r$ ) shall not exceed 10% after 3 minutes (see section 3.4.3)

4) Rated knee point e.m.f. ( $E_k$ ). The minimum sinusoidal e.m.f. (r.m.s.) at rated power frequency when applied to the secondary terminals of the transformer, all other terminals being open-circuited, which when increased by 10% causes the r.m.s. exciting current to increase by no more than 50%.

Note! The actual knee point e.m.f. will be  $\geq$  the rated knee point e.m.f.

5)  $R_{ct}$  = CTs secondary resistance at 75 °C.

## 2. How to specify current transformers

### 2.6.6 Accuracy classes according to IEEE C57.13

Class	Error limits (the limits are valid for any of the standard burdens below)					
	Times rated current	Power error %	Designation	Ohm	PF	Application
0.15	1.0	0.15				High-accuracy metering
	0.05	0.30				
0.15S	1.0	0.15	B-0.1	0.1	0.9	
	0.05	0.15	B-0.2	0.2		
0.3	1.0	0.3	B-0.5	0.5	0.9	
	0.1	0.6	B-0.9	0.9		
0.6	1.0	0.6	B-1.8	1.8		Metering
	0.1	1.2				
1.2	1.0	1.2				
	0.1	2.5				

Class	Times rated current	Ratio error %		Secondary terminal voltage	Designation	PF	Application
		Rated current	Low rated current				
C100 <sup>1)</sup> T100	20	3	10	100	B-1.0		
C200 T200	20	3	10	200	B-2.0		
C400 T400	20	3	10	400	B-4.0	0.5	Protection
C800 T800	20	3	10	800	B-8.0		
X	-	1	-	$E_s, J_e, R_{ct}$ <sup>2)</sup>			

1) C = Calculated, T = Tested. Valid for CTs in which the leakage flux in the core of the transformer has an appreciable effect on the ratio.

2) Rated knee point voltage  $E_s$ ; specified in IEEE C57.13 -2008 6.10.2

Class C is used for cores with evenly distributed winding, i.e. when the leakage flux is negligible (valid for all ABB CTs).

#### Extended Range Metering Capabilities

Metering range for metering classes (IEEE C57.13) cover 10% to 100% of the rated current. It is not always satisfactory for revenue and precision metering. However, it is possible to extend the metering range i.e. from 1% to 150%. Note that the metering range must be specified separately. A better accuracy class 0.15 will sometimes be required. Normally, the manufacturer will have no problem meeting the requirements. At lower rated currents there may be problems fulfilling the accuracy in the extended range.

**Comparison between IEC 60044-1 and IEEE C57.13 relay cores:**

For example in class C800 the secondary terminal voltage  $U_t$  is 800. The transformer will deliver this voltage to a standard burden  $Z_b$  of 8 ohms at 20 times ( $n$ ) the rated secondary current  $I_{ns}$  of 5 A, so then 100 A at 20 times  $I_{ns}$ .

$$U_t = n \times I_{ns} \times Z_b$$

$$U_t = 20 \times 5 \times 8$$

$$U_t = 800 \text{ V}$$

The burden is generally given in ohms ( $Z_b$ ) in IEEE and CAN but in VA ( $S_b$ ) in IEC.

$$S_b = Z_b \times I_{ns}^2$$

$$S_b = 8 \times 5^2$$

$$S_b = 200 \text{ VA}$$

In IEC 60044-1 the corresponding classes are roughly estimated to be:

- C800 ~ 200 VA class 10P20
- C400 ~ 100 VA class 10P20
- C200 ~ 50 VA class 10P20
- C100 ~ 25 VA class 10P20

For 1 A rated secondary current, the secondary voltage will be 5 times higher than for 5 A. In IEEE 5 A is the standard value.

## 2. How to specify current transformers

### 2.7 Pollution levels

For outdoor current transformers with ceramic insulators susceptible to contamination, the creepage distances according to IEC 60815-1; -2; -3 2008-10 for different pollution levels are:

Pollution level		Unified Specific Creepage Distance USCD (phase-ground voltage) mm/kV
a	Very light	22
b	Light	28
c	Medium	35
d	Heavy	44
e	Very Heavy	54

### Silicone insulators

In cases of exceptional pollution severity silicone rubber insulators can be used instead of ceramic insulators. Due to the chemical nature of silicone the insulator surface is hydrophobic (non-wetting). Water on the surface stays as droplets and does not form a continuous water film. The leakage currents are suppressed and the risk of flashover is reduced compared to porcelain and other polymeric materials. Silicone rubber has the unique ability to maintain its hydrophobicity during the lifetime of the insulation. The mechanism behind the hydrophobicity of silicone rubber is the diffusion of low molecular weight (LMW) silicones to the surface, where they spread out and form a hydrophobic layer. They also have the ability to encapsulate contaminant particles. Washing is normally not needed.

As an alternative to the use of silicone rubber insulators the practicability of regular washing of porcelain insulators can be considered.

The salt-fog test to IEC 60507 demonstrated that, assuming the same salinity in each case, the creepage paths required for silicone insulation are, on average, 30 % shorter than the paths necessary with ceramic insulators.

IEC 60815-1; -2; -3 describes selection and dimensioning of high voltage insulators for use in polluted conditions.

## 3. Measurement of current during transient conditions

### 3.1 Background

During the last decades the demands on current transformers for protection has increased rapidly. Overcurrents in power networks and also time constants for the short-circuit d.c. offset are increasing. Very short breaker tripping times are stipulated and achieved by fast operating protective relay systems. The relays must perform measurements at a time when the transient (d.c. offset) has not yet died down. A normal protective core in a current transformer will saturate very rapidly due to high currents and remanent flux. After saturation occurs, the current transformer output will be distorted and the performance of the relay protection system will be affected. For protection relays intended to operate during a fault the core output under transient conditions is of importance.

### 3.2 The network

Earlier we analyzed the measuring of currents during symmetrical conditions. During transient conditions, the fault current consists of the symmetrical a.c. short-circuit current and a d.c. offset which rapidly saturates on an ordinary relay core, e.g. within 2 - 5 ms.

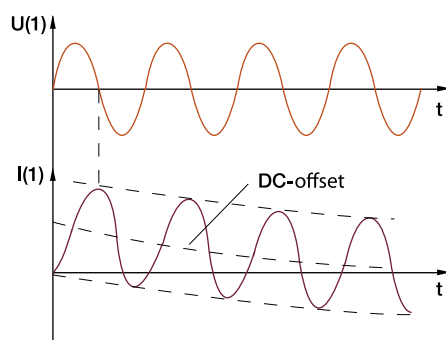

Figure 3.1  
DC offset

Figure 3.1 shows the voltage and the short-circuit current with its d.c. offset. The impedance is mainly inductive in a network and the phase angle is  $\sim 90^\circ$  between the voltage and the current during short-circuit conditions. A 100% d.c. offset can be achieved only if the fault occurs in the very moment when the voltage is zero. A normal type of fault is a flash-over, which can occur only when the voltage is around maximum. The only possible occasion for a 100% d.c. offset to occur is when the fault is a solid short-circuit or solid grounded line and located near to the generator station. Direct lightning strikes can also give qualification for a 100% d.c. offset.

### 3. Measurement of current during transient conditions

The time before the d.c. offset runs out depends on the network's time constant  $T_p$  and

$$T_p = \frac{L}{R}$$

where

$L$  Network inductance

$R$  Network resistance

System voltage	Typical time constant $T_p$
100 - 360 kV	Up to 100 ms but typically less than 50 ms
380 - 500 kV	Up to 150 ms but typically less than or equal to 80 ms
> 500 kV	Varying but typically 100 - 150 ms

Close to transformers the time constant will increase compared to the above values.

Standard values for rated primary time constant ( $T_p$ )

Standard values, expressed in milliseconds, are:

40	60	80	100	120
----	----	----	-----	-----

**NOTE!** For some applications, higher values of rated primary time constant may be required. Example: large turbo-generator circuits.

The time constant does not have the same value throughout the complete network, in a substation each incoming line may have different values. It should be noted that high values of the primary time constant not only occur close to the generation source but also close to low load loss power transformers which can give a high primary time constant. With a transmission line between the generator and the location of the current transformer, the resistance of the line reduces the time constant considerably. Many utilities specify the same time constant for the whole network, which means that the value is often too high. A reduced time constant does not only result in a reduced short-circuit current, but also in a significant reduction in required core area.

In a power network the short-circuit current will flow until the fault is cleared by means of a power circuit breaker. It is the duty of the current transformer to supply the protective systems with a current that is a correct reproduction of the primary current during a time that is sufficient to allow operation of the protective relays. Relay operating time may be 10 - 50 ms and breaker operation time 40 - 80 ms. This gives a typical fault clearing time of 80 - 120 ms.

Current transformers which are to measure a complete fault current with 100% d.c. offset will be very large and sometimes their cores will have absurd dimensions. Figure 3.2 shows an example of how the flux develops in the current transformer.

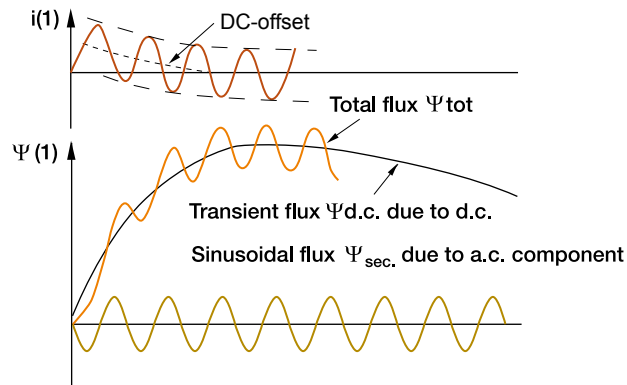

Figure 3.2  
Effect of d.c. offset of primary fault current on flux demands of a current transformer core

Figure 3.3 shows an example of the distortion of the secondary current due to saturation in the core.

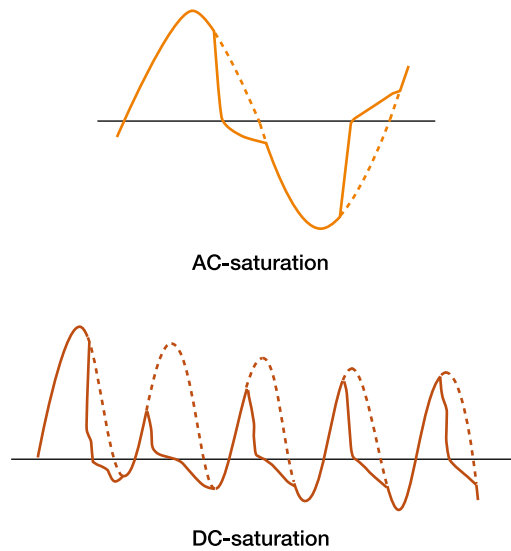

Figure 3.3  
Distortion in secondary current due to saturation

### 3.3 Important parameters

#### 3.3.1 Rated primary current ( $I_{pn}$ )

Maximum continuous current to be rounded off to the nearest standard value.

## 3. Measurement of current during transient conditions

### 3.3.2 Rated secondary current ( $I_{sn}$ )

Common standard value is 1 or 5 A. It is much easier to maintain the external burden at a low value when using 1 A. We assume that the external burden is resistive 1 ohm ( $Z_b$ ) and the burden in VA is

$$S = I_{sn}^2 \times Z_b$$

where

$S$  25 VA for a rated secondary current of 5 A

$S$  1 VA for a rated secondary current of 1 A

The core size is proportional to the rated burden. Therefore, the preferred secondary rated current for outdoor switchgear is 1 A. 5 A is more applicable in indoor switchgear with short wiring.

### 3.3.3 Rated primary symmetrical short-circuit current ( $I_{psc}$ )

The RMS value of primary symmetrical short-circuit currents (AC). It is important that the actual level is specified. A high short-circuit current in combination with low rated current results in low ampere-turns and large cores.

### 3.3.4 Secondary burden ( $R_b$ )

For transient cores the secondary burden must always have a low value, e.g. 5-10 VA. The power factor is 1 (resistive).

Standard values of rated resistive burden ( $R_b$ ) in ohms for class TP (IEC) current transformers based on a rated secondary current of 1 A are:

2.5	5	7.5	10	15
-----	---	-----	----	----

The preferred values are marked with grey. For current transformers having a rated secondary current other than 1 A, the above values should be adjusted in inverse ratio to the square of the current.

### 3.3.5 Specified duty cycle (C-O and C-O-C-O)

During each specified energization, the primary energizing current shall be assumed to be "fully offset" from the specified primary time constant ( $T_p$ ) and be of rated amplitude ( $I_{psc}$ ).



The accuracy must be maintained during a specified duty cycle, which can be either single or double:

The single duty cycle is described as C-t'-O, meaning Close - duration of current flow - Open. The duration of the current flow (t') can be substituted with t'<sub>al</sub> meaning that the accuracy only needs to be maintained for a shorter time than t'. The time t' is due to the relay operation time

The double duty cycle is described as C-t'-O-t<sub>fr</sub>-C-t''-O meaning Close - duration of first current flow - Open - dead time - Close - duration of second current flow - Open. The duty cycle is described as an auto-reclosing operation, which is very common in network operation. The time t' and t'' are due to relay and circuit breaker operation time during the reclosure. They can be substituted by t'<sub>al</sub> and / or t''<sub>al</sub> in the same way as for the single duty cycle. The dead time or fault repetition time t<sub>fr</sub> is the time interval between interruption and re-application of the primary short-circuit current during a circuit breaker auto-reclosure duty cycle.

### 3.3.6 Secondary-loop time constant ( $T_s$ )

The value of the time constant of the secondary loop of the current transformer including the magnetizing inductance ( $L_s$ ), winding resistance ( $R_s$ ) and leakage inductance with rated burden connected to the secondary terminals.

$$T_s = \frac{L_s}{R_s}$$

Typical secondary time constants are for

TPX core 5 - 20 seconds (no air gaps)

TPY core 0.5 - 2 seconds (small air gaps)

TPZ core ~ 60 msec. (phase displacement 180 min.+/- 10%) (large air gaps)

Air gaps in the core give a shorter  $T_s$ .

### 3.3.7 Rated symmetrical short-circuit current factor ( $K_{ssc}$ )

Ratio 
$$K_{ssc} = \frac{I_{psc}}{I_{pn}}$$

$I_{psc}$  r.m.s. value of primary symmetrical short-circuit current

$I_{pn}$  Rated primary current

## 3. Measurement of current during transient conditions

### 3.3.8 Rated transient dimensioning factor ( $K_{td}$ )

A transient core has to be heavily oversized compared to a conventional protection core. A transient factor ( $K_{tf}$ ) is determined with respect to the primary and secondary time constants for a fully offset short-circuit after  $t$  seconds. The rated transient dimensioning factor  $K_{td}$ , where the specified duty cycles are taken into account, is derived from this factor. It is shown on the rating plate of the current transformer.

### 3.3.9 Flux overcurrent factor ( $n_f$ )

The secondary core will be designed on the basis of the  $K_{ssc}$  (AC-flux) and  $K_{td}$  (DC-flux).

$$n_f = K_{ssc} \times K_{td}$$

Typical value of  $K_{td}$  is 10 - 25.

ABB will design the cores to find the optimum solution.

For special measurement of fault current (transient current,) including both a.c. and d.c. components, IEC 60044-6 defines the accuracy classes TPX, TPY and TPZ.

The cores must be designed according to the transient current:

- TPX cores have no requirements for remanence flux and have no air gaps. High remanence CT.
- TPY cores have requirements for remanence flux and are provided with small air gaps. Low remanence CT.
- TPZ cores have specific requirements for phase displacement and the air gaps will be large. Non remanence CT.

### 3.3.10 Maximum instantaneous error

$$\epsilon = \frac{I_{al}}{I_{psc} \times \sqrt{2}} \times \frac{N_s}{N_p} \times 100$$

$I_{psc}$  Rated primary symmetrical short-circuit current

$I_{al}$  Accuracy limiting secondary current

$N_s$  Secondary turns

$N_p$  Primary turns

### 3.4 Air gapped cores

#### 3.4.1 Remanent flux ( $\Psi_r$ )

That value of which flux would remain in the core three minutes after the interruption of an excitation current of sufficient magnitude as to induce the saturation flux  $\Psi_s$ .

The remanent flux of ungapped current transformers can be as high as 80% of the saturation flux, see Figure 3.5.

#### 3.4.2 Remanence factor ( $K_r$ )

$$K_r = \frac{\Psi_r}{\Psi_s}$$

where

$\Psi_s$  Saturation flux: That peak value of the flux which would exist in a core in the transition from the non-saturated to the fully saturated condition and deemed to be that point on the B-H characteristic for the core concerned at which a 10% increase in B causes H to be increased by 50%.

$\Psi_r$  Remanent flux

Maximum value of TPY and PR cores is 0.1 after 3 minutes.

Small air-gaps in the core can be shown to reduce the value of remanent flux to a negligible value, see Figure 3.5. In this case the characteristic exciting curve of the current transformer is mainly determined by the characteristics of the air-gap itself up to saturation level. The width of the required gap is critical and caution should be exercised in the construction of the current transformer to ensure that the gap will remain constant.

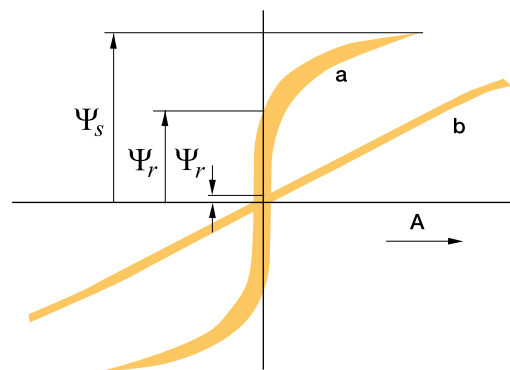

Figure 3.4  
Hysteresis curves of a current transformer  
a) without air-gap | b) with air-gap

### 3. Measurement of current during transient conditions

The exciting inductance  $L_s$  of a gapped CT is more linear than in the case of an ungapped core, and a secondary time constant  $T_s$  can be defined by:

$$T_s = \frac{L_s}{R_{ct} + R_b}$$

where

$R_{ct}$  Secondary resistance of the CT

$R_b$  Connected external resistance (burden)

The determination of exciting inductance  $L_s$  from routine tests for exciting characteristics provides a means of controlling the gap width. A tolerance of +/- 30% is allowed for class TPY transformers according to IEC 60044-6.

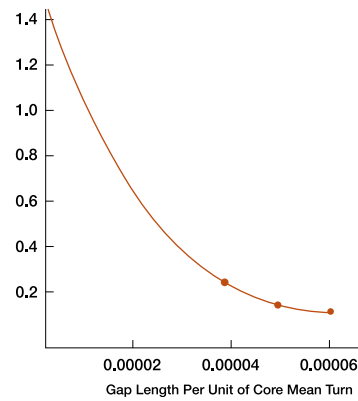

Figure 3.5

Typical relation between residual flux and air gap for electrical sheet steel

#### 3.5 Accuracy classes for transient cores according to IEC 60044-6

##### 3.5.1 Error limits for TPX, TPY and TPZ current transformers

With the secondary resistance adjusted to rated values ( $R_s = R_{ct} + R_b$ ) the errors shall not exceed the values given in the table below:

Accuracy class	At rated primary current			At accuracy limit condition
	Current error %	Phase displacement Minutes	Phase displacement Centiradians	Maximum instantaneous error %
TPS	See 3.5.2	-	-	$\epsilon = 5$
TPX	$\pm 0.5$	$\pm 30$	$\pm 0.9$	$\epsilon = 10$
TPY	$\pm 1.0$	$\pm 60$	$\pm 1.8$	$\epsilon = 10$
TPZ	$\pm 1.0$	$180 \pm 18$	$5.3 \pm 0.6$	$\epsilon_{ac} = 10$

### 3.5.2 Error limits for TPS current transformers

The primary/secondary turns ratio error shall not exceed  $\pm 0.25\%$ . The accuracy limiting conditions are defined by the exciting characteristic and the secondary accuracy limiting voltage  $U_{al}$  shall not be less than the specified value. The value shall be such that an increase of 10% in magnitude does not result in an increase in the corresponding peak instantaneous exciting current exceeding 100%.

When specified by the purchaser, the measured value of the peak exciting current at the accuracy limiting voltage shall not exceed the specified value. If no limit is set, the exciting current shall in any case not exceed that value corresponding to an error class of 5% of  $I_{th}$  for the secondary side.

The accuracy limit voltage defined by the purchaser is generally expressed as follows:

$$U_{al} > K \times K_{ssc} \times (R_{ct} + R_b) \times I_{sn}$$

in which  $K$  is the dimensioning factor assigned by the purchaser.  $R_{ct}$  is defined by the manufacturer's design, except for certain applications where limits may need to be set by the purchaser to enable co-ordination with other equipment.

### 3.6 How to specify current transformers for transient performance

First it must be decided which type of transformer is specified. If there are requirements regarding the remanence factor (usually  $K_r < 10\%$ ) it is clear that the core must have air-gaps. If there is no requirement for low remanence we would probably choose a TPX-core, as long as the specified transient duty cycle contains only a single energization. With a double duty-cycle the TPX core would be saturated much too fast during the second energization.

With a remanence factor of less than 10% the choice stands between class TPY and TPZ as they are both designed with air-gaps. The difference between the two classes is that the TPZ core cannot accurately reproduce the d.c. component in the short-circuit current, and therefore the instantaneous current error can only take the alternating current component into account. The TPY-core has a smaller air-gap and it is possible to have a criterion for the total instantaneous error current.

As transient cores are heavily oversized it is important that the specified parameters are as accurate as possible. The following data is to be submitted to the manufacturer, depending on the selected accuracy class, see also Chapter 9, Protective relays.

### 3. Measurement of current during transient conditions

Current transformer class	TPS	TPX	TPY	TPZ
Rated primary current ( $I_{pn}$ )	X	X	X	X
Rated secondary current ( $I_{sn}$ )	X	X	X	X
Rated frequency	X	X	X	X
System voltage and insulation level	X	X	X	X
$I_{th}$ ( $I_{psc}$ )	X	X	X	X
$I_{dyn}$	X	X	X	X
Ratio to which specified data applies	X	X	X	X
$K_{ssc}$	X	X	X	X
$K_{td}$	-	X	X	X
$T_p$	-	X	X	X
$T_s$	-	-	X	-
% DC-offset	-	X	X	X
Duty cycle:				
Single: $t'$ , $t'_{al}$	-	X	X	-
Double: $t'$ , $t'_{al}$ , $t_{fr}$ , $t''$ , $t''_{al}$				
$R_b$	X	X	X	X
$K$	X	-	-	-
Maximum $I_{al}$ at $U_{al}$	X	-	-	-
$R_{ct}$	X	-	-	-

$I_{th}$	Short-time current (fault current)
$I_{dyn}$	Dynamic current (peak)
$K_{ssc}$	$I_{psc}/I_{pn}$
$T_p$	Primary time constant
$T_s$	Secondary time constant
$t'_{al}$	Permissible time to accuracy limit
$t_{fr}$	Dead time (during reclosing)
$R_b$	Resistive burden
$K$	Dimensioning parameter assigned by the purchaser
$I_{al}$	Exciting current
$U_{al}$	Knee point voltage
$R_{ct}$	Secondary CT resistance at 75°C
$K_{td}$	Transient dimensioning factor

## 4. How to specify voltage transformers

Important main factors when selecting voltage transformers:

- Standard (IEC, IEEE or national)
- Inductive or capacitor voltage transformers
- Insulation level (service voltage)
- Altitude above sea level (if >1000 m)
- Rated primary voltage
- Rated secondary voltage
- Ratio
- Rated voltage factor
- Burdens (outputs) and accuracy for each winding
- Pollution levels (creepage distance)

### 4.1 Type of voltage transformer

Voltage transformers can be split up into two groups, namely inductive voltage transformers and capacitor voltage transformers (CVT).

Inductive voltage transformers are most economical up to a system voltage of approximately 145 kV and capacitor voltage transformers above 145 kV.

There are two types of capacitor voltage transformers on the market: high and low capacitance types. With requirements on accuracy at different operation conditions, such as pollution, disturbances, variations of the frequency temperature and transient response, the high capacitance type is the best choice.

A capacitor voltage transformer can also be combined with PLC-equipment for communication over the high-voltage transmission line, also for voltages lower than 145 kV.



Inductive voltage transformer  
ABB type EMF for 145 kV



Capacitive voltage transformer  
ABB type CPA for 420 kV

## 4. How to specify voltage transformers

### 4.2 Rated insulation level

#### 4.2.1 Rated insulation levels according to IEC

For inductive voltage transformers IEC 61869-1:

Maximum System voltage kV	Power frequency withstand voltage		Lightning impulse withstand voltage kV	RIV test voltage kV	Maximum RIV level $\mu\text{V}$	PD test voltage kV *)	Maximum PD level pC
	Dry kV	Wet kV					
24	50	50	125	-	-	29	10
36	70	70	170	-	-	43	10
52	95	95	250	-	-	62	10
72.5	140	140	325	-	-	87	10
82.5	150	150	380	-	-	99	10
123	230	230	550	78	2500	148	10
145	275	275	650	92	2500	174	10
170	325	325	750	108	2500	204	10
245	460	460	1050	156	2500	294	10

\*) Test voltage for isolated or non-effectively earthed neutral systems (voltage factor > 1.5), for earthed neutral systems (voltage factor 1.5) the test voltage is  $U_m$ .  
Test voltages apply at  $\leq 1000$  m above sea level.

For capacitor voltage transformers IEC 61869-1:

Maximum System voltage kV	Power frequency withstand voltage		Lightning impulse withstand voltage kV	Switching impulse withstand voltage kV	RIV test voltage kV	Maximum RIV level $\mu\text{V}$	PD test voltage kV *)	Max. PD level pC
	Dry kV	Wet kV						
72.5	140	140	325	-	-	-	87	10
123	230	230	550	-	78	2500	148	10
145	275	275	650	-	92	2500	174	10
170	325	325	750	-	108	2500	204	10
245	460	460	1050	-	156	2500	294	10
300	460	-	1050	850	190	2500	360	10
362	510	-	1175	950	230	2500	435	10
420	630	-	1425	1050	267	2500	420*	10
550	680	-	1550	1175	333	2500	550*	10
800	975	-	2100	1550	486	2500	800*	10

\*) Earthed neutral system.  
Test voltages apply at  $\leq 1000$  m above sea level.



#### 4.2.2 Basic insulation levels according to IEEE/ANSI

For inductive voltage transformers IEEE C57.13 -2008 is applicable:

Maximum system voltage kV	Power frequency withstand voltage		Lightning impulse withstand voltage kV	RIV test voltage kV	Max. RIV level μV
	Dry kV	Wet kV			
25.5	50	50	150	-	-
36.5	70	70	200	21	50
48.3	95	95	250	28	50
72.5	140	140	350	42	50
123	230	230	550	70	50
145	275	275	650	84	50
170	325	315	750	98	50

Test voltages apply at ≤ 1000 m above sea level.

For capacitor voltage transformers IEEE C57.13 -2008:

Maximum system voltage kV	Power frequency withstand voltage		Lightning impulse withstand voltage kV	Switching impulse withstand voltage kV	RIV test voltage kV	Maximum RIV level μV
	Dry kV	Wet kV				
72.5	165	140	350	-	42	125
123	265	230	550	-	70	250
145	320	275	650	-	84	250
170	370	325	750	-	98	250
245	460	445	1050	-	140	250
362	575	680	1300	825	209	250
550	800	780	1800	1175	318	500
800	920	1050	2050	1425	462	750

Test voltages apply at ≤ 1000 m above sea level

For installation at an altitude higher than 1000 m above sea level, apply a correction factor in the same way as described for current transformers in chapter 9.1.

#### 4.3 Rated primary and secondary voltage

The performance of the transformer is based on its rated primary and secondary voltage.

Voltage transformers for outdoor applications are normally connected between phase and ground. The standard values of rated primary voltage are  $1/\sqrt{3}$  times of the value of the rated system voltage.

The rated secondary voltage is chosen according to local practice; in European countries often  $100/\sqrt{3}$  V or  $110/\sqrt{3}$  V.

## 4. How to specify voltage transformers

Wherever possible, the chosen voltage ratio shall be one of those stated in the standards. If, for some reason, a special ratio must be chosen, the ratio factor should be of a simple value (100, 200, 300, 400, 500, 600, 1000, 2000 and their multiples).

As can be seen from Figure 1.7 the variation of accuracy within a wide range of voltages is very small. The transformers will therefore supply a secondary voltage at good accuracy even when the primary voltage varies considerably from the rated voltage. A check must, however, be made for the connected metering and relaying equipment, to ensure that they operate satisfactorily at the different voltages.

The normal measuring range of a voltage transformer is for the metering winding 80-120% of the rated voltage. The relay winding has a voltage range from 0.05 to 1.5 or 1.9 of the rated voltage.

### 4.4 Rated voltage factor

Voltage transformers, both inductive and capacitor types are usually connected phase to earth. In the event of a disturbance in a three-phase network, the voltage across the voltage transformer may sometimes be increased even up to the voltage factor,  $V_f$  times the nominal rated performance voltage.

IEC specifies the voltage factors:

- 1.9 for systems not being solidly earthed
- 1.5 for systems with solidly earthed neutral.

The duration is specified to be 30 seconds if automatic fault tripping is used during earth faults, in other cases 8 hours. Because of the above-mentioned requirement the voltage transformers operate with low flux density at rated voltage.

The voltage transformer core must not be saturated at the voltage factor.

### 4.5 Burdens and accuracy classes

As for the current transformers the accuracy is divided into classes for measuring and classes for protection purposes.

For revenue metering, it is important that the transformer is measuring correctly at different temperatures. An inductive voltage transformer has negligible deviations at different temperatures, while capacitor voltage transformers with a dielectric consisting only of paper or polypropylene film show large variations due to changes in capacitance. In a modern capacitor voltage transformer the dielectric consists of two different types of material, paper and polypropylene, which have opposite temperature characteristics and thus combined give a minimum of deviation. The deviation is about the same magnitude as that of an inductive voltage transformer.

On a voltage transformer provided with more than one secondary winding, these windings are not independent of each other, as in the case of a current transformer with several secondary windings each on their own core. The voltage drop in the primary winding of a voltage transformer is proportional to the total load current in all secondary windings. Measuring and protective circuits can therefore not be selected independently of each other.

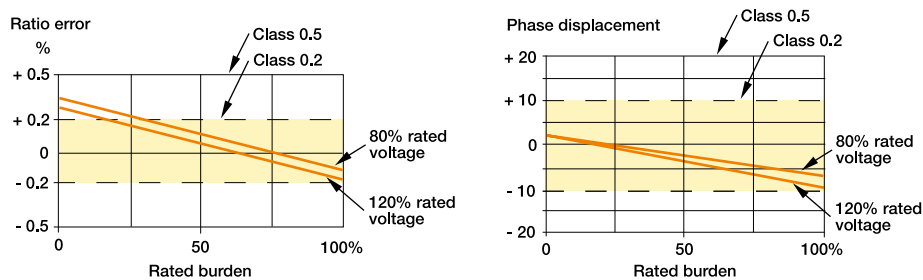

Figure 4.1

Typical error curves and limits for classes 0.2 and 0.5 according to IEC 60044-2

The accuracy class and rated burden are normally selected as follows:

- When the burden consists of metering and relaying components, the higher accuracy class required for metering must be selected.
- The burden requirements must be equivalent to the total burden of all the equipment connected to the voltage transformer. For example:
 

Metering equipment	25 VA
Accuracy class	0.5
Relays	100 VA
Accuracy class	3P
- The voltage transformer selected should then be able to supply 125 VA at an accuracy corresponding to class 0.5.
- The above is valid provided that the relays consume the 100 VA connected continuously in regular service. If the relay circuits are loaded only under emergency conditions, their influence on the metering circuits can be neglected.

The metering classes of IEC 60044-2 are valid for 80-120% of rated voltage and 25-100% of rated burden.

The protective classes are valid from 5% to  $V_f$  times rated voltage and for 25-100% of rated burden ( $V_f$  = voltage factor, see above).

It shall be noted that a voltage transformer winding can be given a combined class, i.e. 0.5/3P, which means that metering accuracy is fulfilled for 80-120% of rated voltage, and, additionally, the accuracy and transient response requirements for the protection class are fulfilled between 5% - 80% and 120% -  $V_f$  times rated voltage.

## 4. How to specify voltage transformers

When more than one secondary winding is required, it must be clearly specified how the burdens and classes shall apply.

- For one winding, with the other windings unloaded, or
- With all windings loaded simultaneously.

Note that different secondary windings of a voltage transformer are dependent of each other.

The thermal burden of a voltage transformer is equivalent to the total power the transformer can supply without exceeding the specified temperature rise, taking into consideration the voltage factor.

### Burdens lower than 25% of rated burden

According to IEC 60044-2 and some other standards, the accuracy class shall be fulfilled from 25% to 100% of the rated burden.

Modern meters and instruments have low power consumption and the total burden can be lower than 25% of the rated burden (see Figure 4.1). Due to correction of turns the error will increase at lower burden. Minimum error is typically at 75% of the rated burden.

The best way is specify a rated burden of 1.5 times the actual connected burden. The voltage transformer will be designed with regard to this requirement.

Accuracy classes according to IEC 60044-2:

Class	Range		Limits of errors		Application
	Burden %	Voltage %	Ratio %	Phase displacement Minutes	
0.1	25-100	80-120	0.1	5	Laboratory
0.2	25-100 <10VA 0-100% PF=1	80-120	0.2	10	Precision and revenue metering
0.5	25-100	80-120	0.5	20	Standard revenue metering
1.0	25-100	80-120	1.0	40	Industrial grade meters
3.0	25-100	80-120	3.0	-	Instruments
3P	25-100	5-Vf *)	3.0	120	Protection
6P	25-100	5-Vf *)	6.0	240	Protection

\*) Vf = Voltage factor

### Standard values of rated output

The standard values of rated output at a power factor of 0.8 lagging, expressed in volt-amperes, are:

10	15	25	30	50	75	100	150	200	300	400	500 VA
----	----	----	----	----	----	-----	-----	-----	-----	-----	--------

The values marked with color are preferred values. The rated output of a three-phase transformer shall be the rated output per phase.

### Accuracy classes according to IEEE C57.13

Class	Range		Power error at metered load PF 0.6-1.0 %	Application
	Burden %	Voltage %		
0.15	0-100	90-110	0.15	High-accuracy metering
0.3	0-100	90-110	0.3	Revenue metering
0.6	0-100	90-110	0.6	Standard metering
1.2	0-100	90-110	1.2	Relaying
1.2R	0-100	90	1.2	Relaying CCVT
		25	3	
		5	5	
Standard burdens		VA	PF	
M		35	0.20	
W		12.5	0.10	
X		25	0.70	
Y		75	0.85	
Z		200	0.85	
ZZ		400	0.85	

### 4.6 Pollution levels

The effects of pollution on voltage transformer insulators are the same as described for current transformers in chapter 2.7.

### 4.7 Transient response for capacitor voltage transformers

When a primary short-circuit occurs, the discharge of the energy stored in the capacitive and inductive elements of the transformer will result in a transient voltage oscillation on the secondary side. This transient is normally a combination of one low frequency oscillation of 2-15 Hz and one high frequency oscillation that can lie between 900 to 4000 Hz. The high frequency part of this is damped out within short time, normally within 10 ms, whereas the low frequency part lasts longer. The amplitudes of the transient are determined by the phase angle of the primary voltage at the moment of the short-circuit. Higher capacitance gives lower amplitude on the low frequency oscillation.

## 4. How to specify voltage transformers

### Standard recommendations and requirements

The different standards specify certain requirements as to what can be accepted after a short-circuit occurring directly on the terminals. The secondary voltage must not be higher than a specified value at a certain time after the primary short-circuit. IEC, class T1 for instance, specifies a secondary amplitude value not higher than 10% of the secondary voltage before the short-circuit within a time equivalent to one period of the rated frequency.

Class T2 and T3 has demands for lower values of amplitude and duration. Those classes require damping devices and may give malfunction of the relays.

Other standards also require that all frequencies of the transient shall be outside (higher or lower) the limits set by a certain specified frequency band.

### Transient response classes according to IEC 60044-5

Time $T_s$ (seconds)	Ratio $\frac{ U_s(t) }{\sqrt{2} \cdot U_s} \cdot 100\%$		
	Classes 3PT1 6PT1	Classes 3PT2 6PT2	Classes 3PT3 6PT3
$10 \cdot 10^{-3}$	-	$\leq 25$	$\leq 4$
$20 \cdot 10^{-3}$	$\leq 10$	$\leq 10$	$\leq 2$
$40 \cdot 10^{-3}$	$< 10$	$\leq 2$	$\leq 2$
$60 \cdot 10^{-3}$	$< 10$	$\leq 0.6$	$\leq 2$
$90 \cdot 10^{-3}$	$< 10$	$\leq 0.2$	$\leq 2$

NOTE 1: For a specified class the transient response of the secondary voltage  $U_s(t)$  can be aperiodic or periodic damped and a reliable damping device can be used.

NOTE 2: Capacitor voltage transformer. For transient response classes 3PT3 and 6PT3, needs the use of a damping device.

NOTE 3: Other values of the ratio and the time  $T_s$  can be agreed between manufacturer and purchaser.

NOTE 4: The choice of transient response class depends on characteristics of the specified protection relays.

If a damping device is used, the proof of the reliability of this device should be part of an agreement between manufacturer and purchaser.

#### 4.8 Transient response for inductive voltage transformers

In an inductive voltage transformer only the fast high frequency oscillation lapse occurs. The dominating low frequency lapse in the capacitor voltage transformer does not occur since there are no capacitors in the inductive voltage transformers.

#### 4.9 Ferroresonance

Ferroresonance is a potential source of transient overvoltage. Three-phase, single-phase switching, blown fuses, and broken conductors can result in overvoltage when ferroresonance occurs between the exciting impedance of a transformer and the system capacitance of the isolated phase or phases. For example, the capacitance could be as simple as a length of cable connected to the ungrounded winding of a transformer. Another example of ferroresonance occurring is when an inductive voltage transformer is connected in parallel with a large grading capacitor across the gap of a circuit breaker.

Ferroresonance is usually known as a series resonance.

#### 4.10 Ferroresonance in capacitor voltage transformers

Ferroresonance may occur in circuits containing a capacitor and a reactor incorporating an iron core (a non-linear inductance). A capacitor voltage transformer with its capacitor divider and its intermediate voltage transformer with non-linear exciting characteristics is such a circuit.

The phenomenon may be started if the core of the intermediate voltage transformer for some reason happens to be saturated. For example during a switching operation. A resonance oscillation, normally having a frequency lower than the normal 50-60 Hz, may then be initiated and superposed on the normal frequency voltage and may last a long time if it is not efficiently damped.

#### Damping of ferroresonance

A ferroresonance oscillation, which is not damped out efficiently, is dangerous for the transformer. Under such circumstances the core of the intermediate voltage transformer works at full saturation and the exciting current might be large, so that there is a risk of a failure. A damping arrangement that damps any resonance oscillations effectively is thus a necessity. The standards specify certain requirements on the damping and these tests should be performed in order to verify that these are fulfilled.

## 4. How to specify voltage transformers

### 4.11 Ferroresonance in inductive voltage transformers

When the ferroresonance in a capacitor voltage transformer is an internal oscillation between the capacitor and the inductive intermediate voltage transformer, the ferroresonance in an inductive voltage transformer is an oscillation between the inductive voltage transformer and the network. The oscillation can only occur in a network having an insulated neutral. An oscillation can occur between the network's capacitance to ground and the non-linear inductance in the inductive voltage transformer. The oscillation can be triggered by a sudden change in the network voltage.

It is difficult to give a general figure of a possible risk of ferroresonance, as it depends on the design of the transformer. We can roughly calculate that there will be a risk of resonance when the zero-sequence capacitance expressed in  $S$  km transmission line is

$$S > \frac{42000}{U_n^2} [km]$$

$U_n$  System voltage (phase - phase voltage) kV

The corresponding value for cable is

$$S > \frac{1400}{U_n^2} [km]$$

### Damping of ferro-resonance

The inductive voltage transformer will be protected from ferro-resonance oscillation by connecting a resistor across the broken delta point in the 3-phase secondary winding.

A typical value is 50-60 ohm, 200 W.

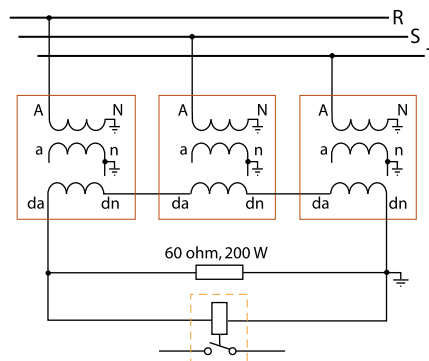

Figure 4.2



### Inductive voltage transformers in high voltage cable net

High voltage cable stores high energy due to the high capacitance in the cable (typical 0.5 µF/km).

If the cable is interrupted, the stored energy in the cable will be discharged through the primary winding of the voltage transformer. The winding will heat up, and in an auto reclose breaking cycle there is a risk of the transformer overheating.

It will take 6-12 hours to cool the transformer, which will delay connection of the cable to the network.

### 4.12 Fuses

It is possible to protect a voltage transformer from secondary short-circuit by incorporating fuses in the secondary circuits. High voltage fuses on the primary side will not protect the transformers, only the network. A short-circuit on the secondary windings produces only a few amperes in the primary winding and is not sufficient to rupture a high voltage fuse.

Typical values for resistance in fuses			
6 A	0.048 Ω	16 A	0.0076 Ω
10 A	0.024 Ω	25 A	0.0042 Ω

### 4.13 Voltage drops in the secondary circuits

The voltage drop in the secondary circuit is of importance. The accuracy of a voltage transformer is guaranteed at the secondary terminals. The voltage drop in the fuses and long connection wires can change the accuracy of the measurement. This is especially important for revenue metering windings of high accuracy (class 0.2 or 0.3). The recommended total voltage drops in the secondary circuits must not be more than 0.05 to 0.1%. Separation of the metering circuits (with low burdens) from protective circuits (with higher burdens) is of the utmost importance.

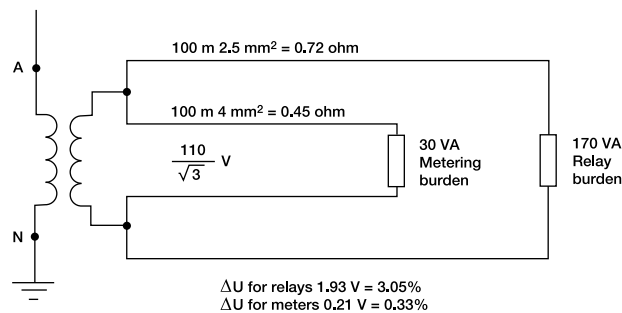

Figure 4.3

The accuracy of a voltage transformer is guaranteed at the secondary terminals

## 4. How to specify voltage transformers

Below is an example of high rated burden (170 VA) resulting in a high voltage drop in the secondary circuit. This illustrates the importance of having a low rated burden for the measuring winding.

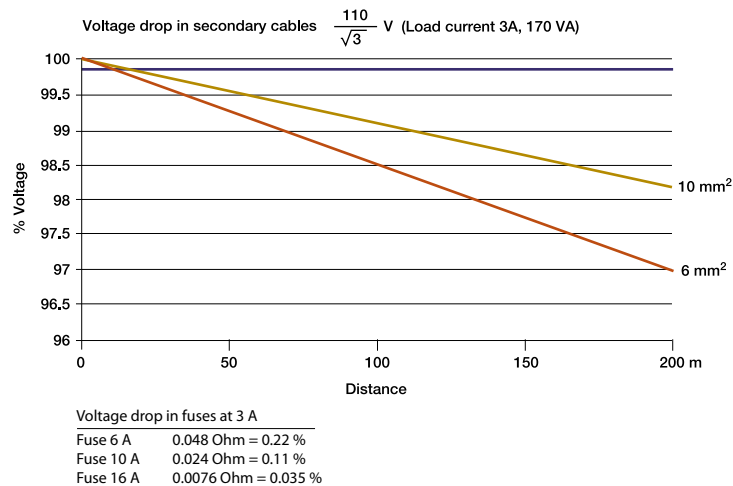

Figure 4.4

Example on voltage drop in secondary cables

### 4.14 Coupling capacitors

In coupling capacitor applications for connecting the power line carrier equipment (PLC) to the network, either a separate capacitor or the capacitor voltage divider of a capacitor voltage transformer can be used.

The minimum capacitance of the coupling capacitors is normally 3 nF but 5 - 6 nF is preferable, especially when using frequencies below 100 kHz. It is sometimes possible to use 2 nF, but this will limit the band pass range. The range and data are dependent of the PLC equipment design.

### 4.15 CVTs as coupling capacitors

It is possible to combine the ABB CVTs as coupling capacitors for line carrier transmission and as a voltage transformer. The "L" terminal in the terminal box gives access to the CVTs capacitor voltage divider. Power line carrier equipment and accessories including drain coil and spark gap protection are available in the terminal box. For external connection of the power line equipment the insulation of the wires must withstand 10 kV RMS test voltage. In modern Line Matching Units the drain coil, sparkgap and grounding switch is integrated in the external unit.

Line traps can be mounted on the top of ABB CVTs and coupling capacitors. Standard fixing pedestals for the most types of line traps are available for mounting on the top of the voltage divider.

However, the weight of the line trap is limited to max. 250 kg for CVTs and coupling capacitors up to 245 kV. Earthquake and extreme wind speed must be taken in consideration (see chapter 7).

The existing PLC equipment will normally be useful after replacement of old CVTs and coupling capacitors. Deviation of the capacitance is not critical. The line tuner unit can be adjusted to/for the new capacitor value. To be sure and not increase the damping of the signal in the lower frequency range the capacitance of the new capacitor must be equal or higher than the old one.

The ABB CVTs type CPA and CPB have the compensating reactor connected on the high voltage side of the primary winding resulting in the possibility of also using higher frequencies (< 500 kHz) for power line carrier transmission.

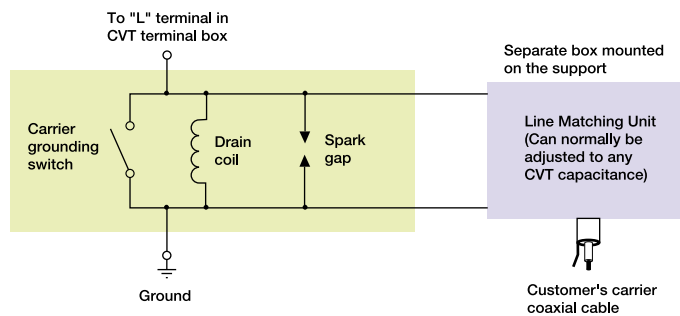

Figure 4.5  
Power line equipment

#### 4.16 Measure harmonics with CVTs

A typical CVT guarantee the accuracy for the fundamental frequency within  $\pm 1-2\%$  deviation. The harmonics will be measured with inferior accuracy.

A CVT can be completed with a so-called patented PQSensor™ (Power Quality Sensor). This sensor increase the accuracy for the harmonics measurement to 0.5% up to the 50<sup>th</sup> harmonics.

##### General description

A power quality sensor is available to very accurately measure power quality parameters such as harmonics and flicker over a wide bandwidth from subsynchronous to high frequencies. The PQSensor™ current probes are installed in capacitor voltage transformers (CVTs) at the ground connection points in the secondary terminal box. The PQSensor™ signal-conditioning unit can be mounted on the CVT support structure making retrofit installation simple.

PQSensor™ gives an additional signal to the CVT standard output. Current probes are two current transformers with a diameter of approximate 5 cm.

## 4. How to specify voltage transformers

The Signal Conditioning Module (SCM) gives an output that is proportional to the CVT input voltage by using the measured currents and capacitor values  $C_1$  and  $C_2$ . The output signal is 20 mA, RMS (FSD) current loop. The CVT burden and EMU circuit do not affect the measurement. Immune to the CVT localized ferro-resonance.

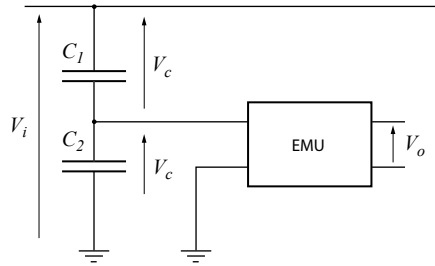

Figure 4.6  
Typical CVT circuit

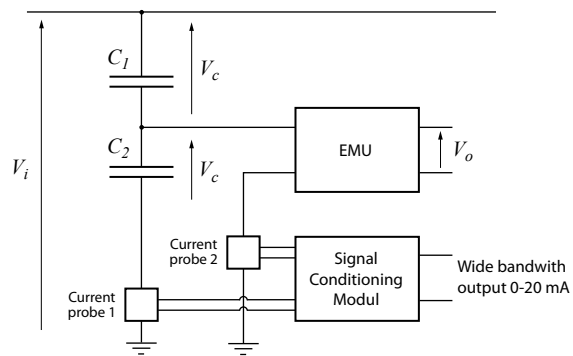

Figure 4.7  
Installation of PQSensors™

## 5. Design of current transformers

### 5.1 General

#### Oil-immersed current transformers

Most of the high voltage current transformers sold and installed today are immersed in oil. There are two main types:

- Tank type with the cores situated in a tank close to the ground. The primary conductor is U-shaped (hair-pin) or coil-shaped (eye-bolt).
- Inverted type (top core) with the cores situated at the top of the transformer. The primary conductor is usually in the shape of a bar. The primary winding can also be coil-shaped.

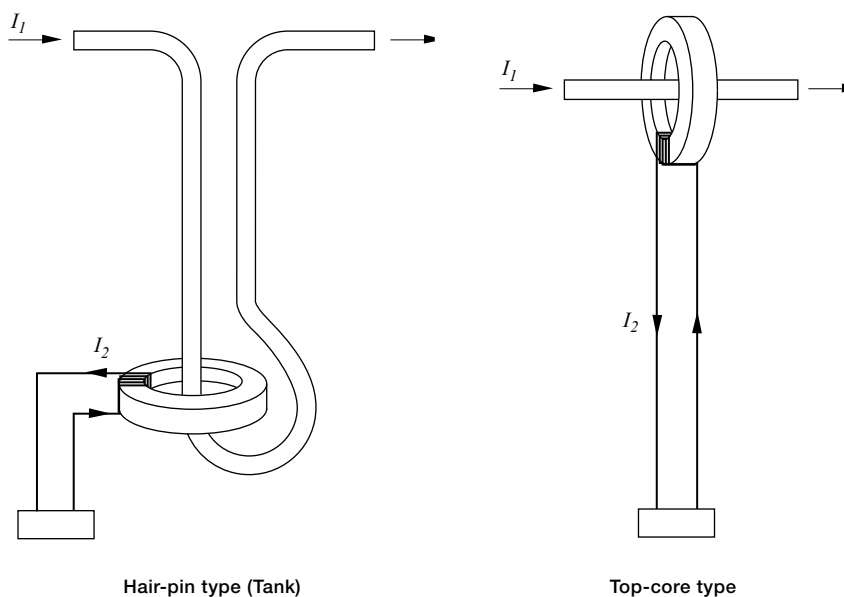

Figure 5.1

#### Epoxy-molded current transformers

Other types of current transformers are epoxy molded. The operating principle is the same as that of oil-immersed current transformers. Epoxy insulated current transformers have the primary winding and the secondary cores embedded in a mixture of epoxy and quartz flour. This gives a well-stabilized design with good fixture of the windings and the cores.

For outdoor erection the epoxy has to withstand climatic stress on the creepage surfaces. A common type of epoxy that can withstand the outdoor climate is cycloalipatic epoxy. However, porcelain and silicone rubber are more resistant to atmospheric corrosion. Epoxy insulated current transformers with creepage surfaces made of porcelain may be a viable option in aggressive environments.

Epoxy-insulated current transformers up to 110 kV level are available on the market, but lower voltage levels are more common.

## 5. Design of current transformers

### **SF<sub>6</sub> gas insulated current transformers**

For the SF<sub>6</sub> gas insulated current transformers the oil and paper insulation have been replaced by Sulphurhexafluoride (SF<sub>6</sub>) gas. The gas is not flammable and has good dielectric and thermal capabilities. The design is typical top core type.

The gas is solely for insulating purposes, although it will not improve the insulation of the current transformer. The high overpressure (4-5 bar) of the gas requires high performance of the insulators, vessel and gaskets.

### **Silicon rubber insulators**

Silicon rubber insulators are an alternative to ceramic insulators for instrument transformers.

Because of the unique non-wetting properties, silicone rubber is the fastest growing, and for high voltage even the dominating, polymeric insulation material.

Compared with ceramic insulation, silicon rubber has the additional advantages of light weight and being non-brittle. Depending on the type of equipment, additional technical advantages and safety improvements are obtained.

Silicon rubber insulators manufactured by ABB have been continuously tested in both normal and severely polluted conditions with good results for many years.

Today an increasing number of different high voltage apparatus with silicone rubber insulation are being installed, e.g. surge arresters, bushings, circuit breakers and instrument transformers.

### **5.2 Hair-pin type (Tank type)**

#### **Advantages**

- Low centre of gravity.
- High earthquake resistance.
- Using heavy cores without stressing the porcelain insulator.
- Easy to adapt the core volume to different requirements.
- High quality with the use of machines when insulating the primary conductor.
- The tank is part of the support.
- Oil circulation in the primary conductor (tube) ensures an even temperature and no hot spots.

#### **Additional advantages with ABB's unique quartz filling**

- Low oil volume
- Having the primary conductor and cores embedded in quartz filling means that the current transformer can withstand strong vibrations, which is important during transport and earthquakes.
- Quartz filling affords the opportunity to have expansion systems with no moving parts such as bellows or membranes.

#### **Disadvantage**

- Long primary conductor means higher thermal losses. Limitation of the short-circuit currents. (Max. 63 kA/1 s).

### **5.3 Cascade/Eye-bolt type**

#### **Advantage**

- Hybrid between hair-pin and top-core design.

#### **Disadvantage**

- Long primary conductor means thermal losses and the current transformer will not be very competitive compared to other transformers at currents above 2000 A.
- Difficult in cooling the primary conductor.
- Limitation of the short-circuit currents.
- Difficult to have large core volumes. While being insulated the core must be assembled on the primary conductor.

### **5.4 Top core type**

#### **Advantages**

- Short primary conductor with low thermal losses
- High rated current and short-time current.

#### **Disadvantage**

- High centre of gravity
- Large core volume stresses the porcelain insulator
- Limited core volume
- Difficult to cool the secondary windings, which are embedded in paper insulation.
- Unsuitable in earthquake areas when using big cores (TPX, TPY).

## 5. Design of current transformers

### 5.5 Combined current-voltage type

#### Advantages

- Measure current and voltage in the same unit.
- Save space and support.

#### Disadvantages

- Limited core volume for current measuring.
- Less flexible

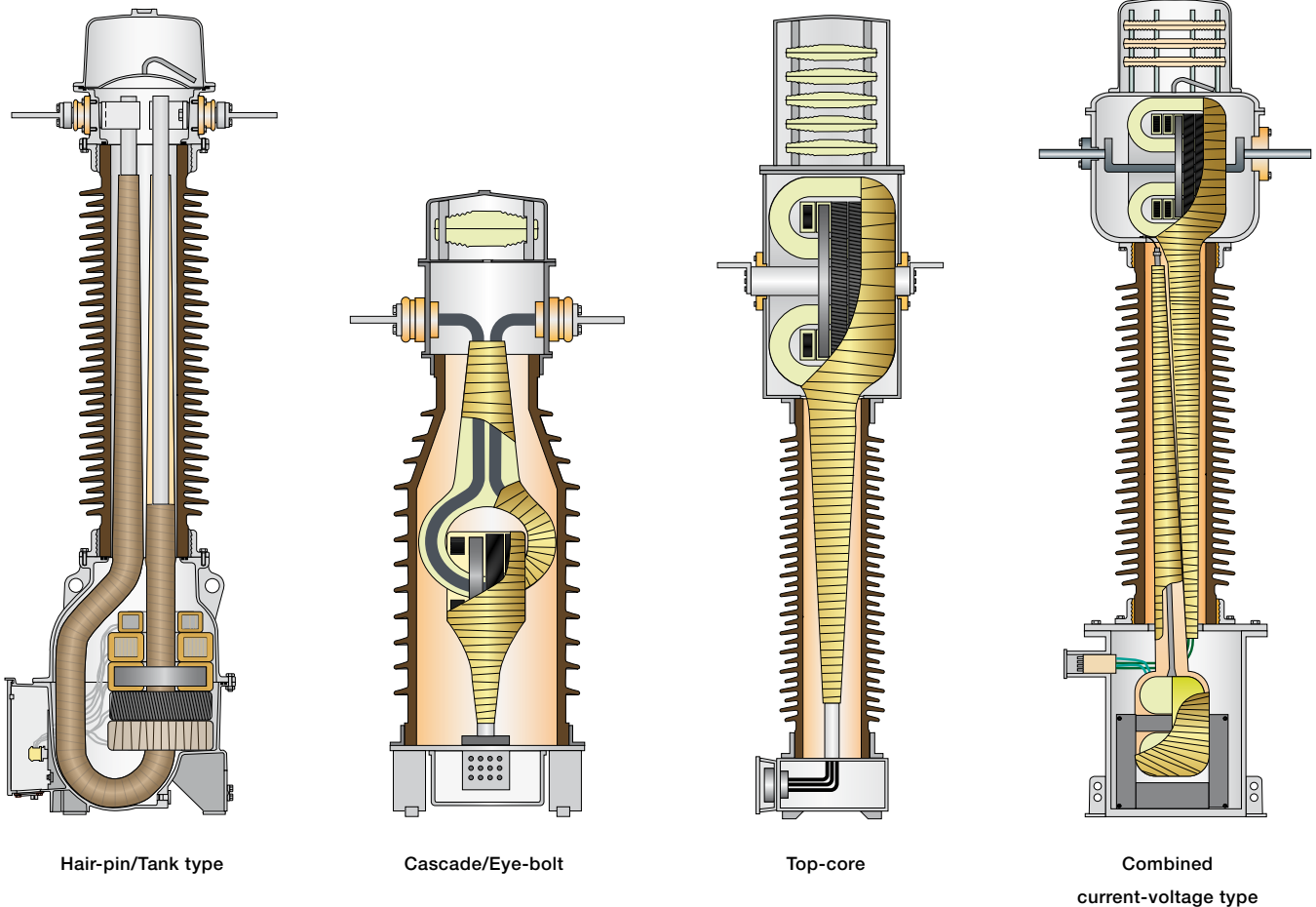

Figure 5.2  
Typical designs of CTs



## 5.6 Mechanical stress on current transformers

Current transformers in operation are mechanically stressed in different ways:

### 5.6.1 Forces in the primary terminals

Connected bars and wires develop the forces in primary terminals. There is a static stress from the weight of the connected conductor and a dynamic stress from wind and vibrations in circuit breaker operation. Electrodynamic forces will also occur under short-circuit conditions. Test forces in the primary terminals according to IEC at table below.

Highest voltage for equipment $U_m$	Static withstand test load $F_R$		
	Voltage terminals	Instrument transformers with:	
		Current terminals	
kV		Load: class I	Load: class II
72.5 - 100	500	1250	2500
123 - 170	1000	2000	3000
245 - 362	1250	2500	4000
$\geq 420$	1500	4000	5000

NOTE 1: The sum of the loads acting in routinely operating conditions should not exceed 50 % of the specified withstand test load.

NOTE 2: In some applications instrument transformers with through current terminals should withstand rarely occurring extreme dynamic loads (e.g. short circuits) not exceeding 1.4 times the static test load.

NOTE 3: For some applications it may be necessary to establish the resistance to rotation of the primary terminals. The moemnt to be applied during the test has to be agreed between manufacturer and purchaser.

NOTE 4: In the case of transformers integrated within other equipment (e.g. switchgear assemblies) the static with stand test loads of the respective equipment should not be diminished by the integration process.

### 5.6.2 Wind load

A current transformer must also withstand the stress of wind. The wind speed depends on the climatic conditions. The maximum wind speed which might occur is about 50 m/s (180 km/h). A normal figure is 35 m/s. ABB's current transformers are designed for 50 m/s with a simultaneous load of 2000 N (force) applied to the primary terminals. In this instance, the safety factor will be 2.

## 5. Design of current transformers

### 5.6.3 Seismic withstand

In earthquake regions the current transformer must withstand the seismic stress caused by an earthquake. The figure of acceleration is determined by the region where the current transformer is erected. The value of horizontal acceleration is normally 0.1 to 0.5 g and in exceptional cases up to 1.0 g. The stress in the current transformer is dependent on the total configuration of the design of the support, response spectra and damping. To exactly verify the stress in the current transformer a calculation must be carried out from case to case. Generally ABB's current transformers can withstand 0.5 g seismic stress according to IEC spectrum with a safety factor of 1.5 for current transformers up to a 300 kV system voltage. For higher voltage levels and earthquake requirements the current transformers will be designed according to the requirements.

## 6. Design of inductive voltage transformers

ABB's voltage transformer has a unique quartz filling that improves mechanical stability and reduces oil volumes. Core and windings are situated in the bottom tank and the porcelain insulator is mounted on the top of the tank. For higher voltage levels (> 245 kV) a cascade type is usual, but a modern capacitor voltage transformer will be more economical.

The cascade type consists of two inductive voltage transformers with different potential integrated in the same enclosure.

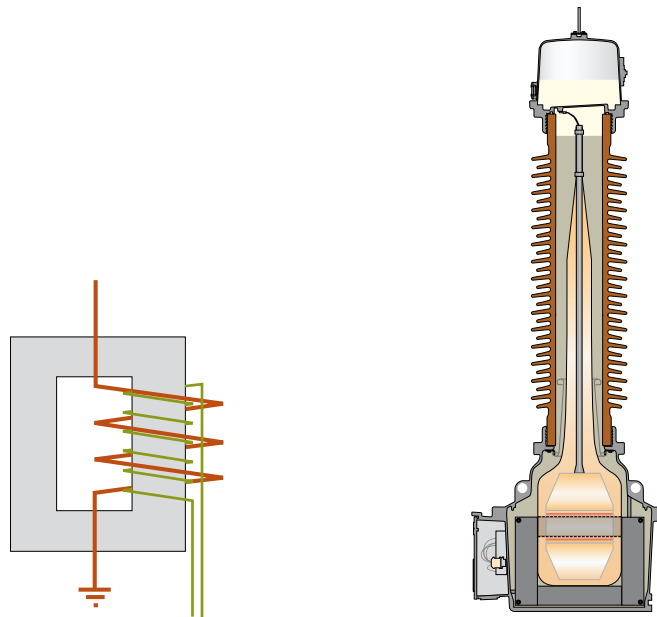

Figure 6.1  
Inductive voltage transformer

### 6.1 Mechanical stress on inductive voltage transformers

As in the case of current transformers, a voltage transformer is subject to mechanical stresses due to forces in the primary terminal, wind forces and earthquakes. The load on the primary terminal is normally lower than on a current transformer. The connection lead weighs less because of the very low current in the voltage transformer which can be transferred by a thinner wire. Test forces in primary terminals according to IEC. See table at chapter 5.6.1.

## 7. Design of capacitor voltage transformers

A capacitor voltage transformer consists of a Capacitor Voltage Divider (CVD) and an inductive Intermediate Voltage Transformer (IVT). The IVT voltage level of ABB's capacitor voltage transformers is about  $22/\sqrt{3}$  kV, and the rated voltage of the complete capacitor voltage transformer determines the ratio at the capacitor voltage divider.

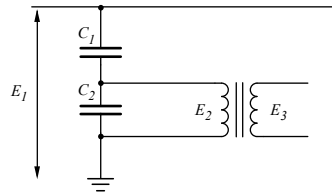

Figure 7.0

It is more convenient to make an Inductive voltage transformer for lower voltage levels and let the CVD take care of the high voltage.

The ratio of the capacitive divider is

$$K_1 = \frac{C_1 + C_2}{C_1} = \frac{E_1}{E_2}$$

The ratio of the intermediate voltage transformer is

$$K_2 = \frac{E_2}{E_3}$$

The total ratio factor is therefore

$$K = K_1 \times K_2$$

$K_1$  is normally chosen to give  $E_2 = 22/\sqrt{3}$  kV. Thus for different primary voltages, only  $C_1$  differs and a standard intermediate transformer can be used for all primary voltages. The intermediate voltage transformer (IVT) also contains reactors for compensation of the capacitive voltage regulation.

The capacitor voltage transformer has a double function, one for metering/protection and one for power line communications (PLC).

CVT quality depends on formula:

$$Q = U_m^2 \times C_e > 10$$

$$C_e = C_1 + C_2 \text{ } [\mu\text{F}]$$

$$U_m = U_n / \sqrt{3} \times (\text{cap} - \text{ratio}) \text{ } [\text{kV}]$$

A high performance CVT the Q must be >10.

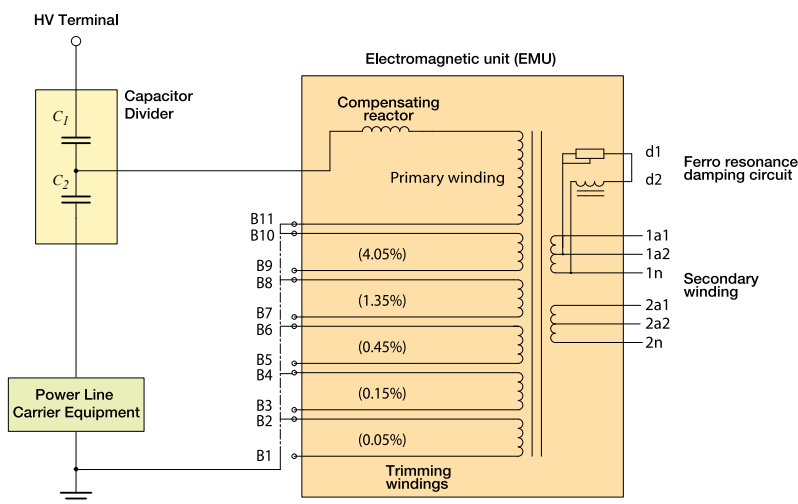

Figure 7.1  
Principle diagram for a capacitor voltage transformer

## 7.1 External disturbances on capacitor voltage transformers

### Pollution

External creepage currents due to pollution on insulators can influence the accuracy of a capacitor voltage transformer. When a porcelain insulator is divided into several parts, there can be different creepage currents in each part of the capacitor voltage divider. This has an effect on voltage dividing in the capacitor and results in a ratio error. The proportion of errors is difficult to estimate, as it is not easy to measure the different creepage currents. High capacitance in the voltage divider makes it less sensitive to pollution.

## 7. Design of capacitor voltage transformers

### Stray capacitance

The effect of stray capacitance from equipment erected nearby on accuracy is negligible. If two 420 kV capacitor voltage transformers are erected at a distance of 1.25 m from each other, the ratio error of ABB's high capacitance CVT due to the other capacitor voltage transformer will be 0.01%. Normally the phase distance is longer than 1.25 m. Therefore, the high capacitance of the voltage divider has a positive effect on the accuracy.

### 7.2 Mechanical stress on capacitor voltage transformers

As with current transformers the capacitor voltage transformers are also exposed to similar mechanical stresses from forces in the primary terminals, wind and earthquakes. The load on the primary terminals is normally lower than that on a current transformer. The connection lead weighs less because of the very low current in the voltage transformer, which can be transferred by a thinner wire. A typical requirement on static and dynamic load is 1000 N with a safety factor of 2. The limitation of the stress is the bending moment in the porcelain insulator. A typical value for a standard insulator is 25 kNm ( $T_{max}$ ), but it is possible to obtain a higher value.

$$F_{max} = \frac{T_{max}}{S \times H}$$

where

$F_{max}$	Maximum horizontal force on the primary terminal (kN)
$S$	Safety factor, usually 2
$H$	Height of the capacitor (CVD) (m)
$T_{max}$	Maximum bending strength of the porcelain insulator (kNm)

$F_{max}$  must be reduced according to the wind load.

The following part describes the calculation of wind load on a capacitor voltage transformer. The additional wind load with line traps placed on top of the capacitor voltage transformer is also of importance.

Wind pressure ( $W$ ) will be specified for cylindrical surfaces:

$$W = 0.6 \times V^2 \text{ [N/m}^2\text{]}$$

where

$V$	Wind speed (m/s) (IEC 34 m/s)
-----	-------------------------------

We assume that the capacitor voltage transformer has a cylindrical shape. The force ( $F$ ) will take up half the height of the CVD:

$$F = W \times H \times D^1 \text{ [N]}$$

where

$D^1$  Medium diameter of the porcelain

The moment ( $M$ ) will be:

$$M = \frac{1}{2} \times H \times F \text{ [Nm]}$$

If the capacitor voltage transformer is provided with line traps; this must also be taken into account:

$$F_s = W \times H_s \times D_s \text{ [N]}$$

$$M_s = \left( H + \frac{1}{2} \times H_s \right) \times F_s \text{ [Nm]}$$

where

$H_s$  Line trap height (m)

$D_s$  Line trap diameter (m)

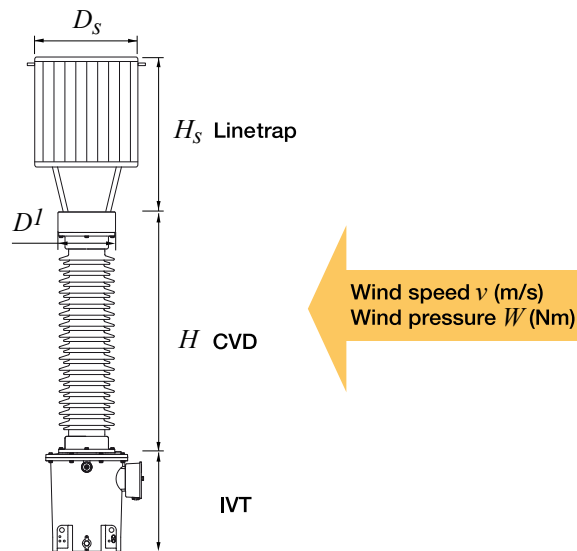

Figure 7.2

## 7. Design of capacitor voltage transformers

### 7.3 Seismic properties of ABB's capacitor voltage transformers

The requirements on the seismic withstand capability of capacitor voltage transformers usually depend on the local seismic conditions. This means that a particular calculation has to be performed in each individual case. Some general rules and also a few examples of requirements ABB has been able to fulfill are given below.

Due to its slender shape, a capacitor voltage transformer is more sensitive to horizontal movements than vertical ones. Generally, if a capacitor voltage transformer can withstand the horizontal requirements, the vertical requirements are usually satisfied automatically.

The difficulties in meeting earthquake requirements increase rapidly with the height of the CVD, i.e. the system voltage.

#### **Response spectra**

If the requirements, formulated as an acceleration spectrum of a probable earthquake, have to be met at a certain safety factor, a CPA or CPB will always withstand 0.3 g horizontal ground acceleration according to IEC spectra with a safety factor of 2.0 up to 550 kV highest system voltage.

For particularly heavy applications a capacitor voltage transformer with stronger porcelain can be designed to withstand 0.5 g horizontal and 0.3 g vertical acceleration with a safety factor of 2.0.

#### **Resonance frequency tests**

If the requirement says that the CVT shall withstand mechanical testing at its resonance frequency, the damping will be the most important factor in the calculation.

Earthquake calculations will normally be performed from case to case depending on the requirements. As these calculations could be complicated to perform, modern cost-saving computer programs have been developed. With help of these programs high precision calculations can be made. However, some tests must still be performed to verify these calculations.



## 8. Instrument transformers in the system

### 8.1 Terminal designations for current transformers

According to IEC publication 60044-1, the terminals should be designated as shown in the following diagrams. All terminals that are marked P1, S1 and C1 are to have the same polarity.

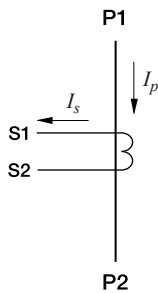

Figure 8.1

Transformer with one secondary winding

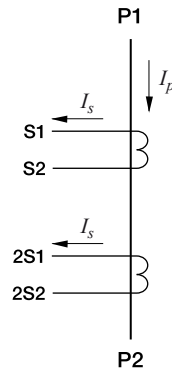

Figure 8.2

Transformer with two secondary windings

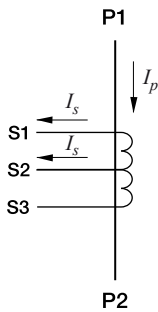

Figure 8.3

Transformer with one secondary winding which has an extra tapping

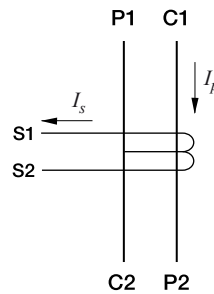

Figure 8.4

Transformer with two primary windings and one secondary winding

# 8. Instrument transformers in the system

## 8.2 Secondary grounding of current transformers

To prevent the secondary circuits from attaining dangerously high potential to ground, these circuits have to be grounded. Connect either the S1 terminal or the S2 terminal to ground.

For protective relays, ground the terminal that is nearest to the protected objects. For meters and instruments, ground the terminal that is nearest to the consumer.

When metering instruments and protective relays are on the same winding, the protective relay determines the point to be grounded.

If there are unused taps on the secondary winding, they must be left open.

If there is a galvanic connection between more than one current transformer, these shall be grounded at one point only (e.g. differential protection).

If the cores are not used in a current transformer they must be short-circuited between the highest ratio taps and shall be grounded.



### WARNING!

It is dangerous to open the secondary circuit when the CT is in operation. High voltage will be induced.

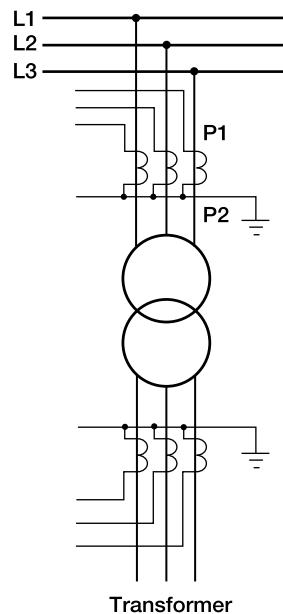

Figure 8.5  
Transformer

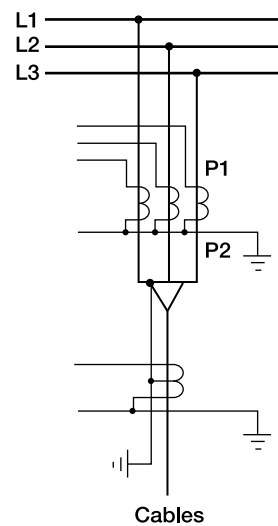

Figure 8.6  
Cables

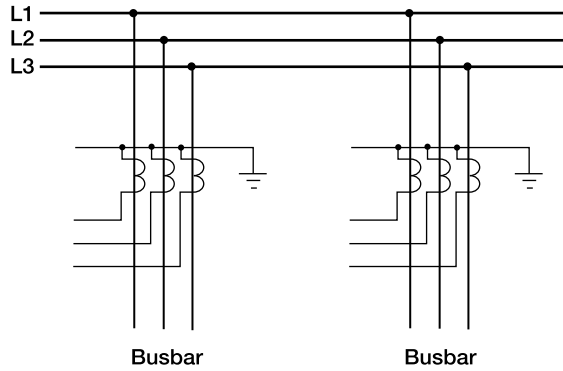

Figure 8.7  
Busbar

### 8.3 Secondary grounding of voltage transformers

To prevent secondary circuits from reaching dangerous potential, the circuits shall be grounded. Grounding shall be made at only one point on a voltage transformer secondary circuit or galvanically interconnected circuits.

A voltage transformer, which on the primary is connected phase to ground, shall have the secondary grounding at terminal n.

A voltage transformer, with the primary winding connected between two phases, shall have the secondary circuit, which has a voltage lagging the other terminal by 120 degrees, grounded.

Windings not in use shall be grounded.

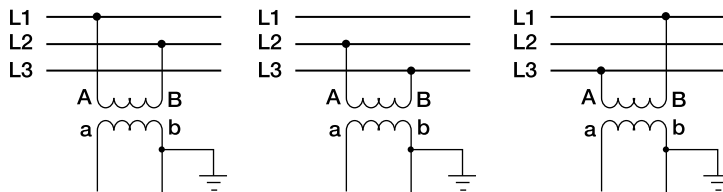

Figure 8.8  
Voltage transformers connected between phases

## 8. Instrument transformers in the system

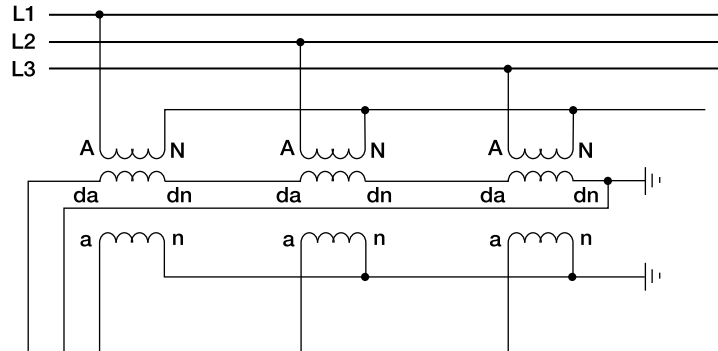

Figure 8.9

A set of voltage transformers with one Y-connected and one broken delta secondary circuit

### 8.4 Connection to obtain the residual voltage

The residual voltage (neutral displacement voltage, polarizing voltage) for earth-fault relays can be obtained from a voltage transformer between neutral and ground, for instance at a power transformer neutral. It can also be obtained from a three-phase set of voltage transformers, which have their primary winding connected phase to ground and one of the secondary windings connected in a broken delta.

Figure 8.10 illustrates the measuring principle for the broken delta connection during an earth-fault in a high-impedance grounded (or ungrounded) and an effectively grounded power system respectively.

From the figure, it can be seen that a solid close-up earth-fault produces an output voltage of

$$U_{rsd} = 3 \times U_{2n}$$

in a high-impedance earthed system and

$$U_{rsd} = U_{2n}$$

in an effectively grounded system. Therefore a voltage transformer secondary voltage of

$$U_{2n} = \frac{110}{3} V$$

is often used in high-impedance grounded systems and  $U_{2n} = 110\text{ V}$  in effectively grounded systems. A residual voltage of 110 V is obtained in both cases. Voltage transformers with two secondary windings, one for connection in Y and the other in broken delta can then have the ratio

$$\frac{U_n}{\sqrt{3}} / \frac{110}{\sqrt{3}} / \frac{110}{3}$$

$$\frac{U_n}{\sqrt{3}} / \frac{110}{\sqrt{3}} / 110$$

for high-impedance and effectively grounded systems respectively. Nominal voltages other than 110 V, e.g. 100 V or 115 V, are also used depending on national standards and practice.

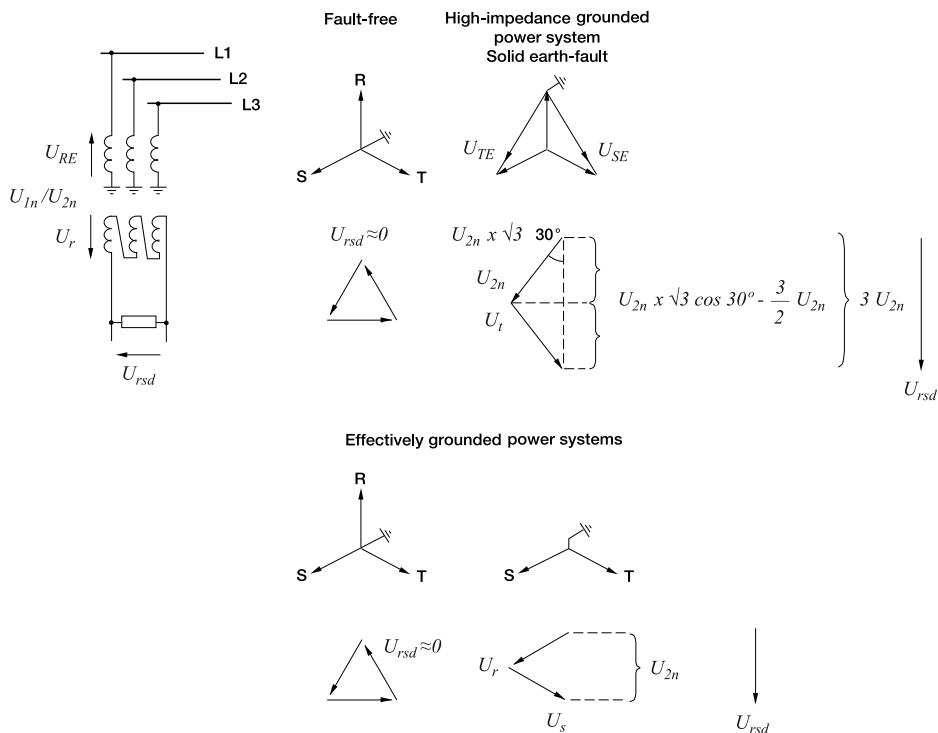

Figure 8.10

Residual voltage (neutral displacement voltage) from a broken delta circuit

# 8. Instrument transformers in the system

## 8.5 Fusing of voltage transformer secondary circuits

Fuses should be provided at the first box where the three phases are brought together. The circuit from the terminal box to the first box is constructed to minimize the risk of faults in the circuit. It is preferable not to use fuses in the voltage transformer terminal box, as this will make the supervision of the voltage transformers more difficult. The fuses in the three-phase box enable a differentiated fusing of the circuits to different loads like protection and metering circuits.

The fuses must be selected to give a fast and reliable fault clearance, even for a fault at the end of the cabling. Earth faults and two-phase faults should be checked.

## 8.6 Location of current and voltage transformers in substations

Instrument transformers are used to supply measured quantities of current and voltage in an appropriate form to controlling and protective apparatus, such as energy meters, indicating instruments, protective relays, fault locators, fault recorders and synchronizers.

Instrument transformers are thus installed when it is necessary to obtain measuring quantities for the above-mentioned purposes.

Typical points of installation are switchbays for lines, feeders, transformers, bus couplers, etc., at transformer neutral connections and at the busbars.

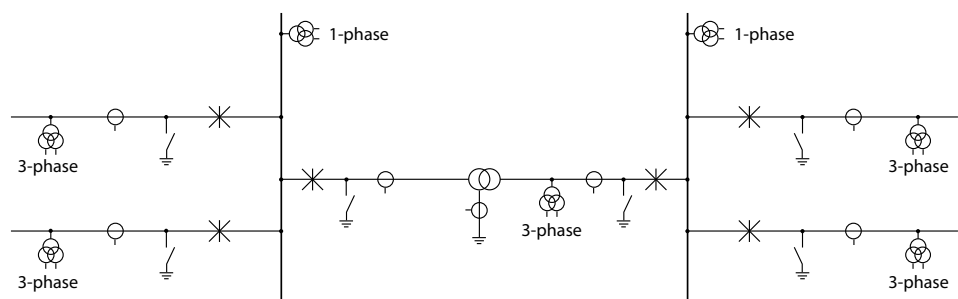
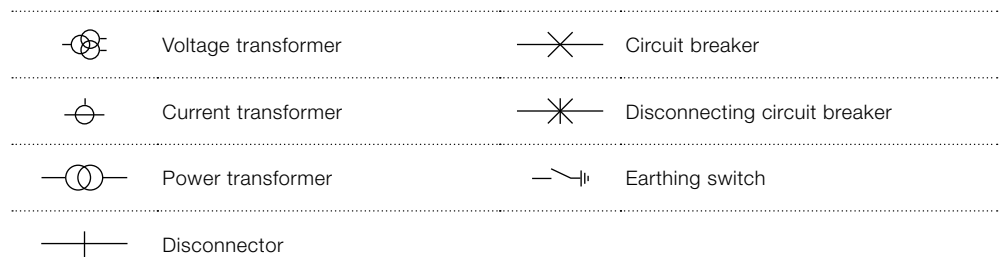

Figure 8.11  
Current and voltage transformers in a substation

### Location of instrument transformers in different substation arrangements

Below are some examples of suitable locations for current and voltage transformers in a few different switchgear arrangements.

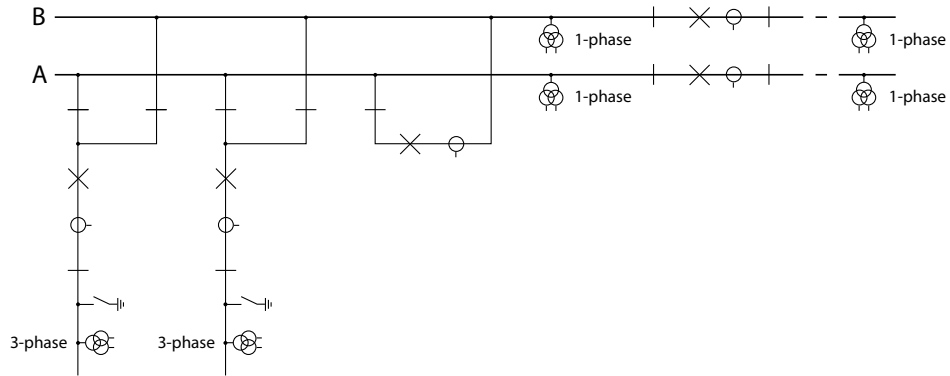

Figure 8.12  
Double busbar station

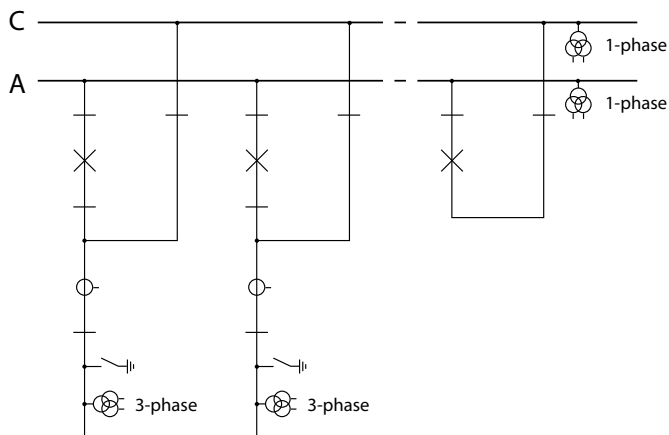

Figure 8.13  
Station with transfer busbar

## 8. Instrument transformers in the system

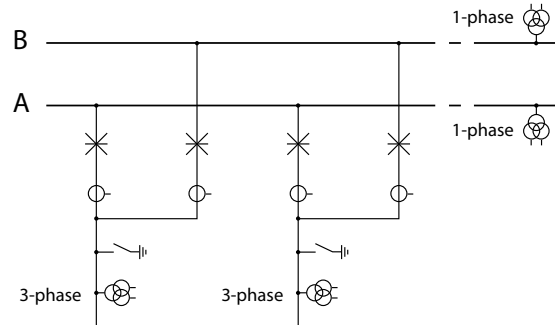

Figure 8.14  
Double breaker and double busbar station

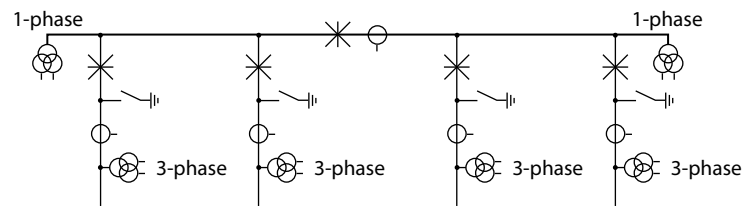

Figure 8.15  
Sectionalized single busbar station

### 8.6.1 Location of current transformers

#### Current transformers in line bays

The current transformers are placed near the circuit breakers and on the line side. The detection zones of line relays and busbar relays start at the current transformers and the tripping point is the circuit breaker. It is advantageous if these two points are close to each other. In the improbable case of a fault between the current transformer and the circuit breaker, the busbar protection will detect and clear the fault.

#### Bus coupler and bus sectionalizer bays

A set of current transformers is necessary to enable different busbar protection zones to be formed. The protection can be arranged to give complete fault clearing with a short time-delay for faults between circuit breaker and current transformer. Sometimes current transformers on both sides of circuit breakers are used but are usually not necessary. It will depend on the arrangement of protective relays.



### Transfer busbar station

It is advantageous to locate the current transformers on the line side of the disconnectors for circuit breakers and the transfer bus. In this way the protective relay connected to the current transformer will remain connected to the line when it is switched over to transfer busbar and standby circuit breaker.

### Double breaker station

It is usual to locate the current transformers on the line side of the circuit breakers. The two current transformers shall be identical. To determine the line current, the secondary currents of the two current transformers are added together.

### One and a half breaker station

As with the double breaker station, current transformers are located at the circuit breakers. In addition, transformer bushing current transformers are used. At the central circuit breaker (tie circuit breaker) two current transformer sets are shown. It is also possible to use a single set of current transformers, but sometimes it can be difficult to accommodate all cores in one current transformer tank.

### 8.6.2. Transformer and reactor bushing current transformers

Bushing current transformers can be a good and economical complement to separate current transformers if properly adapted to the requirements for protection and metering. It is important to specify the current transformers correctly when purchasing the transformer, as it is difficult to exchange them once they are installed in the power transformer. A current transformer in a power transformer neutral can be a bushing current transformer or a separate 36 kV or 24 kV unit.

### 8.6.3. Physical order of cores in a current transformer

It is usual to show the use of current transformer cores in a diagram in such way that protective relays overlap inside the current transformer. It is, of course, correct to arrange the current transformer cores in that order, but if the cores of one CT should be reversed there is no practical effect. The current through the current transformer cores is the same. Figure 8.15 is a cross section of a current transformer. A fault from the primary conductor to earth between the cores is extremely unlikely. If this should happen, it is hard to predict the operation of the relays anyhow, as the windings of the adjacent cores might be destroyed.

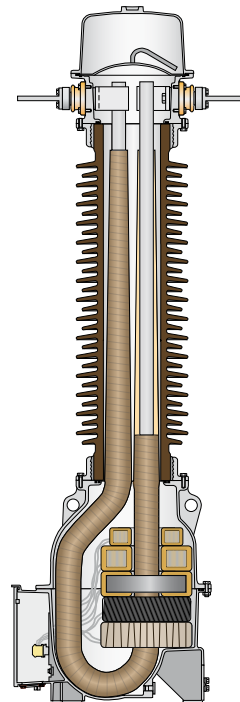

**Figure 8.15**  
Cross section of a current transformer

## 8. Instrument transformers in the system

### 8.6.4 Location of voltage transformers

In line bays a three-phase set of voltage transformers or capacitor voltage transformers is used for metering, protection and synchronization. Located at the entry they can also enable indication of voltage on a line energized from the opposite end. Capacitor voltage transformers can also be used as coupling capacitors for power line carrier (PLC). They are then to be located at the line side of the line traps and line earthing switches, as shown in chapter 1.3.

Single-phase voltage transformers on the busbars and at transformers provide reference voltage for synchronization. If these voltage transformers are selected a voltage selection scheme must be used. It will be more or less complex depending on the switchgear configuration. A similar case is the single-phase voltage transformer on the station side of the line disconnector in a 1 ½ circuit breaker station.

## 9. Protective relays

The performance of a protection function will depend on the quality of the measured current signal. Saturation of the current transformer (CT) will cause distortion of the current signal and can result in a failure to operate or cause unwanted operations of some functions. Consequently CT saturation can have an influence on both the dependability and the security of the protection. This protection IED has been designed to permit heavy CT saturation with maintained correct operation.

### 9.1 Current transformer classification

To guarantee correct operation, the current transformers (CTs) must be able to correctly reproduce the current for a minimum time before the CT will begin to saturate. To fulfil the requirement on a specified time to saturation the CTs must fulfil the requirements of a minimum secondary e.m.f. that is specified below.

There are several different ways to specify CTs. Conventional magnetic core CTs are usually specified and manufactured according to some international or national standards, which specify different protection classes as well. There are many different standards and a lot of classes but fundamentally there are three different types of CTs:

#### – High remanence type CT

The high remanence type has no limit for the remanent flux. This CT has a magnetic core without any air gap and a remanent flux might remain for almost infinite time. In this type of transformers the remanence can be up to around 80 % of the saturation flux. Typical examples of high remanence type CT are class P, PX, TPS, TPX according to IEC and nongapped class C, T and X according to ANSI/IEEE.

#### – Low remanence type CT

The low remanence type has a specified limit for the remanent flux. This CT is made with a small air gap to reduce the remanence to a level that does not exceed 10 % of the saturation flux. The small air gap has only very limited influence on the other properties of the CT. Class PR, TPY according to IEC are low remanence type CTs.

#### – Non remanence type CT

The non remanence type CT has practically negligible level of remanent flux. This type of CT has relatively big air gaps in order to reduce the remanence to practically zero level. In the same time, these air gaps reduce the influence of the DC-component from the primary fault current. The air gaps will also decrease the measuring accuracy in the non-saturated region of operation. Class TPZ according to IEC is a non remanence type CT.

Different standards and classes specify the saturation e.m.f. in different ways but it is possible to approximately compare values from different classes. The rated equivalent limiting secondary e.m.f.  $E_{dl}$  according to the IEC 60044 6 standard is used to specify the CT requirements for ABB relays. The requirements are also specified according to other standards.

# 9. Protective relays

## 9.2 Conditions

The requirements are a result of investigations performed in our network simulator. The current transformer models are representative for current transformers of high remanence and low remanence type. The results may not always be valid for non remanence type CTs (TPZ).

The performances of the protection functions have been checked in the range from symmetrical to fully asymmetrical fault currents. Primary time constants of at least 120 ms have been considered at the tests. The current requirements below are thus applicable both for symmetrical and asymmetrical fault currents.

Depending on the protection function phase-to-earth, phase-to-phase and three-phase faults have been tested for different relevant fault positions e.g. close in forward and reverse faults, zone 1 reach faults, internal and external faults. The dependability and security of the protection was verified by checking e.g. time delays, unwanted operations, directionality, overreach and stability.

The remanence in the current transformer core can cause unwanted operations or minor additional time delays for some protection functions. As unwanted operations are not acceptable at all maximum remanence has been considered for fault cases critical for the security, e.g. faults in reverse direction and external faults. Because of the almost negligible risk of additional time delays and the non-existent risk of failure to operate the remanence have not been considered for the dependability cases. The requirements below are therefore fully valid for all normal applications.

It is difficult to give general recommendations for additional margins for remanence to avoid the minor risk of an additional time delay. They depend on the performance and economy requirements. When current transformers of low remanence type (e.g. TPY, PR) are used, normally no additional margin is needed. For current transformers of high remanence type (e.g. P, PX, TPS, TPX) the small probability of fully asymmetrical faults, together with high remanence in the same direction as the flux generated by the fault, has to be kept in mind at the decision of an additional margin. Fully asymmetrical fault current will be achieved when the fault occurs at approximately zero voltage ( $0^\circ$ ). Investigations have shown that 95% of the faults in the network will occur when the voltage is between  $40^\circ$  and  $90^\circ$ . In addition fully asymmetrical fault current will not exist in all phases at the same time.

## 9.3 Fault current

The current transformer requirements are based on the maximum fault current for faults in different positions. Maximum fault current will occur for three-phase faults or single-phase-to-earth faults. The current for a single phase-to-earth fault will exceed the current for a three-phase fault when the zero sequence impedance in the total fault loop is less than the positive sequence impedance.

When calculating the current transformer requirements, maximum fault current for the relevant fault position should be used and therefore both fault types have to be considered.

#### 9.4 Secondary wire resistance and additional load

The voltage at the current transformer secondary terminals directly affects the current transformer saturation. This voltage is developed in a loop containing the secondary wires and the burden of all relays in the circuit. For earth faults the loop includes both the phase and neutral wire, normally twice the resistance of the single secondary wire. For three-phase faults the neutral current is zero and it is just necessary to consider the resistance up to the point where the phase wires are connected to the common neutral wire. The most common practice is to use four wires secondary cables so it normally is sufficient to consider just a single secondary wire for the three-phase case.

The conclusion is that the loop resistance, twice the resistance of the single secondary wire, must be used in the calculation for phase-to-earth faults and the phase resistance, the resistance of a single secondary wire, may normally be used in the calculation for three-phase faults.

As the burden can be considerable different for three-phase faults and phase-to-earth faults it is important to consider both cases. Even in a case where the phase-to-earth fault current is smaller than the three-phase fault current the phase-to-earth fault can be dimensioning for the CT depending on the higher burden.

In isolated or high impedance earthed systems the phase-to-earth fault is not the dimensioning case and therefore the resistance of the single secondary wire always can be used in the calculation.

#### 9.5 General current transformer requirements

The current transformer ratio is mainly selected based on power system data like e.g. maximum load. However, it should be verified that the current to the protection is higher than the minimum operating value for all faults that are to be detected with the selected CT ratio. The minimum operating current is different for different functions and normally settable so each function should be checked.

The current error of the current transformer can limit the possibility to use a very sensitive setting of a sensitive residual overcurrent protection. If a very sensitive setting of this function will be used it is recommended that the current transformer should have an accuracy class which have a current error at rated primary current that is less than  $\pm 1\%$  (e.g. 5P). If current transformers with less accuracy are used it is advisable to check the actual unwanted residual current during the commissioning.

#### 9.6 Rated equivalent secondary e.m.f. requirements

With regard to saturation of the current transformer all current transformers of high remanence and low remanence type that fulfill the requirements on the rated equivalent secondary e.m.f.  $E_{dl}$  below can be used. The characteristic of the non remanence type CT (TPZ) is not well defined as far as the phase angle error is concerned, and we therefore recommend contacting ABB to confirm that the type in question can be used.

## 9. Protective relays

The CT requirements for the different functions below are specified as a rated equivalent limiting secondary e.m.f.  $E_{al}$  according to the IEC 60044-6 standard. Requirements for CTs specified in different ways are given at the end of this section.

### 9.6.1 Line distance protection REL670 and REL650

The CTs must have a rated equivalent secondary e.m.f.  $E_{al}$  that is larger than or equal to the maximum of the required secondary e.m.f.  $E_{alreq}$  below:

$$E_{al} \geq E_{alreq} = \frac{I_{kmax} \cdot I_{sn}}{I_{pn}} \cdot a \cdot \left( R_{CT} + R_L + \frac{S_R}{I_r^2} \right)$$

Equation 9.1

$$E_{al} \geq E_{alreq} = \frac{I_{kzone1} \cdot I_{sn}}{I_{pn}} \cdot k \cdot \left( R_{CT} + R_L + \frac{S_R}{I_r^2} \right)$$

Equation 9.2

where

$I_{kmax}$	Maximum primary fundamental frequency current for close-in forward and reverse faults (A).
$I_{kzone1}$	Maximum primary fundamental frequency current for faults at the end of zone 1 reach (A).
$I_{pn}$	The rated primary CT current (A).
$I_{sn}$	The rated secondary CT current (A).
$I_r$	The rated current of the protection IED (A).
$R_{CT}$	The secondary resistance of the CT ( $\Omega$ ).
$R_L$	The resistance of the secondary wire and additional load ( $\Omega$ ). In solidly earthed systems the loop resistance containing the phase and neutral wires should be used for phase-to-earth faults and the resistance of the phase wire should be used for three-phase faults. In isolated or high impedance earthed systems the resistance of the single secondary wire always can be used.
$S_R$	The burden of one current input channel (VA). REL670: $S_R = 0.020$ VA/channel for $I_r = 1$ A and $S_R = 0.150$ VA/channel for $I_r = 5$ A REL650: $S_R = 0.010$ VA/channel for $I_r = 1$ A and $S_R = 0.250$ VA/channel for $I_r = 5$ A
$a$	This factor is a function of the primary time constant for the dc component in the fault current. $a = 2$ for the primary time constant $T_p \leq 50$ ms $a = 3$ for the primary time constant $T_p > 50$ ms
$k$	A factor of the primary time constant for the dc component in the fault current for a three-phase fault at the set reach of zone 1. $k = 4$ for the primary time constant $T_p \leq 30$ ms $k = 6$ for the primary time constant $T_p > 30$ ms

## 9.6.2 Line differential protection RED670

### 9.6.2.1 Line differential function

The CTs must have a rated equivalent secondary e.m.f.  $E_{al}$  that is larger than or equal to the maximum of the required secondary e.m.f.  $E_{alreq}$  below:

$$E_{al} \geq E_{alreq} = I_{kmax} \cdot \frac{I_{sn}}{I_{pn}} \cdot \left( R_{CT} + R_L + \frac{S_R}{I_r^2} \right)$$

Equation 9.3

$$E_{al} \geq E_{alreq} = 2 \cdot I_{tmax} \cdot \frac{I_{sn}}{I_{pn}} \cdot \left( R_{CT} + R_L + \frac{S_R}{I_r^2} \right)$$

Equation 9.4

where

$I_{kmax}$  Maximum primary fundamental frequency fault current for internal close-in faults (A).

$I_{tmax}$  Maximum primary fundamental frequency fault current for through fault current for external faults (A).

$I_{pn}$  The rated primary CT current (A).

$I_{sn}$  The rated secondary CT current (A).

$I_r$  The rated current of the protection IED (A).

$R_{CT}$  The secondary resistance of the CT ( $\Omega$ ).

$R_L$  The resistance of the secondary wire and additional load ( $\Omega$ ). The loop resistance containing the phase and neutral wires must be used for faults in solidly earthed systems. The resistance of a single secondary wire should be used for faults in high impedance earthed systems.

$S_R$  The burden of a REX670 current input channel (VA).

$S_R = 0.020$  VA/channel for  $I_r = 1$  A and  $S_R = 0.150$  VA/channel for  $I_r = 5$  A

In substations with breaker-and-a-half or double-busbar double-breaker arrangement, the through fault current may pass two main CTs for the line differential protection without passing the protected line. In such cases and if both main CTs have equal ratios and magnetization characteristics the CTs must satisfy requirement (Equation 9.3) and requirement (Equation 9.5) below:

$$E_{al} \geq E_{alreq} = I_{fdb} \cdot \frac{I_{sn}}{I_{pn}} \cdot \left( R_{CT} + R_L + \frac{S_R}{I_r^2} \right)$$

Equation 9.5

where

$I_{fdb}$  Maximum primary fundamental frequency through fault current that passes two main CTs (one-and-a-half or double-breaker) without passing the protected line (A).

## 9. Protective relays

If a power transformer is included in the protected zone of the line differential protection the CTs must also fulfill the requirement (Equation 9.6) below:

$$E_{al} \geq E_{alreq} = 30 \cdot I_{nt} \cdot \frac{I_{sn}}{I_{pn}} \cdot \left( R_{CT} + R_L + \frac{S_R}{I_r^2} \right)$$

Equation 9.6

where

$I_{nt}$  The rated primary current of the power transformer (A).

### 9.6.2.2 Line distance function

If RED670 is equipped with the line distance function the CTs must also fulfill the following requirements. The CTs must have a rated equivalent secondary e.m.f.  $E_{al}$  that is larger than or equal to the maximum of the required secondary e.m.f.  $E_{alreq}$  below:

$$E_{al} \geq E_{alreq} = \frac{I_{kmax} \cdot I_{sn}}{I_{pn}} \cdot a \cdot \left( R_{CT} + R_L + \frac{S_R}{I_r^2} \right)$$

Equation 9.7

$$E_{al} \geq E_{alreq} = \frac{I_{kzone1} \cdot I_{sn}}{I_{pn}} \cdot k \cdot \left( R_{CT} + R_L + \frac{S_R}{I_r^2} \right)$$

Equation 9.8

where

$I_{kmax}$  Maximum primary fundamental frequency current for close-in forward and reverse faults (A).

$I_{kzone1}$  Maximum primary fundamental frequency current for faults at the end of zone 1 reach (A).

$I_{pn}$  The rated primary CT current (A).

$I_{sn}$  The rated secondary CT current (A).

$I_r$  The rated current of the protection IED (A).

$R_{CT}$  The secondary resistance of the CT ( $\Omega$ ).

$R_L$  The resistance of the secondary wire and additional load ( $\Omega$ ). In solidly earthed systems the loop resistance containing the phase and neutral wires should be used for phase-to-earth faults and the resistance of the phase wire should be used for three-phase faults. In isolated or high impedance earthed systems the resistance of the single secondary wire always can be used.

$S_R$  The burden of a REX670 current input channel (VA).

$S_R = 0.020$  VA/channel for  $I_r = 1$  A and  $S_R = 0.150$  VA/channel for  $I_r = 5$  A



$a$	This factor is a function of the primary time constant for the dc component in the fault current.
$a = 2$	for the primary time constant $T_p \leq 50$ ms
$a = 3$	for the primary time constant $T_p > 50$ ms
$k$	A factor of the primary time constant for the dc component in the fault current for a three-phase fault at the set reach of zone 1.
$a = 4$	for the primary time constant $T_p \leq 30$ ms
$a = 6$	for the primary time constant $T_p > 30$ ms

### 9.6.3 Transformer protection RET670 and RET650

#### 9.6.3.1 Transformer differential function

The CTs must have a rated equivalent secondary e.m.f.  $E_{al}$  that is larger than or equal to the maximum of the required secondary e.m.f.  $E_{alreq}$  below:

$$E_{al} \geq E_{alreq} = 30 \cdot I_{nt} \cdot \frac{I_{sn}}{I_{pn}} \cdot \left( R_{CT} + R_L + \frac{S_R}{I_r^2} \right)$$

Equation 9.9

$$E_{al} \geq E_{alreq} = 2 \cdot I_{tf} \cdot \frac{I_{sn}}{I_{pn}} \cdot \left( R_{CT} + R_L + \frac{S_R}{I_r^2} \right)$$

Equation 9.10

where

$I_{nt}$	The rated primary current of the power transformer (A).
$I_{tf}$	Maximum primary fundamental frequency current that passes two main CTs and the power transformer (A).
$I_{pn}$	The rated primary CT current (A).
$I_{sn}$	The rated secondary CT current (A).
$I_r$	The rated current of the protection IED (A).
$R_{CT}$	The secondary resistance of the CT ( $\Omega$ ).
$R_L$	The resistance of the secondary wire and additional load ( $\Omega$ ). The loop resistance containing the phase and neutral wires must be used for faults in solidly earthed systems. The resistance of a single secondary wire should be used for faults in high impedance earthed systems.
$S_R$	The burden of a REX670 current input channel (VA). RET670: $S_R = 0.020$ VA/channel for $I_r = 1$ A and $S_R = 0.150$ VA/channel for $I_r = 5$ A RET650: $S_R = 0.010$ VA/channel for $I_r = 1$ A and $S_R = 0.250$ VA/channel for $I_r = 5$ A

## 9. Protective relays

In substations with breaker-and-a-half or double-busbar double-breaker arrangement, the fault current may pass two main CTs for the transformer differential protection without passing the power transformer. In such cases and if both main CTs have equal ratios and magnetization characteristics the CTs must satisfy Requirement (Equation 9.9) and the Requirement (Equation 9.11) below:

$$E_{al} \geq E_{alreq} = I_f \cdot \frac{I_{sn}}{I_{pn}} \cdot \left( R_{CT} + R_L + \frac{S_R}{I_r^2} \right)$$

Equation 9.11

where

$I_f$  Maximum primary fundamental frequency current that passes two main CTs without passing the power transformer (A).

### 9.6.3.2 Restricted earth fault protection (low impedance differential)

The requirements are specified separately for solidly earthed and impedance earthed transformers. For impedance earthed transformers the requirements for the phase CTs are depending whether it is three individual CTs connected in parallel or it is a cable CT enclosing all three phases.

#### Neutral CTs and phase CTs for solidly earthed transformers

The neutral CT and the phase CTs must have a rated equivalent secondary e.m.f.  $E_{al}$  that is larger than or equal to the maximum of the required secondary e.m.f.  $E_{alreq}$  below:

$$E_{al} \geq E_{alreq} = 30 \cdot I_{nt} \cdot \frac{I_{sn}}{I_{pn}} \cdot \left( R_{CT} + R_L + \frac{S_R}{I_r^2} \right)$$

Equation 9.12

$$E_{al} \geq E_{alreq} = 2 \cdot I_{etf} \cdot \frac{I_{sn}}{I_{pn}} \cdot \left( R_{CT} + R_L + \frac{S_R}{I_r^2} \right)$$

Equation 9.13

where

$I_{nt}$  The rated primary current of the power transformer (A).

$I_{etf}$  Maximum primary fundamental frequency phase-to-earth fault current that passes the CTs and the power transformer neutral (A).

$I_{pn}$  The rated primary CT current (A).

$I_{sn}$  The rated secondary CT current (A).

$I_r$	The rated current of the protection IED (A).
$R_{CT}$	The secondary resistance of the CT ( $\Omega$ ).
$R_L$	The resistance of the secondary wire and additional load ( $\Omega$ ). The loop resistance containing the phase and neutral wires shall be used.
$S_R$	The burden of a REX670 current input channel (VA). RET670: $S_R = 0.020$ VA/channel for $I_r = 1$ A and $S_R = 0.150$ VA/channel for $I_r = 5$ A RET650: $S_R = 0.010$ VA/channel for $I_r = 1$ A and $S_R = 0.250$ VA/channel for $I_r = 5$ A

In substations with breaker-and-a-half or double-busbar double-breaker arrangement, the fault current may pass two main phase CTs for the restricted earth fault protection without passing the power transformer. In such cases and if both main CTs have equal ratios and magnetization characteristics the CTs must satisfy Requirement (Equation 9.12) and the Requirement (Equation 9.14) below:

$$E_{al} \geq E_{alreq} = I_{ef} \cdot \frac{I_{sn}}{I_{pn}} \cdot \left( R_{CT} + R_L + \frac{S_R}{I_r^2} \right)$$

Equation 9.14

where

$I_{ef}$	Maximum primary fundamental frequency phase-to-earth fault current that passes two main CTs without passing the power transformer neutral (A).
----------	--

### Neutral CTs and phase CTs for impedance earthed transformers

The neutral CT and phase CTs must have a rated equivalent secondary e.m.f.  $E_{al}$  that is larger than or equal to the required secondary e.m.f.  $E_{alreq}$  below:

$$E_{al} \geq E_{alreq} = 3 \cdot I_{ef} \cdot \frac{I_{sn}}{I_{pn}} \cdot \left( R_{CT} + R_L + \frac{S_R}{I_r^2} \right)$$

Equation 9.15

where

$I_{ef}$	Maximum primary fundamental frequency phase-to-earth fault current that passes two main CTs without passing the power transformer neutral (A).
$I_{pn}$	The rated primary CT current (A).
$I_{sn}$	The rated secondary CT current (A).
$I_r$	The rated current of the protection IED (A).
$R_{CT}$	The secondary resistance of the CT ( $\Omega$ ).
$R_L$	The resistance of the secondary wire and additional load ( $\Omega$ ). The loop resistance containing the phase and neutral wires shall be used.
$S_R$	The burden of a REX670 current input channel (VA). RET670: $S_R = 0.020$ VA/channel for $I_r = 1$ A and $S_R = 0.150$ VA/channel for $I_r = 5$ A RET650: $S_R = 0.010$ VA/channel for $I_r = 1$ A and $S_R = 0.250$ VA/channel for $I_r = 5$ A

## 9. Protective relays

In case of three individual CTs connected in parallel (Holmgren connection) on the phase side the following additional requirements must also be fulfilled.

The three individual phase CTs must have a rated equivalent secondary e.m.f.  $E_{al}$  that is larger than or equal to the maximum of the required secondary e.m.f.  $E_{alreq}$  below:

$$E_{al} \geq E_{alreq} = 2 \cdot I_{yf} \cdot \frac{I_{sn}}{I_{pn}} \cdot \left( R_{CT} + R_{Lsw} + \frac{S_R}{I_r^2} \right)$$

Equation 9.16

where

$I_{yf}$  Maximum primary fundamental frequency three-phase fault current that passes the CTs and the power transformer (A).

$R_{Lsw}$  The resistance of the single secondary wire and additional load ( $\Omega$ ).

In impedance earthed systems the phase-to-earth fault currents often are relatively small and the requirements might result in small CTs. However, in applications where the zero sequence current from the phase side of the transformer is a summation of currents from more than one CT (cable CTs or groups of individual CTs in Holmgren connection) e.g. in substations with breaker-and-a-half or double-busbar double-breaker arrangement or if the transformer has a T-connection to different busbars, there is a risk that the CTs can be exposed for higher fault currents than the considered phase-to-earth fault currents above. Examples of such cases can be cross-country faults or phase-to-phase faults with high fault currents and unsymmetrical distribution of the phase currents between the CTs. The zero sequence fault current level can differ much and is often difficult to calculate or estimate for different cases. To cover these cases, with summation of zero sequence currents from more than one CT, the phase side CTs must fulfill the Requirement (Equation 9.17) below:

$$E_{al} \geq E_{alreq} = I_f \cdot \frac{I_{sn}}{I_{pn}} \cdot \left( R_{CT} + R_L + \frac{S_R}{I_r^2} \right)$$

Equation 9.17

where

$I_f$  Maximum primary fundamental frequency three-phase fault current that passes the CTs (A).

$R_L$  The resistance of the secondary wire and additional load ( $\Omega$ ). The loop resistance containing the phase and neutral wires shall be used.

## 9.6.4 Busbar protection REB670

### 9.6.4.1 Busbar differential function

The CT can be of high remanence or low remanence type and they can be used together within the same zone of protection. Each of them must have a rated equivalent secondary e.m.f.  $E_{al}$  that is larger than or equal to the required secondary e.m.f.  $E_{alreq}$  below:

**The high remanence type CT must fulfill**

$$E_{al} \geq E_{alreq} = 0.5 \cdot I_{f \max} \cdot \frac{I_{sn}}{I_{pn}} \cdot \left( R_{CT} + R_L + \frac{S_R}{I_r^2} \right)$$

Equation 9.18

**The low remanence type CT must fulfill**

$$E_{al} \geq E_{alreq} = 0.2 \cdot I_{f \max} \cdot \frac{I_{sn}}{I_{pn}} \cdot \left( R_{CT} + R_L + \frac{S_R}{I_r^2} \right)$$

Equation 9.19

where

$I_{f \max}$	Maximum primary fundamental frequency fault current on the busbar (A).
$I_{pn}$	The rated primary CT current (A).
$I_{sn}$	The rated secondary CT current (A).
$I_r$	The rated current of the protection IED (A).
$R_{CT}$	The secondary resistance of the CT ( $\Omega$ ).
$R_L$	The resistance of the secondary wire and additional load ( $\Omega$ ). The loop resistance containing the phase and neutral wires must be used for faults in solidly earthed systems. The resistance of a single secondary wire should be used for faults in high impedance earthed systems.
$S_R$	The burden of a REx670 current input channel (VA). $S_R = 0.020$ VA/channel for $I_r = 1$ A and $S_R = 0.150$ VA/channel for $I_r = 5$ A

**The non remanence type CT**

CTs of non remanence type (e.g. TPZ) can be used but in this case all the CTs within the differential zone must be of non remanence type. They must fulfill the same requirement as for the low remanence type CTs and have a rated equivalent secondary e.m.f.  $E_{al}$  that is larger than or equal to the required secondary e.m.f.  $E_{alreq}$  below:

$$E_{al} \geq E_{alreq} = 0.2 \cdot I_{f \max} \cdot \frac{I_{sn}}{I_{pn}} \cdot \left( R_{CT} + R_L + \frac{S_R}{I_r^2} \right)$$

Equation 9.20

## 9. Protective relays

### 9.6.4.2 Breaker failure protection

The CTs must have a rated equivalent secondary e.m.f.  $E_{al}$  that is larger than or equal to the required secondary e.m.f.  $E_{alreq}$  below:

$$E_{al} \geq E_{alreq} = 5 \cdot I_{op} \cdot \frac{I_{sn}}{I_{pn}} \cdot \left( R_{CT} + R_L + \frac{S_R}{I_r^2} \right)$$

Equation 9.21

where

$I_{op}$	The primary operate value (A).
$I_{pn}$	The rated primary CT current (A).
$I_{sn}$	The rated secondary CT current (A).
$I_r$	The rated current of the protection IED (A).
$R_{CT}$	The secondary resistance of the CT ( $\Omega$ ).
$R_L$	The resistance of the secondary wire and additional load ( $\Omega$ ). The loop resistance containing the phase and neutral wires must be used for faults in solidly earthed systems. The resistance of a single secondary wire should be used for faults in high impedance earthed systems.
$S_R$	The burden of a REX670 current input channel (VA). $S_R = 0.020$ VA/channel for $I_r = 1$ A and $S_R = 0.150$ VA/channel for $I_r = 5$ A

### 9.6.4.3 Non-directional instantaneous and definitive time, phase overcurrent protection

The CTs must have a rated equivalent secondary e.m.f.  $E_{al}$  that is larger than or equal to the required secondary e.m.f.  $E_{alreq}$  below:

$$E_{al} \geq E_{alreq} = 1.5 \cdot I_{op} \cdot \frac{I_{sn}}{I_{pn}} \cdot \left( R_{CT} + R_L + \frac{S_R}{I_r^2} \right)$$

Equation 9.22

where

$I_{op}$	The primary operate value (A).
$I_{pn}$	The rated primary CT current (A).
$I_{sn}$	The rated secondary CT current (A).
$I_r$	The rated current of the protection IED (A).
$R_{CT}$	The secondary resistance of the CT ( $\Omega$ ).
$R_L$	The resistance of the secondary wire and additional load ( $\Omega$ ). The loop resistance containing the phase and neutral wires must be used for faults in solidly earthed systems. The resistance of a single secondary wire should be used for faults in high impedance earthed systems.
$S_R$	The burden of a REX670 current input channel (VA). $S_R = 0.020$ VA/channel for $I_r = 1$ A and $S_R = 0.150$ VA/channel for $I_r = 5$ A

#### 9.6.4.4 Non-directional inverse time delayed phase overcurrent protection

The requirement according to (Equation 9.23) and (Equation 9.24) does not need to be fulfilled if the high set instantaneous or definitive time stage is used. In this case (Equation 9.22) is the only necessary requirement.

If the inverse time delayed function is the only used overcurrent protection function the CTs must have a rated equivalent secondary e.m.f.  $E_{al}$  that is larger than or equal to the required secondary e.m.f.  $E_{alreq}$  below:

$$E_{al} \geq E_{alreq} = 20 \cdot I_{op} \cdot \frac{I_{sn}}{I_{pn}} \cdot \left( R_{CT} + R_L + \frac{S_R}{I_r^2} \right)$$

Equation 9.23

where

$I_{op}$	The primary current set value of the inverse time function (A).
$I_{pn}$	The rated primary CT current (A).
$I_{sn}$	The rated secondary CT current (A).
$I_r$	The rated current of the protection IED (A).
$R_{CT}$	The secondary resistance of the CT ( $\Omega$ ).
$R_L$	The resistance of the secondary wire and additional load ( $\Omega$ ). The loop resistance containing the phase and neutral wires must be used for faults in solidly earthed systems. The resistance of a single secondary wire should be used for faults in high impedance earthed systems.
$S_R$	The burden of a REx670 current input channel (VA). $S_R = 0.020$ VA/channel for $I_r = 1$ A and $S_R = 0.150$ VA/channel for $I_r = 5$ A

Independent of the value of  $I_{op}$  the maximum required  $E_{al}$  is specified according to the following:

$$E_{al} \geq E_{alreqmax} = I_{kmax} \cdot \frac{I_{sn}}{I_{pn}} \cdot \left( R_{CT} + R_L + \frac{S_R}{I_r^2} \right)$$

Equation 9.24

where

$I_{kmax}$	Maximum primary fundamental frequency current for close-in faults (A).
------------	--

# 9. Protective relays

## 9.6.5 Bay control REC670 and REC650

### 9.6.5.1 Circuit breaker failure protection

The CTs must have a rated equivalent secondary e.m.f.  $E_{al}$  that is larger than or equal to the required secondary e.m.f.  $E_{alreq}$  below:

$$E_{al} \geq E_{alreq} = 5 \cdot I_{op} \cdot \frac{I_{sn}}{I_{pn}} \cdot \left( R_{CT} + R_L + \frac{S_R}{I_r^2} \right)$$

Equation 9.25

where

$I_{op}$	The primary operate value (A).
$I_{pn}$	The rated primary CT current (A).
$I_{sn}$	The rated secondary CT current (A).
$I_r$	The rated current of the protection IED (A).
$R_{CT}$	The secondary resistance of the CT ( $\Omega$ ).
$R_L$	The resistance of the secondary wire and additional load ( $\Omega$ ). The loop resistance containing the phase and neutral wires must be used for faults in solidly earthed systems. The resistance of a single secondary wire should be used for faults in high impedance earthed systems.
$S_R$	The burden of one current input channel (VA). REC670: $S_R = 0.020$ VA/channel for $I_r = 1$ A and $S_R = 0.150$ VA/channel for $I_r = 5$ A REC650: $S_R = 0.010$ VA/channel for $I_r = 1$ A and $S_R = 0.250$ VA/channel for $I_r = 5$ A

### 9.6.5.2 Non-directional instantaneous and definitive time, phase and residual overcurrent protection

The CTs must have a rated equivalent secondary e.m.f.  $E_{al}$  that is larger than or equal to the required secondary e.m.f.  $E_{alreq}$  below:

$$E_{al} \geq E_{alreq} = 1.5 \cdot I_{op} \cdot \frac{I_{sn}}{I_{pn}} \cdot \left( R_{CT} + R_L + \frac{S_R}{I_r^2} \right)$$

Equation 9.26

where

$I_{op}$	The primary operate value (A).
$I_{pn}$	The rated primary CT current (A).
$I_{sn}$	The rated secondary CT current (A).
$I_r$	The rated current of the protection IED (A).
$R_{CT}$	The secondary resistance of the CT ( $\Omega$ ).
$R_L$	The resistance of the secondary wire and additional load ( $\Omega$ ). The loop resistance containing the phase and neutral wires must be used for faults in solidly earthed systems. The resistance of a single secondary wire should be used for faults in high impedance earthed systems.



$S_R$	The burden of one current input channel (VA). REC670: $S_R = 0.020$ VA/channel for $I_r = 1$ A and $S_R = 0.150$ VA/channel for $I_r = 5$ A REC650: $S_R = 0.010$ VA/channel for $I_r = 1$ A and $S_R = 0.250$ VA/channel for $I_r = 5$ A
-------	---

### 9.6.5.3 Non-directional inverse time delayed phase and residual overcurrent protection

The requirement according to (Equation 9.27) and (Equation 9.28) does not need to be fulfilled if the high set instantaneous or definitive time stage is used. In this case (Equation 9.26) is the only necessary requirement.

If the inverse time delayed function is the only used overcurrent protection function the CTs must have a rated equivalent secondary e.m.f.  $E_{al}$  that is larger than or equal to the required secondary e.m.f.  $E_{alreq}$  below:

$$E_{al} \geq E_{alreq} = 20 \cdot I_{op} \cdot \frac{I_{sn}}{I_{pn}} \cdot \left( R_{CT} + R_L + \frac{S_R}{I_r^2} \right)$$

Equation 9.27

where

$I_{op}$	The primary current set value of the inverse time function (A).
$I_{pn}$	The rated primary CT current (A).
$I_{sn}$	The rated secondary CT current (A).
$I_r$	The rated current of the protection IED (A).
$R_{CT}$	The secondary resistance of the CT ( $\Omega$ ).
$R_L$	The resistance of the secondary wire and additional load ( $\Omega$ ). The loop resistance containing the phase and neutral wires must be used for faults in solidly earthed systems. The resistance of a single secondary wire should be used for faults in high impedance earthed systems.
$S_R$	The burden of one current input channel (VA). REC670: $S_R = 0.020$ VA/channel for $I_r = 1$ A and $S_R = 0.150$ VA/channel for $I_r = 5$ A REC650: $S_R = 0.010$ VA/channel for $I_r = 1$ A and $S_R = 0.250$ VA/channel for $I_r = 5$ A

Independent of the value of  $I_{op}$  the maximum required  $E_{al}$  is specified according to the following:

$$E_{al} \geq E_{alreqmax} = I_{kmax} \cdot \frac{I_{sn}}{I_{pn}} \cdot \left( R_{CT} + R_L + \frac{S_R}{I_r^2} \right)$$

Equation 9.28

where

$I_{kmax}$	Maximum primary fundamental frequency current for close-in faults (A).
------------	--

## 9. Protective relays

### 9.6.5.4 Directional phase and residual overcurrent protection

If the directional overcurrent function is used the CTs must have a rated equivalent secondary e.m.f.  $E_{al}$  that is larger than or equal to the required secondary e.m.f.  $E_{alreq}$  below:

$$E_{al} \geq E_{alreq} = I_{kmax} \cdot \frac{I_{sn}}{I_{pn}} \cdot \left( R_{CT} + R_L + \frac{S_R}{I_r^2} \right)$$

Equation 9.29

where

$I_{kmax}$	Maximum primary fundamental frequency current for close-in forward and reverse faults (A).
$I_{pn}$	The rated primary CT current (A).
$I_{sn}$	The rated secondary CT current (A).
$I_r$	The rated current of the protection IED (A).
$R_{CT}$	The secondary resistance of the CT ( $\Omega$ ).
$R_L$	The resistance of the secondary wire and additional load ( $\Omega$ ). The loop resistance containing the phase and neutral wires must be used for faults in solidly earthed systems. The resistance of a single secondary wire should be used for faults in high impedance earthed systems.
$S_R$	The burden of one current input channel (VA). REC670: $S_R = 0.020$ VA/channel for $I_r = 1$ A and $S_R = 0.150$ VA/channel for $I_r = 5$ A REC650: $S_R = 0.010$ VA/channel for $I_r = 1$ A and $S_R = 0.250$ VA/channel for $I_r = 5$ A

### 9.6.6 Line distance protection REL501, REL511, REL521, REL531

#### 9.6.6.1 Line distance function

The current transformers must have a rated equivalent secondary e.m.f.  $E_{al}$  that is larger than the maximum of the required secondary e.m.f.  $E_{alreq}$  below:

$$E_{al} > E_{alreq} = \frac{I_{kmax} \cdot I_{sn}}{I_{pn}} \cdot a \cdot \left( R_{CT} + R_L + \frac{0.25}{I_r^2} \right)$$

Equation 9.30

where

$I_{kmax}$	Maximum primary fundamental frequency current for close-in forward and reverse faults (A).
$I_{kzone1}$	Maximum primary fundamental frequency current for faults at the end of zone 1 reach (A).
$I_{pn}$	The rated primary CT current (A).
$I_{sn}$	The rated secondary CT current (A).
$I_R$	The protection terminal rated current (A).
$R_{CT}$	The secondary resistance of the CT ( $\Omega$ ).
$R_L$	The resistance of the secondary cable and additional load ( $\Omega$ ). The loop resistance should be used for phase-to-earth faults and the phase resistance for three-phase faults.
$a$	This factor is a function of the network frequency and the primary time constant for the dc component in the fault current. $a = 2$ for the primary time constant $T_p \leq 50$ ms, 50 and 60 Hz $a = 3$ for the primary time constant $T_p > 50$ ms, 50 Hz $a = 4$ for the primary time constant $T_p > 50$ ms, 60 Hz
$k$	A factor of the network frequency and the primary time constant for the dc component in the fault current for a three-phase fault at the set reach of zone 1. The time constant is normally less than 50 ms. $k = 4$ for the primary time constant $T_p \leq 30$ ms, 50 and 60 Hz $k = 6$ for the primary time constant $T_p > 30$ ms, 50 Hz $k = 7$ for the primary time constant $T_p > 30$ ms, 60 Hz

## 9.6.7 Line differential protection REL551 and REL561

### 9.6.7.1 Line differential function

The current transformers must have a rated equivalent secondary e.m.f.  $E_{al}$  that is larger than the maximum of the required secondary e.m.f.  $E_{alreq}$  below. The requirements according to the formulas below are valid for fault currents with a primary time constant less than 120 ms.

$$E_{al} > E_{alreq} = \frac{I_{kmax} \cdot I_{sn}}{I_{pn}} \cdot 0.5 \cdot \left( R_{CT} + R_L + \frac{0.25}{I_r^2} \right)$$

Equation 9.31

$$E_{al} > E_{alreq} = \frac{I_{tmax} \cdot I_{sn}}{I_{pn}} \cdot 2 \cdot \left( R_{CT} + R_L + \frac{0.25}{I_r^2} \right)$$

Equation 9.32

## 9. Protective relays

where

$I_{kmax}$	Maximum primary fundamental frequency fault current for internal close-in faults (A).
$I_{imax}$	Maximum primary fundamental frequency fault current for through fault current for external faults (A).
$I_{pn}$	The rated primary CT current (A).
$I_{sn}$	The rated secondary CT current (A).
$I_r$	The protection terminal rated current (A).
$R_{CT}$	The secondary resistance of the CT ( $\Omega$ ).
$R_L$	The loop resistance of the secondary cable and additional load ( $\Omega$ ).

The factor 0.5 in equation 31 is replaced with 0.53 and 0.54 for primary time constants of 200 ms and 300 ms respectively.

The factor 2 in equation 32 is replaced with 2.32 and 2.5 for primary time constants of 200 ms and 300 ms respectively.

Additional requirements according to the equations 9.33 and 9.34 below must also be fulfilled.

$$E_{al} > E_{alreq} = 0.12 \cdot f \cdot I_{sn} \cdot \left( R_{CT} + R_L + \frac{0.25}{I_r^2} \right)$$

Equation 9.33

$$E_{al} > E_{alreq} = \frac{I_{minSat}}{100} \cdot CT_{Factor} \cdot I_r \cdot \left( R_{CT} + R_L + \frac{0.25}{I_r^2} \right)$$

Equation 9.34

where

$f$	Nominal frequency (Hz).
$I_{sn}$	The rated secondary CT current (A).
$I_r$	The protection terminal rated current (A).
$R_{CT}$	The secondary resistance of the CT ( $\Omega$ ).
$R_L$	The loop resistance of the secondary cable and additional load ( $\Omega$ ).
$I_{minSat}$	Set saturation detector min current (100-1000% of $I_R$ ).
$CT_{Factor}$	Set current scaling factor (0.4-1.0).

Requirements (Equation 9.33) and (Equation 9.34) are independent of the primary time constant.

### 9.6.7.2 Line distance function, additional for REL561

If REL 561 is equipped with the line distance function the CTs must also fulfill the following requirements. The CTs must have a rated equivalent secondary e.m.f.  $E_{al}$  that is larger than or equal to the maximum of the required secondary e.m.f.  $E_{alreq}$  below:

$$E_{al} > E_{alreq} = \frac{I_{kmax} \cdot I_{sn}}{I_{pn}} \cdot a \cdot \left( R_{CT} + R_L + \frac{0.25}{I_r^2} \right)$$

Equation 9.35

$$E_{al} > E_{alreq} = \frac{I_{kzone1} \cdot I_{sn}}{I_{pn}} \cdot k \cdot \left( R_{CT} + R_L + \frac{0.25}{I_r^2} \right)$$

Equation 9.36

where

$I_{kmax}$	Maximum primary fundamental frequency current for close-in forward and reverse faults (A).
$I_{kzone1}$	Maximum primary fundamental frequency current for faults at the end of zone 1 reach (A).
$I_{pn}$	The rated primary CT current (A).
$I_{sn}$	The rated secondary CT current (A).
$I_r$	The protection terminal rated current (A).
$R_{CT}$	The secondary resistance of the CT ( $\Omega$ ).
$R_L$	The resistance of the secondary cable and additional load ( $\Omega$ ). The loop resistance should be used for phase-to-earth faults and the phase resistance for three-phase faults.
$a$	This factor is a function of the network frequency and the primary time constant for the dc component in the fault current. $a = 2$ for the primary time constant $T_p \leq 50$ ms, 50 and 60 Hz $a = 3$ for the primary time constant $T_p > 50$ ms, 50 Hz $a = 4$ for the primary time constant $T_p > 50$ ms, 60 Hz
$k$	A factor of the network frequency and the primary time constant for the dc component in the fault current for a three-phase fault at the set reach of zone 1. The time constant is normally less than 50 ms. $k = 4$ for the primary time constant $T_p \leq 30$ ms, 50 and 60 Hz $k = 6$ for the primary time constant $T_p > 30$ ms, 50 Hz $k = 7$ for the primary time constant $T_p > 30$ ms, 60 Hz

## 9. Protective relays

### 9.6.8 Transformer protection RET 521 and transformer differential protection RADSB

To avoid maloperation on energization of the power transformer and in connection with fault current that passes through the power transformer, the rated equivalent limiting secondary e.m.f.  $E_{al}$  of the CTs must be larger than or equal to the maximum of the required secondary e.m.f.  $E_{alreq}$  below:

$$E_{al} \geq E_{alreq} = 30 \cdot I_{nt} \cdot (R_{CT} + k + R_L + Z_r)$$

Equation 9.37

$$E_{al} \geq E_{alreq} = 2 \cdot I_{ff} \cdot (R_{CT} + k + R_L + Z_r)$$

Equation 9.38

where

$I_{nt}$	The main CT secondary current corresponding to the rated current of the power transformer (A).
$I_{ff}$	The maximum secondary side fault current that passes two main CTs and the power transformer (A).
$I_r$	The protection relay rated current (A).
$R_{CT}$	The secondary resistance of the CT ( $\Omega$ ).
$Z_r$	The burden of the relay ( $\Omega$ ):

$$\text{RET 521: } Z_r = \frac{0.25}{I_r^2} (\Omega)$$

RADSB: The reflected burden of the relay and the loop resistance of the wires from the interposing CTs (when used) to the relay.

$R_L$	The resistance of a single secondary wire from the main CT to the relay (or, in case of RADSB, to the interposing CTs when used) and additional load ( $\Omega$ ).
$k$	A factor depending of the system earthing. k = 1 for high impedance earthed systems k = 2 for a solidly earthed system

In substations with breaker-and-a-half or double-busbar double-breaker arrangement, the fault current may pass two main CTs for the transformer differential protection without passing the power transformer. In such cases, the CTs must satisfy requirement (Equation 9.37) and the requirement (Equation 9.39) below:

$$E_{al} \geq E_{alreq} = I_f \cdot (R_{CT} + k + R_L + Z_r)$$

Equation 9.39

where

$I_f$	The maximum secondary side fault current that passes two main CTs without passing the power transformer (A).
-------	--

Requirement (Equation 9.39) applies to the case when both main CTs have equal transformation ratio and magnetization characteristics.

### 9.6.9 Busbar protection RED521

The CT can be of high remanence or low remanence type and they can be used together within the same zone of protection. Each of them must have a rated equivalent secondary e.m.f.  $E_{al}$  that is larger than or equal to the required secondary e.m.f.  $E_{alreq}$  below:

**The high remanence type CT must fulfill**

$$E_{al} \geq E_{alreq} = 0.5 \cdot I_{f \max} \cdot \frac{I_{sn}}{I_{pn}} \cdot \left( R_{CT} + R_L \frac{0.25}{I_r^2} \right)$$

Equation 9.40

**The low remanence type CT must fulfill**

$$E_{al} \geq E_{alreq} = 0.2 \cdot I_{f \max} \cdot \frac{I_{sn}}{I_{pn}} \cdot \left( R_{CT} + R_L \frac{0.25}{I_r^2} \right)$$

Equation 9.41

where

$I_{f \max}$	Maximum primary fundamental frequency fault current on the busbar (A).
$I_{pn}$	The rated primary CT current (A).
$I_{sn}$	The rated secondary CT current (A).
$I_r$	The rated current of the protection IED (A).
$R_{CT}$	The secondary resistance of the CT ( $\Omega$ ).
$R_L$	The resistance of the secondary wire and additional load ( $\Omega$ ). The loop resistance containing the phase and neutral wires must be used for faults in solidly earthed systems. The resistance of a single secondary wire should be used for faults in high impedance earthed systems.

**The non remanence type CT**

CTs of non remanence type (e.g. TPZ) can be used but in this case all the CTs within the differential zone must be of non remanence type. They must fulfill the same requirement as for the low remanence type CTs and have a rated equivalent secondary e.m.f.  $E_{al}$  that is larger than or equal to the required secondary e.m.f.  $E_{alreq}$  below:

$$E_{al} \geq E_{alreq} = 0.2 \cdot I_{f \max} \cdot \frac{I_{sn}}{I_{pn}} \cdot \left( R_{CT} + R_L \frac{0.25}{I_r^2} \right)$$

Equation 9.42

## 9. Protective relays

### 9.6.10 High impedance differential protection RADHA

The CTs connected to the RADHA must have a rated equivalent secondary e.m.f.  $E_{al}$  that is larger than or equal to the required secondary e.m.f.  $E_{alreq}$  below:

$$E_{al} \geq E_{alreq} = 2 \cdot U_s = 2 \cdot I_{tmax} \cdot \frac{I_{sn}}{I_{pn}} \cdot (R_{CT} + R_L)$$

Equation 9.43

where

$U_s$	Set operate value of the voltage relay (V).
$I_{max}$	Maximum primary fundamental frequency fault current for through fault current for external faults (A).
$I_{pn}$	The rated primary CT current (A).
$I_{sn}$	The rated secondary CT current (A).
$R_{CT}$	The secondary resistance of the CT ( $\Omega$ ).
$R_L$	The resistance of the secondary cable from the CT up to a common junction point ( $\Omega$ ). The loop resistance containing the phase and neutral wires must be used for faults in solidly earthed systems and the resistance of a single-phase wire should be used for faults in high impedance earthed systems.

All CTs to the same protection should have identical turn ratios. Consequently auxiliary CTs cannot normally be used. RADHA must be provided with separate cores.

### 9.6.11 Pilot-wire differential relay RADHL

The CTs at each terminal do not need to have the same ratio. Ratio matching can be done with the internal auxiliary summation CT. The CTs must have a rated equivalent secondary e.m.f.  $E_{al}$  that is larger than or equal to the required secondary e.m.f.  $E_{alreq}$  below:

$$E_{al} \geq E_{alreq} = 20 \cdot I_{sn} \cdot \left( R_{CT} + R_L + \frac{5}{I_r^2} \right)$$

Equation 9.44

where

$I_{sn}$	The rated secondary CT current (A).
$I_r$	The protection relay rated current (A).
$R_{CT}$	The secondary resistance of the CT ( $\Omega$ ).
$R_L$	The resistance of the secondary cable and additional load ( $\Omega$ ). The resistance of the cables shall be taken for a single length if the application is in a high impedance earthed system. In a solidly earthed system shall the double length, phase and neutral wires, be considered.



## 9.7 Current transformer requirements for CTs according to other standards

All kinds of conventional magnetic core CTs are possible to use with ABB relays if they fulfill the requirements corresponding to the above specified expressed as the rated equivalent secondary e.m.f.  $E_{al}$  according to the IEC 60044-1 standard. From different standards and available data for relaying applications it is possible to approximately calculate a secondary e.m.f. of the CT comparable with  $E_{al}$ . By comparing this with the required secondary e.m.f.  $E_{alreq}$  it is possible to judge if the CT fulfills the requirements. The requirements according to some other standards are specified below.

### 9.7.1 Current transformers according to IEC 60044-1, class P, PR

A CT according to IEC 60044-1 is specified by the secondary limiting e.m.f.  $E_{2max}$ . The value of the  $E_{2max}$  is approximately equal to the corresponding  $E_{al}$  according to IEC 60044-6. Therefore, the CTs according to class P and PR must have a secondary limiting e.m.f.  $E_{2max}$  that fulfills the following:

$$E_{2max} > \text{maximum of } E_{alreq}$$

Equation 9.45

### 9.7.2 Current transformers according to IEC 60044-1 class PX, IEC 60044-6 class TPS (and old British Standard, class X)

CTs according to these classes are specified approximately in the same way by a rated knee-point e.m.f.  $E_{knee}$  ( $E_k$  for class PX,  $E_{kneeBS}$  for class X and the limiting secondary voltage  $U_{al}$  for TPS). The value of the  $E_{knee}$  is lower than the corresponding  $E_{al}$  according to IEC 60044-6. It is not possible to give a general relation between the  $E_{knee}$  and the  $E_{al}$  but normally the  $E_{knee}$  is approximately 80% of the  $E_{al}$ . Therefore, the CTs according to class PX, X and TPS must have a rated knee-point e.m.f.  $E_{knee}$  that fulfills the following:

$$E_{knee} \approx E_k \approx E_{kneeBS} \approx U_{al} > 0.8 \cdot (\text{maximum of } E_{alreq})$$

Equation 9.46

## 9. Protective relays

### 9.7.3 Current transformers according to ANSI/IEEE

Current transformers according to ANSI/IEEE are partly specified in different ways. A rated secondary terminal voltage  $U_{ANSI}$  is specified for a CT of class C.  $U_{ANSI}$  is the secondary terminal voltage the CT will deliver to a standard burden at 20 times rated secondary current without exceeding 10 % ratio correction. There are a number of standardized  $U_{ANSI}$  values e.g.  $U_{ANSI}$  is 400 V for a C400 CT. A corresponding rated equivalent limiting secondary e.m.f.  $E_{alANSI}$  can be estimated as follows:

$$E_{alANSI} = |20 \cdot I_{sn} \cdot R_{CT} + U_{ANSI}| = |20 \cdot I_{sn} \cdot R_{CT} + 20 \cdot I_{sn} \cdot Z_{bANSI}|$$

Equation 9.47

where

---

$Z_{bANSI}$  The impedance (i.e. complex quantity) of the standard ANSI burden for the specific C class ( $\Omega$ ).

---

$U_{ANSI}$  The rated secondary terminal voltage for the specific C class (V).

---

The CTs according to class C must have a calculated rated equivalent limiting secondary e.m.f.  $E_{alANSI}$  that fulfills the following:

$$E_{alANSI} > \text{maximum of } E_{alreq}$$

Equation 9.48

A CT according to ANSI/IEEE is also specified by the knee-point voltage  $U_{kneeANSI}$  that is graphically defined from an excitation curve. The knee-point voltage  $U_{kneeANSI}$  normally has a lower value than the knee-point e.m.f. according to IEC and BS.  $U_{kneeANSI}$  can approximately be estimated to 75 % of the corresponding  $E_{al}$  according to IEC 60044-6. Therefore, the CTs according to ANSI/IEEE must have a knee-point voltage  $U_{kneeANSI}$  that fulfills the following:

$$E_{kneeANSI} > 0.75 \cdot (\text{maximum of } E_{alreq})$$

Equation 9.49

# 10. Optical current and voltage transducers

ABB currently have several commercial concepts, DOIT, MOCT and FOCS. These are potentially applicable to digital metering and protection when the new IEC 61850 is introduced. Currently, the DOIT is only used in HVDC applications.

The FOCS system are currently available for industrial DC applications. AC applications for metering and protection are being developed.

## 10.1 Fiber Optic Current Sensor FOCS

ABB FOCS is a unique fiber/optic current measurement product using the Faraday effect in an optical fiber: If a magnetic field is applied along the propagation direction of right and left circularly polarized light waves in a medium such as glass, the waves travel at different speeds.

As a result, the waves accumulate a phase difference.

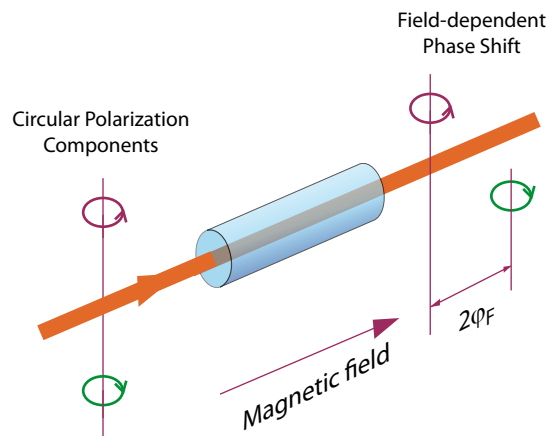

**Figure 10.1**  
Phase shift due to Magnetic field

Two light waves with orthogonal linear polarizations travel from the Sensor Electronics, which include a semiconductor light source, via a sensor fiber cable to the single-ended sensing fiber looped around the current-carrying busbars. A single loop is commonly sufficient for high currents.

At the entrance of the sensing fiber, a fiber-optic phase retarder converts the orthogonal linear waves into left and right circularly polarized light. The circular waves travel through the coil of sensing fiber, are reflected at the end of the fiber and then retrace their optical path back to the coil entrance. Here, they are again converted into orthogonal linearly polarized waves.

# 10. Optical current and voltage transducers

Since the circular waves travel at somewhat different speeds through the sensing fiber if a current is flowing, the two returning light waves have accumulated a phase difference. The phase difference is proportional to the line integral of the magnetic field along the sensing fiber and is therefore a direct measure for the current.

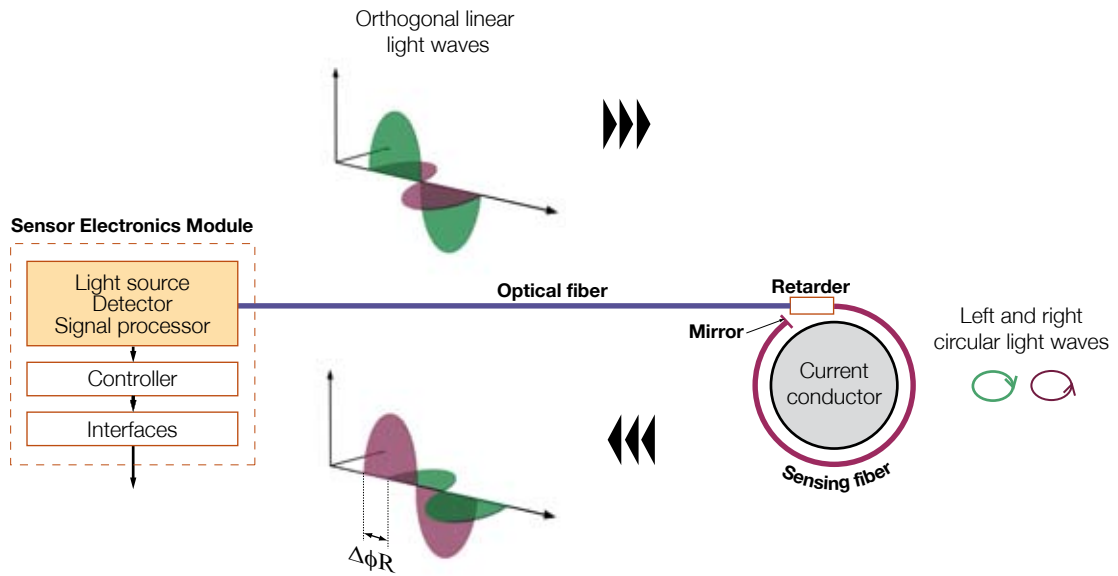

Figure 10.2  
FOCS Measuring principle

The returning waves are brought to interference in the sensor electronics. The signal processor then converts the optical phase difference into a digital signal. A particular advantage of operating the sensing coil in reflection is, besides the simplicity of the arrangement, the fact that the sensor signal is largely immune to mechanical perturbations such as shock and vibration. While the non-reciprocal Faraday optical phase shifts double on the way forwards and backwards, phase shifts caused by mechanical disturbances are reciprocal and cancel each other out.

### Sensor head

The sensor head is connected to the sensor electronics via a glass fiber cable.



Figure 10.3  
Example of FOCS measuring system for DC

### 10.2 MOCT – Technical description

The Magneto-Optic Current Transducer (MOCT) and Electro-Optic Voltage Transducer (EOVT) described here are capable of performing high accuracy (class 0.2 metering) measurements in high- and extra-high-voltage power systems. These offer the advantages of wide accuracy range, optical isolation, reduced weight, flexible installation and safety. The principle of operation of these instrument transformers is based on interaction between a beam of polarized light and an electromagnetic field.

#### MOCT and the Faraday effect

The MOCT is a current measuring device based on the magneto-optical Faraday effect. This effect explains the rotation of the plane of polarization of a linear beam of light in certain materials that become optically active under the presence of a magnetic field. If the magnetic field and light propagation directions coincide, the angle of rotation ( $\theta$ ) is proportional to the magnetic flux density ( $B$ ), the length of the path ( $l$ ) and a constant named *Verdet constant* ( $V$ ), which is a property of the material. In the equation below  $I$  is the current flowing through the conductor and  $\mu$  is the permeability of the material.

$$\theta = V \int B_{dl} = \mu V \int H_{dl} = \mu VI$$

## 10. Optical current and voltage transducers

Figure 10.3 shows the MOCT optical sensor system. Light is emitted by an LED and transmitted through multi mode optical fiber to the rotator installed at high voltage. The light is polarized as it enters the sensor. It then travels around the conductor inserted through the opening on the rotator and exits through an analyzer. The analyzer is oriented  $45^\circ$  with respect to the polarizer. Subsequently, the light is transmitted back through another optical fiber to the electronic module where it is converted into an electric signal by a photodiode (1). The signal processing module and precision amplifier circuit provide an analog 1.0 A output current which is proportional to the primary current flowing through the conductor.

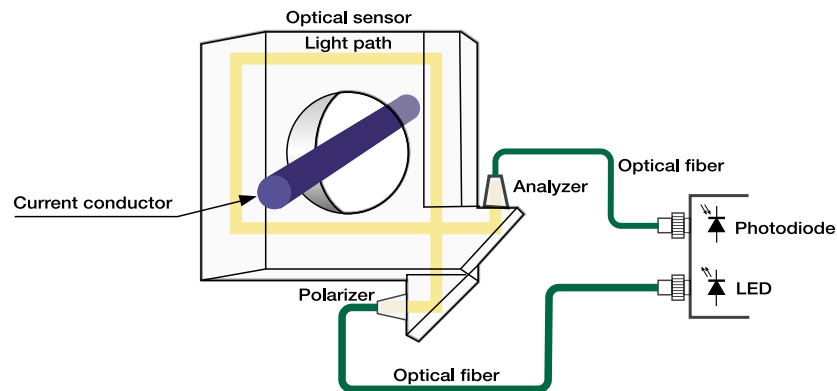

Figure 10.3

### Voltage measurement and the Pockels effect

The voltage sensor operates using a variation of the linear, longitudinal mode electro-optic Pockels effect referred to as the Quadrature Pockels cell. This effect occurs in crystalline materials that exhibit induced birefringence under applied electric field. Linearly polarized light propagating the crystal parallel to the electric field will experience phase retardation between its components in the slow and fast axis. The phase retardation is due to the difference in the velocity of propagation of the light and is related to different refractive indices between these axes.

The voltage sensor consists of a crystal placed between high voltage and ground. The light emitted by a source is transmitted through multi mode optical fiber to the sensor. The beam of light is polarized as it enters the sensor, then it propagates through the crystal in the direction of the electric field. The sensor depicted in Figure 10.4 includes a reflective prism on the high-voltage side of the crystal. This prism reflects the light back towards the grounded side. Therefore, all of the connections are on the ground side. After exiting the sensor, the light is split into two quadrature components, (phase shifted  $90^\circ$ ), which are transmitted back to the electronic module where they are converted into electric signals.

These two signals provide sufficient information to reconstruct the waveform and magnitude of the voltage across the sensor by means of a digital signal processor. The voltage is obtained by interpolating information extracted from segments of the signals and counting their optical fringes. The signal is then amplified to provide a 120 V output proportional to the applied voltage.

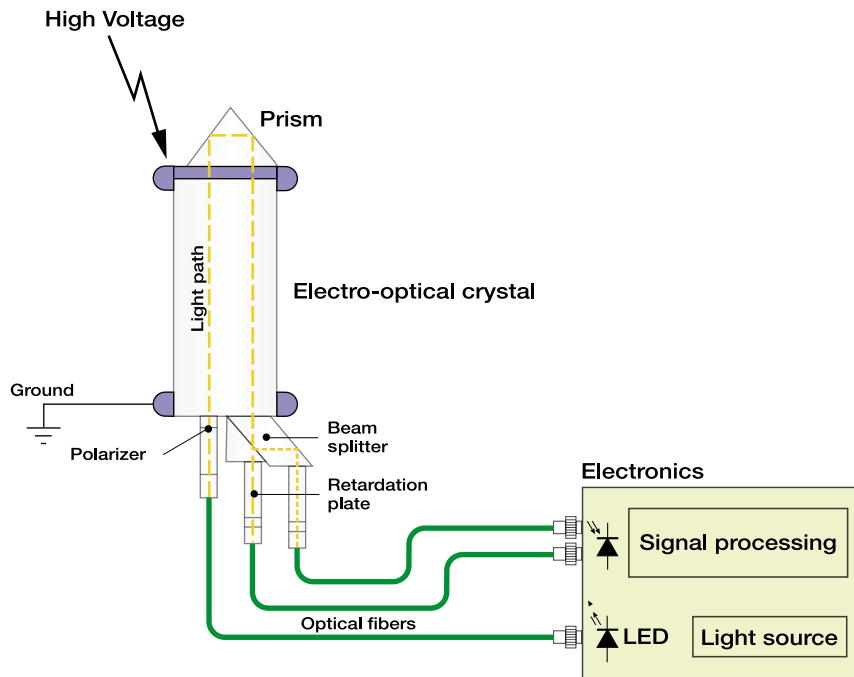

Figure 10.4  
Optical voltage measurement

# Contact us

**ABB AB**  
**High Voltage Products**

SE-771 80 LUDVIKA, SWEDEN  
Phone: +46 (0)240 78 20 00  
Fax: +46 (0)240 78 36 50  
E-Mail: [instr.transf@se.abb.com](mailto:instr.transf@se.abb.com)

[www.abb.com](http://www.abb.com)  
[www.abb.com/highvoltage](http://www.abb.com/highvoltage)

©Copyright 2009 ABB. All rights reserved

NOTE! ABB AB is working continuously to improve the products. We therefore reserve the right to change designs, dimensions and data without prior notice.