

Self-Excited DC Shunt Generator

In **self-excited generator** field coils are energized by the current produced by the generator, the field winding is also connected to the armature winding in varying ways to achieve a wide range of performance characteristics.

For shunt wound type of DC generators the field windings are connected in parallel with armature conductors.

In these generators, the field (excitation) current, and hence magnetic field, increases with operating speed as it is dependent upon the output voltage. The armature voltage and electrical torque also increase with speed. The shunt-wound generator, operating at a constant speed under varying load conditions, has a much more stable voltage output than does the series-wound generator. However, as the load current increases the internal power loss across the armature causes the output voltage to decrease proportionally.

As a result, the current through the field decreases, reducing the magnetic field and causing voltage to decrease even more and if load current is much higher than the design of the generator, the reduction in output voltage becomes so severe resulting in large internal armature losses and overheating of the generator. As a result, **shunt wound DC generators** are not normally used for large constant electrical loads.

The application of shunt generators is very much restricted for its dropping voltage characteristic. They are used to supply power to the apparatus situated very close to its position. These type of DC generators generally give constant terminal voltage for small distance operation with the help of field regulators from no load to full load.

1. They are used for general lighting.
2. They are used to charge battery because they can be made to give constant output voltage.
3. They are used for giving the excitation to the alternators.
4. They are also used for small power supply (such as a portable generator).

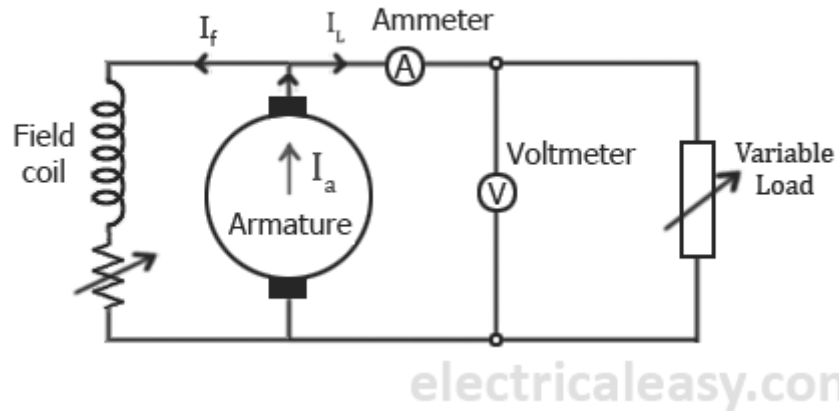

Equations for self-excited shunt wound DC generator:

Here the armature current is divided into two parts:

$$I_a = I_f + I_L.$$

We try to keep the shunt field current as small as possible to have maximum load current which gives us maximum effective power across the load.

while the shunt field current:

$$I_f = V/R_f.$$

Load voltage:

$$V = E_g - I_a * R_a.$$

The generated power:

$$P_g = E_g * I_a.$$

So, the load delivered power:

$$P_L = V * I_L.$$

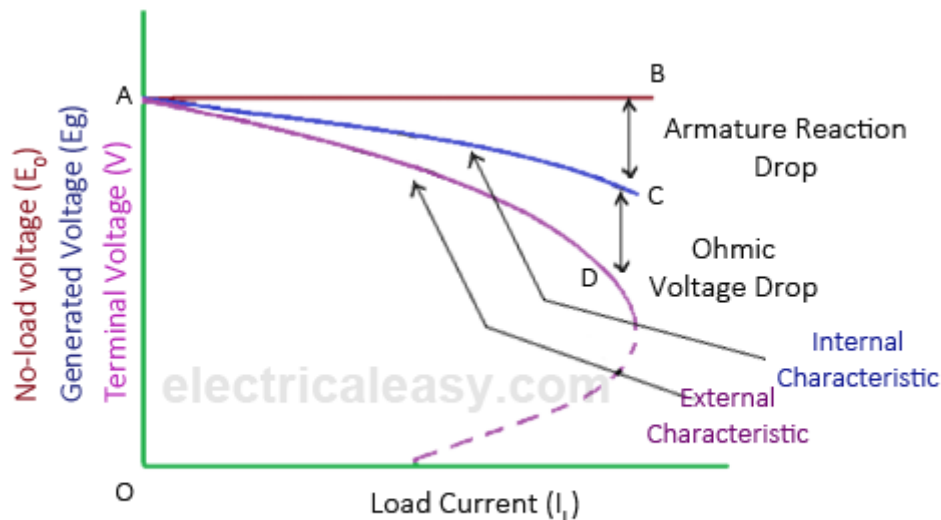

Characteristics of DC shunt generator

To determine the internal and external load characteristics of a DC shunt generator the machine is allowed to build up its voltage before applying any external load. To build up voltage of a shunt generator, the generator is driven at the rated speed by a prime mover. Initial voltage is induced due to residual magnetism in the field poles. The generator builds up its voltage as explained by the O.C.C. curve. When the generator has built up the voltage, it is gradually loaded with resistive load and readings are taken at suitable intervals.

Unlike separately excited DC generator, here, $I_L \neq I_a$. For a shunt generator, $I_a = I_L + I_f$. Hence, the internal characteristic can be easily transmitted to E_g vs. I_L by subtracting the correct value of I_f from I_a .

During a normal running condition, when load resistance is decreased, the load current increases. But, as we go on decreasing the load resistance, terminal voltage also falls. So, load resistance can be decreased up to a certain limit, after which the terminal voltage drastically decreases due to excessive armature reaction at very high armature current and increased I^2R losses. Hence, beyond this limit any further decrease in load resistance results in decreasing load current. Consequently, the external characteristic curve turns back as shown by dotted line in the above figure.