



**Cambridge Assessment
International Education**

Cambridge Lower Secondary Sample Test
For use with curriculum published in
September 2020

Science Paper 2
Mark Scheme
Stage 8

General guidelines on marking

Many descriptive answers can be expressed in a variety of ways. Professional judgement can be used in these cases, providing it matches the marking points and further information in the mark scheme.

Answers may have words spelt incorrectly. Credit is normally given for phonetically correct answers, unless the word has a scientifically different meaning. For example, where the answer should be antennae, credit will be given for antenna but not for anthen (too close to anther).

Only the science is being assessed so answers do not need to be grammatically correct. Significant figures will be indicated in the question or in the mark scheme. Unless specified all marking points are independent.

Annotations and abbreviations

/ OR	alternate responses for the same marking point
() brackets	the words or units in brackets do not need to be stated, for example, (recycles or releases or provides) minerals = minerals scores the mark
<u>Underline</u>	exact word is required
Accept	an acceptable response
Do not accept	indicates an incorrect response that would contradict another otherwise correct alternative
Ignore	indicates an irrelevant answer that is not creditworthy. Full marks can still be achieved even with answers that are ignored.
Note	provides extra information when necessary
ecf	error carried forward; marks are awarded if an incorrect response has been carried forward from earlier working, provided the subsequent working is correct
ora	or reverse argument; for example, as mass increases, volume increases could be written as mass decreases, volume decreases

Question	Answer	Marks	Further Information
1(a)(i)	red (blood cell)/erythrocyte	1	
1(a)(ii)		1	<p>Accept W circled on diagram</p> <p>Accept any indication of the correct answer, e.g. ticking or underlining but circling takes precedence</p>
1(b)	idea of white blood cells fight disease/kill germs	1	<p>Accept fight infection</p> <p>Accept higher level answers, e.g. kill pathogens/ make antibodies</p>
1(c)(i)	plasma	1	Accept serum
1(c)(ii)	(transports) nutrients/ carbon dioxide/ hormones/ urea	1	<p>Ignore blood cells</p> <p>Accept named hormone/ named nutrient/ antibodies</p>
1(d)(i)	10 (mm)	1	<p>Accept to within ± 1 mm</p> <p>Measure the diameter on the printed copy</p>
1(d)(ii)	5.0 (microns)	1	<p>Accept ecf as (d)(i) $\times 0.5$</p> <p>Accept 5</p>

Question	Answer	Marks	Further Information								
2(a)	<table border="1"> <thead> <tr> <th>particle</th> <th>charge</th> </tr> </thead> <tbody> <tr> <td>proton</td> <td>+ / positive</td> </tr> <tr> <td>neutron</td> <td>0 / no charge</td> </tr> <tr> <td>electron</td> <td>- / negative</td> </tr> </tbody> </table>	particle	charge	proton	+ / positive	neutron	0 / no charge	electron	- / negative	2	<p>all three correct = 2 marks</p> <p>one or two correct = 1 mark</p> <p>For proton accept +1 or 1+</p> <p>Do not accept 2+, +3 etc.</p> <p>For electron accept -1 or 1-</p> <p>Do not accept -2, 3- etc.</p>
particle	charge										
proton	+ / positive										
neutron	0 / no charge										
electron	- / negative										
2(b)	nucleus	1									

Question	Answer	Marks	Further Information
3(a)		2	each correct colour = 1 mark
3(b)	blue light no light white light yellow light	1	Accept any indication of the correct answer, e.g. ticking or underlining but circling takes precedence

Question	Answer	Marks	Further Information
4(a)(i)	idea of groups of living organisms interacting with their environment	1	Accept living things and their surrounding Accept an answer that includes an example e.g. the inhabitants of a tropical rain forest
4(a)(ii)	any two from fewer competitors fewer predators abundance of food lots of places to breed more suitable habitats more shelter suitable climate / favourable climate fewer diseases	2	Accept no competitors Accept no predators
4(a)(iii)	may eat all the plants idea / outcompete other species / introduce disease / destroy habitats / affect food chains or food webs	1	Accept eat lots of plants Do not accept eats other animals
4(b)(i)	any one from counting the number of foxes description of suitable sampling technique	1	examples may include setting cameras to sample different area / (humane) traps to sample different areas
4(b)(ii)	idea of an organism that outcompetes a (native) organism	1	Accept species, animal or plant for organism
4(b)(iii)	any one from idea that the map shows a pattern of spread (from the South) across most of Australia foxes are found in areas they were not introduced	1	

Question	Answer	Marks	Further Information
5(a)	(mass) increases	1	
5(b)	105 ± 1 (g)	1	Accept a range of answers provided they are in the given range e.g. 104 – 106
5(c)	69 ± 1 ($^{\circ}\text{C}$)	1	Accept a range of answers provided they are in the given range e.g. 68 – 70

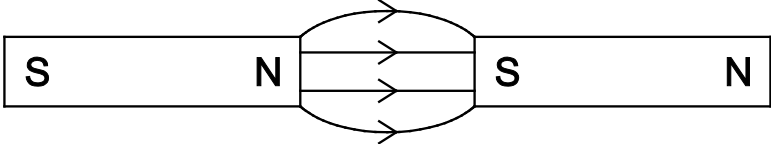
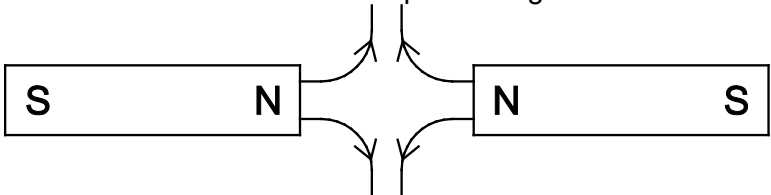
Question	Answer	Marks	Further Information
6a		2	<p>at least two lines going from N to S that do not cross or touch = 1 mark</p> <p>at least one correct arrow not contradicted = 1 mark</p>
6b	<p>at least two lines in the correct pattern e.g.</p> 	1	Ignore direction of arrows if direction is incorrect in (a)

Question	Answer	Marks	Further Information
7(a)	galaxy	1	
7(b)	(stellar) dust / gas	1	Accept moons / asteroids / comets / sub-atomic particles / meteors
7(c)	solar system	1	

Question	Answer	Marks	Further Information
8(a)	magnesium + oxygen → magnesium oxide	1	Accept correct formulae or correct mix of words and formulae but word question takes precedence e.g. $\text{Mg} + \text{O}_2 \rightarrow \text{MgO}$
8(b)	gold is at the bottom of the reactivity series	1	Accept gold is inert
8(c)	calcium hydroxide hydrogen	2	Accept $\text{Ca}(\text{OH})_2$ but name takes precedence Accept H_2/H but name takes precedence

Question	Answer	Marks	Further Information
9(a)	$400 \times 3 = \text{Oliver's weight} \times 2$ or $\text{Oliver's weight} = (400 \times 3) \div 2$ 600 (N)	2	600 (N) on its own = 2 marks
9(b)	pressure = force \div area $\text{Pierre's pressure} = (440 \div 0.04) = 11\,000 \text{ (N/m}^2\text{)}$ $\text{Rajiv's pressure} = (500 \div 0.05) = 10\,000 \text{ (N/m}^2\text{)}$	3	two correct pressure answers = 3 marks Accept correct numerical substitution into equation(s) = 1 mark
Question	Answer	Marks	Further Information
10(a)	C	1	Accept any indication of the correct answer on the diagram but answer line takes precedence
10(b)	core	1	must have the name not the letter
10(c)	compass electromagnet forcemeter voltmeter	1	Accept any indication of the correct answer e.g. underlining or ticking but circling takes precedence

Question	Answer	Marks	Further Information
11(a)	to make it a fair test / to control the variables	1	Ignore references to reliability or accuracy
11(b)	measure the temperature (of the acid) before adding metal measure the temperature of the reaction mixture at the end of the reaction	2	measure temperature at start and end / measure the temperature change = 2 marks Accept measure the temperature = 1 mark if no other mark awarded Ignore other measurements

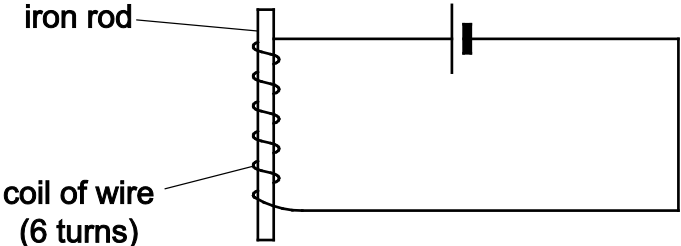
Question	Answer	Marks	Further Information
12	 <p>correct pieces of apparatus selected</p> <p>coil of wire on iron rod</p> <p>circuit correctly drawn</p>	3	labels not needed iron rod, wire and cell = 1 mark Ignore ammeter, voltmeter and switch written or as part of the diagram even if diagram not correct = 1 mark Accept circuit correctly drawn = 3 marks If ammeter, voltmeter and switch shown they must be in the correct place in the circuit

Question	Answer	Marks	Further Information
13(a)	records allow trends and patterns to be observed	1	
13(b)(i)	to increase the validity of the results / to increase the reliability of the results / to enable you to make averages	1	Accept the Earth has a large surface area Ignore reference to accuracy
13(b)(ii)	any one from the changes may be very small (takes a long time) to see a pattern even out any anomalies	1	